

إقرار

أنا الموقع أدناه مقدم الرسالة التي تحمل العنوان:

The influence of street morphology on the thermal performance of buildings in the Gaza Strip

أثر تشكيل الشوارع على الأداء الحراري للمباني في قطاع غزة

أقر بأن ما اشتملت عليه هذه الرسالة إنما هي نتاج جهدي الخاص، باستثناء ما تمت الإشارة إليه حيثما ورد، وإن هذه الرسالة ككل، أو أي جزء منها لم يقدم من قبل لنيل درجة أو لقب علمي أو بحثي لدى أي مؤسسة تعليمية أو بحثية أخرى.

DECLARATION

The work provided in this thesis, unless otherwise referenced, is the researcher's own work, and has not been submitted elsewhere for any other degree or qualification.

Student's name:

اسم الطالب: نضال رسمي إسماعيل أبو مصطفى

Signature:

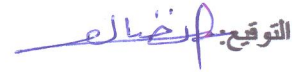
التوقيع: 

Date:

التاريخ: ٢٠١٥/٤/١١ م

The Islamic University Gaza
Deanery of Graduate Studies
Faculty of Engineering
Architecture Department
Master of Architecture Program



The influence of street morphology on the thermal performance of buildings in the Gaza Strip

أثر تشكيل الشوارع على الأداء الحراري للمباني في قطاع غزة

By

Nidal Rasmy Ismail Abu Mostafa

Supervisor

Dr. Ahmed Salama Muhaisen

**“A Thesis Submitted in Partial Fulfillment of the Requirements for the
Degree of Master in Architectural Engineering, Faculty of Engineering,
The Islamic University of Gaza, Gaza– Palestine”**

1435 هـ – 2015 م



نتيجة الحكم على أطروحة ماجستير

بناءً على موافقة شئون البحث العلمي والدراسات العليا بالجامعة الإسلامية بغزة على تشكيل لجنة الحكم على أطروحة الباحثة/ نضال رسمي اسماعيل أبو مصطفى لنيل درجة الماجستير في كلية الهندسة قسم الهندسة المعمارية وموضوعها:

أثر تشكيل الشوارع على الأداء الحراري للمباني في قطاع غزة

The influence of street morphology on the thermal performance of buildings in the Gaza Strip

وبعد المناقشة العلنية التي تمت اليوم السبت 01 جادى الآخر 1436هـ، الموافق 2015/03/21م الساعة الواحدة ظهراً بمبنى اللحيان، اجتمعت لجنة الحكم على الأطروحة والمكونة من:

مشرفاً ورئيساً

د. أحمد سلامة محيسن

مناقشاً داخلياً

د. عمر سعيد عصفور

مناقشاً خارجياً

د. سائد يوسف صالح

وبعد المداولة أوصت اللجنة بمنح الباحثة درجة الماجستير في كلية الهندسة / قسم الهندسة المعمارية.

واللجنة إذ تمنحها هذه الدرجة فإنها توصيها بتقوى الله ولزوم طاعته وأن تسخر علمها في خدمة دينها ووطنها.

والله ولي التوفيق،،،

مساعد نائب الرئيس للبحث العلمي و للدراسات العليا

أ.د. فؤاد علي العاجز



Dedication

This research is lovingly dedicated...

To our respective parents who have been our constant source of inspiration. They have given us the drive and discipline to tackle any task with enthusiasm and determination.

To Palestine, land and human ...

To our martyrs blood ...

To the Islamic University of Gaza ...

To all who helped us ...

We dedicate this modest research and we hope to obtain pride.

Acknowledgement

Thanks and Praise First:

Almighty Allah, who in his great mercy and benevolence has enabled me to undertake and complete this research work.

Thanks:

My supervisor Dr. Ahmed S. Muhaisen for his important and helpful guidance from the beginning to the end of this research.

Thanks:

My committee members; Dr. Saed Y. Saleh and Dr. Omar S. Asfour for their valuable comments and sharing their knowledge.

Thanks:

My grandmother and my parents who have tried to provide us with the appropriate conditions for the completion of this research.

Lastly, We offer our regards and blessings to all of those who supported us in any aspect during the completion of the research.

Abstract

Urban street morphology plays a significant role in the development of a comfortable conditions inside streets canyon and buildings. It directly influences the incident solar radiation falling on streets and façades overlooking it and thus the energy consumption in buildings. The Gaza Strip has suffered from a severe shortage of energy sources as well as from randomness in planning in many areas. Therefore, this research discusses the impact of street morphology on the thermal performance of buildings, especially with regard to the street properties including the aspect ratio i.e. height-to-width ratio H/W and canyon axes orientated, geometric architectural details including galleries, asymmetrical profiles with different openness to the sky and horizontal overhangs on façades, geometric shapes of the street and the main element of streets which is vegetation. Also the research provides an overview of the situation in the Gaza Strip focusing on streets design especially with regard to their geometries and orientation.

The research assumes that the configuration of streets has a great impact on the viability of passive solar heating and cooling in the building and thus reducing the energy consumption. Hence, the research highlights the configuration of an urban street in the Gaza Strip in an attempt to find solutions for improving the environmental planning for the street. This research aims to discuss factors that affect the thermal balance of the building in accordance with local environmental conditions of the Gaza Strip. In order to achieve the purpose of the research, thermal simulation software ECOTECT and International Development Association - Indoor Climate and Energy (IDA-ICE) were utilized to assess the effect of street morphology on the incident solar radiation and the thermal performance of buildings in the Gaza Strip. The results indicate important thermal effects as a result of the street properties and architectural design details.

The study concluded that the thermal stress can affectively be mitigated if galleries, overhanging facades or asymmetrical canyons are appropriately combined with the aspect ratio and solar orientation. Contrasting situations in the comfort conditions are found between shallow and deep urban streets as well as between the various orientations studied. It was concluded that the narrow canyons with aspect ratio (H/W) of 4.0 provides the maximum energy savings in summer. About 37.25% of energy consumption can be reduced by choosing the optimum orientation, which is E-W. Asymmetrical profiles seemed to have a significant influence on the thermal response. The ratio of the opposite buildings heights (building 2 height H_2 /building 1 height H_1) which ranges between 1.2 to 2.0 is more preferable for both cooling and heating requirements. The optimum overhanging facades width is 2.0m. It is noted that the gradual overhanging facades are more suitable for energy efficiency than the regular overhanging facades. Moreover, buildings facing west in (N-S) plover street has a better behavior. Therefore, the research recommends to pay more attention to the streets design especially with regard to their widths, orientations and shapes for the purpose of energy saving and thermal comfort.

الملخص

يلعب تشكيل الشارع الحضري دورا هاما في توفير ظروف مريحة داخل الشوارع والمباني، إنه يؤثر مباشرة على الإشعاع الشمسي الساقط على الشوارع وكذلك الواجهات المطلة عليه، وبالتالي على استهلاك الطاقة في المباني. عانى قطاع غزة من نقص حاد في مصادر الطاقة وكذلك من عشوائية في التخطيط في العديد من المناطق. لذلك، يناقش هذا البحث تأثير تشكيل الشارع على الأداء الحراري للمباني، خاصة فيما يتعلق بخصائص الشارع التي تتضمن نسبة ارتفاع المبنى إلى عرض الشارع أي نسبة H / W و توجيه محور الشارع، والتفاصيل المعمارية الهندسية التي تتضمن المظلات والارتفاعات غير المتكافئة مع الانفتاح المختلف نحو السماء والواجهات الأفقية المرتدة للأمام (الطائر)، كذلك الشكل الهندسي للشارع والعنصر الرئيسي في الشوارع وهو الغطاء النباتي. كما يقدم البحث لمحة عامة عن الوضع في قطاع غزة مع التركيز على تصميم الشوارع خاصة فيما يتعلق بهندستها وتوجيهها.

ويقترض البحث أن تشكيل الشوارع له تأثير كبير على جدوى التبريد والتدفئة الشمسية السلبية في المبنى، وبالتالي تقليل استهلاك الطاقة. من هنا ركز البحث على تشكيل شوارع المدن في قطاع غزة في محاولة لإيجاد حلول لتحسين التخطيط البيئي للشارع. يهدف هذا البحث إلى مناقشة العوامل التي تؤثر على التوازن الحراري للمبنى وفقا للظروف البيئية المحلية لقطاع غزة. من أجل تحقيق الغرض من البحث، تم استخدام برامج المحاكاة الحرارية ECOTECT و IDA ICE لتقييم تأثير تشكل الشارع على الإشعاع الشمسي والأداء الحراري للمباني في غزة قطاع. تشير النتائج إلى التأثيرات الحرارية المهمة نتيجة لخصائص الشارع وتفاصيل التصميم المعماري.

خلصت الدراسة إلى أنه يمكن تخفيف الإجهاد الحراري بشكل فعال إذا تم الدمج المناسب بين المظلات أو الواجهات المرتدة للأمام (الطائر) أو الأخاديد غير المتكافئة مع نسبة ارتفاع المبنى إلى عرض الشارع والتوجيه. لقد وجدت حالات متناقضة في ظروف الراحة بين الشوارع الضحلة والعميقة وكذلك بين مختلف التوجيهات المدروسة. وقد خلصت الدراسة إلى أن الأخاديد الضيقة مع نسبة $(H / W) = 4,0$ توفر الطاقة خاصة في الصيف، يمكن تخفيض استهلاك الطاقة بنسبة ٣٧,٢٥٪ عن طريق اختيار التوجيه الأمثل وهو توجيه شرق غرب. الأخاديد غير المتكافئة يكون لها تأثير كبير على الاستجابة الحرارية، نسبة ارتفاعات المباني المتقابلة (ارتفاع مبنى ٢ / ارتفاع مبنى ١) التي تتراوح بين ٢,١-٢,٠ هي الأفضل لكل من متطلبات التبريد والتدفئة. العرض الأمثل للواجهات (الطائر) هو ٢,٠م، لوحظ أن الواجهات التدريجية (الطائر) أفضل من الواجهات المنتظمة بالنسبة لكفاءة الطاقة. علاوة على ذلك، المباني التي تواجه الغرب في الشارع المتعرج الموجه شمال جنوب توفر أفضل سلوك حراري. لذا، يوصي البحث بإيلاء المزيد من الاهتمام لتصميم الشوارع خاصة فيما يتعلق بعروضها، توجيهاتها وأشكالها من أجل توفير الطاقة والراحة الحرارية.

List of Contents

Dedication	I
Acknowledgement.....	II
Abstract	III
المخلص	IV
List of Contents	V
List of Tables.....	VIII
List of Figures	IX
List of Abbreviations.....	XV
Chapter 1: General Introduction.....	1
1.1 Introduction	1
1.2 Research Problem.....	3
1.3 Research Hypothesis	3
1.4 Importance of the Research	4
1.5 Objectives of the Research	4
1.6 Methodology	5
1.7 Research Limits.....	6
1.8 Structure of the Research	7
1.9 Previous Studies	7
1.10 Conclusion.....	11
Chapter 2: Energy Efficiency of Urban Design	12
2.1 Introduction	12
2.2 Energy efficiency and renewable energy.	12
2.2.1 Environmental effects of energy use	13
2.2.2 Energy efficiency	13
2.2.3 The benefits of energy efficiency	14
2.2.4 Renewable energy	14
2.2.5 Cross cutting issues for energy efficiency and renewable energy.....	15
2.3 Energy- efficient urban design	15
2.3.1 Definition of urban design.....	16
2.3.3 Principles of energy efficiency for urban design.....	16
2.3.4 Strategies of energy efficient urban design	16
2.3.4.1 Site selection and orientation	17
2.3.4.2 Density	18
2.3.4.3 Climate optimisation	20
2.3.4.4 Buildings Envelope	25

2.3.4.5 Transport	26
2.3.5 Urban design and comfort outdoors	26
2.3.5.1 Outdoor thermal comfort.....	27
2.3.5.2 Effects of urban design on comfort outdoors	28
2.4 Thermal performance of buildings.....	29
2.4.1 Definition of Thermal Performance	29
2.4.2 Assessing thermal performance.....	29
2.4.3 Impact of Thermal Performance on Energy Consumption.....	30
2.4.4 Heat balance	30
2.4.5 Determinants of thermal comfort	31
2.4.6 Factors Affecting Thermal Performance of Buildings	33
2.5 Conclusion.....	38
Chapter 3: Streets Design and the Situation in the Gaza Strip	39
3.1 Introduction	39
3.2 Definition and components of street	39
3.2.1 Street definition	39
3.2.2 Urban morphology	40
2.2.3 Principal functions of streets	40
3.2.4 The major components of street design.....	40
3.2.4.1 Width of the street.....	40
3.2.4.2 Pattern of the street network.....	41
3.2.4.3 Physical elements along the streetscape.....	44
3.2.4.4 A four level road hierarchy	46
3.3 Thermal comfort of street.....	47
3.3.1 Street design conditions.....	47
3.3.2 Factors affecting thermal comfort in urban street canyons	47
3.4 Energy, climate, streets and buildings situation in Gaza Strip.....	53
3.4.1 The Gaza Strip in brief	53
3.4.2 Energy situation in the Gaza Strip.....	54
3.4.2.1 Energy shortage in the Gaza Strip.....	54
3.4.2.2 Residential building and energy use.....	56
3.4.2.3 Renewable energy potential in the Gaza Strip	56
3.4.3 Climate conditions in the Gaza Strip.....	58
3.4.4 Streets situation in the Gaza Strip	59
3.4.5 Residential buildings in the Gaza Strip	70
3.5 Conclusion.....	71
Chapter 4: The effect of streets morphology on the incident solar radiation	73
4.1 Introduction	73

4.2 Study Parameters.....	73
4.2.1 Simulation Tools and Validity.....	74
4.2.1.1 IDA Indoor Climate and Energy (IDA ICE)	74
4.2.1.2 ECOTECT	75
4.2.2 Climatic Parameters	75
4.2.3 Building Parameters	76
4.2.4 Urban Street Geometry.....	77
4.2.4.1 Parametric Investigation.....	77
4.2.4.2 Discussion of results.....	83
4.3 Conclusion.....	101
Chapter 5: The Effect of Streets Morphology on the Thermal Performance of Buildings	103
5.1 Introduction	103
5.2 Urban Street Geometry.....	104
5.2.1 Parametric Investigation.....	104
5.2.2 Discussion of results.....	108
1. Effect of Aspect Ratio (H/W).....	108
2. Effect of Street Orientation	111
3. Effect of Galleries	114
4. Effects of the canyon Asymmetry	118
5. Effects of the overhanging facades	121
6. Geometric shape of the street	126
5.3 Conclusion.....	128
Chapter 6: Conclusion and Recommendations	129
6.1 Introduction	129
6.2 Conclusions	129
6.2.1 Energy- efficient urban design	129
6.2.2 The situation in the Gaza strip.....	131
6.2.3The impact of streets design on the overall energy demand.....	131
6.3 Recommendations	135
6.5 Suggestions for further studies	137
References	138
Appindex1	149

List of Tables

Table (2.1): Limiting obstruction angle h to ensure at least 3 hours sun in specified period	18
Table (2.2): The relationship between incident solar radiation angel and solar radiation percentage.....	22
Table (3.1): Street properties at the twenty six different points in the Gaza city	65
Table (3.2): Zoning district regulations in the Gaza Strip.....	70
Table (4.1): The urban canyon parameters investigated in the study	78
Table (4.2): Trees numbers and locations parameters investigated in the study	82
Table (5.1): The urban canyon parameters investigated in the study	104
Table (5.2): The three options investigated in the study.....	127

List of Figures

Figure (2.1): Long-term energy savings from improvements in energy efficiency, OECD.	14
Figure (2.2): Passive solar site layouts with main solar collecting facades of houses facing within 30 degrees of due south can achieve space heating savings of over 10% compared to conventional layouts.....	17
Figure (2.3): For solar access the area of sky between SE and SW becomes important. ...	18
Figure (2.4): reducing site coverage to allow more open space at grade	19
Figure (2.5): Solar altitude and azimuth.....	21
Figure (2.6): Radiation balance in the atmosphere	23
Figure (2.7): sky view factor (SVF) of an urban street canyon	23
Figure (2.8): Urban air flow depends on Building Height/Street Width (H/W) ratio	24
Figure (2.9): Prevailing wind direction enhance air movements	24
Figure (2.10): L: Temporal variations of air temperature in an urban area and its rural surroundings, R: Perspectives shows an urban and rural areas.....	25
Figure (2.11): Buildings should be designed to encourage natural ventilation	26
Figure (2.12): A person exposed to direct (I), diffuse (D) and reflected (R) short-wave radiation as well as long-wave radiation from the sky and the urban surfaces	27
Figure (2.13): Mechanisms of heat loss from the human body and relative magnitudes for a resting person.	31
Figure (2.14): Olgyay's Bioclimatic Chart	33
Figure (2.15): Givoni's Bioclimatic Chart.....	33
Figure (2.16): Different shapes of building	34
Figure (2.17): The best orientation of the building to solar radiation and wind	35
Figure (2.18): The three common approaches to passive ventilation	37
Figure (3.1): Different widths for streets.....	41
Figure (3.2): L: Example of a rectilinear grid pattern with residential streets, boulevards and parks, R: Example of diamond grid pattern that provides interconnections and responds to steep terrain.	42
Figure (3.3): L: Example of picturesque landscape pattern following the terrain and preserving environmentally sensitive areas, R: Example of a rural village pattern showing loosely organized interconnections.....	42
Figure (3.4): L: Example of the curvilinear grid pattern that runs mostly parallel to topography, R: Example of spiderweb pattern that radiates from a center or monument...	43
Figure (3.5): Example of the stem pattern of cul-de-sacs, collectors, and arterials.	43
Figure (3.6): L: Cross section of sidewalk, R: Conceptual plan: sidewalk.....	44
Figure (3.7): Street corners.....	44
Figure (3.8): The elements of streetscape.....	45
Figure (3.9): A four level road hierarchy for network planning and management.	46
Figure (3.10): Scheme of the urban canyon geometries and the various orientations	48

Figure (3.11): (a) Wind flow regimes and (b) corresponding threshold lines dividing flow into three regimes as function of canyon (H/W) and building (L/W) geometry	49
Figure (3.12): Scheme of the gallery	50
Figure (3.13): an asymmetrical urban canyon with a wide opening to the sky	51
Figure (3.14): an asymmetrical urban canyon with overhanging facades and galleries	52
Figure (3.15): Gaza Strip map	54
Figure (3.16): Power Deficit – Gaza Strip.....	55
Figure (3.17): The Percentage Imports of energy's derivatives by Sectors in 2005.....	56
Figure (3.18): The annual variation in solar radiation (MJ/m ² /day) in Gaza Strip Source: Source: Ministry of local government, 2004	58
Figure (3.19): The annual average wind speed (m/s) in Gaza Strip	59
Figure (3.20): The annual average Relative Humidity in Gaza Strip	59
Figure (3.21): streets and parcel's orientation in the Gaza strip	60
Figure (3.22): Plan for Gaza City shows the streets names.....	62
Figure (3.23): a: plan for Al-Daraj area	63
Figure (3.24): Route and all selected points within different street geometries in Gaza City	64
Figure (3.25): Photographs of selected sites within the Gaza city	69
Figure (4.1): Simulation tab in IDA Indoor Climate and Energy (IDA ICE) program	74
Figure (4.2): Some applications of ECOTECH program	75
Figure (4.3): a: The sun path in summer and winter period and its relation with the building facades in East – West street orientation, b: in North – South street orientation.....	77
Figure (4.4): The concept of aspect ratio parameter (H/W)	77
Figure (4.5): The seven values of street's orientation considered in the study	79
Figure (4.6): The concept of gallery parameter.....	79
Figure (4.7): a: Seven values of gallery width to street width ratio simulated in the study, b: Eight values of gallery height to building height ratio considered.....	80
Figure (4.8): The concept of Asymmetrical urban canyon parameter	80
Figure (4.9): Nine values of building (2) height to building (1) height ratio (H ₂ /H ₁)	80
Figure (4.10): The concept of overhanging facades parameter.....	81
Figure (4.11): Eight values of sky opening width to street width ratio considered in the study	81
Figure (4.12): The three main geometric shape of streets simulated in the study	82
Figure (4.13): a: Incident solar radiation on the wall facing east and (N-S) street in the hottest month, b: in the coldest month by ECOTECH.....	83

Figure (4.14): a: Incident solar radiation on the wall facing east in the hottest month, b: in the coldest month by IDA ICE.....	84
Figure (4.15): a: Percentage of increasing in incident solar radiation on façade overlooking the street in summer, b: in winter by ECOTEECT.....	84
Figure (4.16): a: Incident solar radiation on façades overlooking street in the hottest month, b: in the coldest month by ECOTEECT.	85
Figure (4.17): a: Percentage of increasing in incident solar radiation on façades overlooking street in the hottest month, b: Percentage of reduction in the coldest month by ECOTEECT.	86
Figure (4.18): a: Incident solar radiation on the wall facing south perverted toward east in the hottest month, b: on the wall facing north perverted toward west by ECOTEECT.	87
Figure (4.19): a: Incident solar radiation on the wall facing south perverted toward east in the coldest month, b: on the wall facing north perverted toward west by ECOTEECT.	87
Figure (4.20): a: Incident solar radiation on the streets in the hottest month, b: in the coldest month by ECOTEECT.....	88
Figure (4.21): a: Percentage of reduction in incident solar radiation on façades overlooking (N-S) and (E-W) street as a result of differences in galleries width in the hottest month, b: in the coldest month by ECOTEECT.....	89
Figure (4.22): a: Percentage of reduction in incident solar radiation on façades overlooking (N-S) and (E-W) street as a result of differences in galleries width in the hottest month, b: in the coldest month by IDA ICE.....	89
Figure (4.23): a: Percentage of reduction in incident solar radiation on façades overlooking (N-S) and (E-W) street as a result of differences in galleries height in the hottest month, b: in the coldest month by ECOTEECT.....	91
Figure (4.24): a: Percentage of reduction in incident solar radiation on (E-W) street as a result of differences in galleries width, b: as a result of differences in galleries height by ECOTEECT.	92
Figure (4.25): a: Percentage of increasing and reduction in incident solar radiation on façades overlooking (N-S) and (E-W) street as a result of canyon asymmetry in the hottest month, b: in the coldest month by ECOTEECT.	93

Figure (4.26): a: Percentage of increasing and reduction in incident solar radiation on (N-S) and (E-W) streets as a result of canyon asymmetry in the hottest month, b: in the coldest month by ECOTECT.....	94
Figure (4.27): a: Percentage of reduction in incident solar radiation on façades overlooking (N-S) and (E-W) street as a result of differences in overhanging facades width in the hottest month, b: in the coldest month by ECOTECT.....	95
Figure (4.28): a: Percentage of reduction in incident solar radiation on façades overlooking (N-S) and (E-W) street as a result of differences in overhanging facades width in the hottest month, b: in the coldest month by IDA.....	96
Figure (4.29): a: Percentage of reduction in incident solar radiation on (E-W) street as a result of overhanging facades design in the hottest month, b: in the coldest month.	97
Figure (4.30): a: Percentage of reduction in incident solar radiation on façades overlooking (N-S) street as a result of streets planting in the hottest month, b: in the coldest month. ...	98
Figure (4.31): a: Percentage of reduction in incident solar radiation on façades overlooking (E-W) street as a result of streets planting in the hottest month, b: in the coldest month. ..	99
Figure (4.32): a: Percentage of reduction in incident solar radiation on (E-W) street as a result of streets planting in the hottest month, b: in the coldest month.	99
Figure (4.33): a: Incident solar radiation on façades overlooking different shapes of streets in the hottest month, b: in the coldest month.	100
Figure (4.34): a: Incident solar radiation on different shapes of streets in the hottest month, b: in the coldest month.....	101
Figure (5.1): The seven values of street's orientation considered in the study	105
Figure (5.2): a: Four values of gallery width simulated in the study, b: Five values of gallery height considered	106
Figure (5.3): Five values of building (2) height simulated in the study.	106
Figure (5.4): a: Four values of overhanging facades width considered in the study, b: gradual overhanging facades (0.5m for each floor)	107
Figure (5.5): The three main geometric shape of streets simulated in the study	107
Figure (5.6): a: Cooling loads in north-south oriented street axis by IDA ICE, b: Heating loads.....	108
Figure (5.7): a: Total loads in (N-S) oriented street axis by IDA ICE.	109

Figure (5.8): a: Cooling Loads in the ground, middle and upper floor in (N-S) street by IDA ICE, b: Heating loads	110
Figure (5.9): Total Loads in the ground, middle and upper floor in (N-S) street	111
Figure (5.10): a: Cooling loads for H/W= 4 for the two buildings overlooking various orientations by IDA ICE, b: Heating loads.....	112
Figure (5.11): a: Cooling Loads in the ground, middle and upper floor in the building facing north in (E-W) street by IDA ICE, b: Heating loads	112
Figure (5.12): A four apartments orientation	113
Figure (5.13): a: Cooling Loads in four apartments orientation in the building facing north in (E-W) street by IDA ICE, b: Heating loads.	114
Figure (5.14): a: Total loads in four apartments orientation in the building facing north in (E-W) street	114
Figure (5.15): a: Percentage of reduction in the cooling loads in the building facing west in (N-S) street and the building facing north in (E-W) street as a result of differences in galleries width, b: Percentage of increasing in the heating loads.....	115
Figure (5.16): a: Percentage of reduction in the total loads as a result of differences in galleries width by IDA ICE.....	116
Figure (5.17): a: Percentage of reduction in the cooling loads in the building facing west in (N-S) street as a result of differences in galleries height, b: Percentage of in increasing the heating loads	117
Figure (5.18): a: Percentage of reduction in the cooling loads in the building facing north in (E-W) street as a result of differences in galleries height by IDA ICE, b: Percentage of increasing in the heating loads.....	118
Figure (5.19): a: Percentage of reduction in the cooling loads in the building facing west in (N-S) street as a result of canyon asymmetry by IDA ICE, b: Percentage of in increasing the heating loads	119
Figure (5.20): a: Percentage of reduction in the total loads in the building facing west in (N-S) street as a result of canyon asymmetry by IDA ICE	120
Figure (5.21): a: Percentage of reduction in the cooling loads in the building facing north in (E-W) street as a result of canyon asymmetry by IDA ICE, b: Percentage of increasing in the heating loads	121

Figure (5.22): a: Percentage of reduction in the cooling loads in the building facing west in (N-S) street as a result of regular overhanging facades by IDA ICE, b: Percentage of increasing the heating loads 122

Figure (5.23): a: Percentage of reduction in the total loads in the building facing west in (N-S) street as a result of regular overhanging facades by IDA ICE..... 122

Figure (5.24): a: Percentage of reduction in the cooling loads in the building facing north in (E-W) street as a result of regular overhanging facades by IDA ICE, b: Percentage of increasing in the heating loads..... 123

Figure (5.25): a: Percentage of reduction in the cooling loads in the building facing west in (N-S) street as a result of gradual overhanging facades, b: Percentage of increasing the heating loads. 124

Figure (5.26): a: Percentage of reduction in the cooling loads in the building facing north in (E-W) street as a result of gradual overhanging facades by IDA ICE, b: Percentage of increasing in the heating loads..... 125

Figure (5.27): a: Percentage of reduction in the total loads in the building facing north in (E-W) street as a result of gradual overhanging facades by IDA ICE. 125

Figure (5.28): a: Percentage of reduction in the total loads in the building facing north in (E-W) street as a result of varying the geometric shape of the street..... 126

List of Abbreviations

Abbreviations	Meaning
ARIJ	Applied Research Institute in Jerusalem
CO ₂	Carbon Dioxide
E.E.	Energy Efficiency
FAR	Floor Area Ratio
GHG	Greenhouse Gas
h/H	The ratio between the gallery height to the building height
H/W	Aspect Ratio which is the ratio between the building height H to the width of the street W
(H ₂ /H ₁)	Heights of buildings ratio which is the ratio between building (2) height to building (1) height in asymmetric streets.
HVAC	Heating, Ventilation, and Air Conditioning
IDA-ICE	International Development Association - Indoor Climate and Energy program
L	Left figure
MRT	Mean radiant temperature
MWh	Megawatt Hour
OECD	Organisation for Economic Co-operation and Development
PCBS	Palestinian Central Bureau of Statistics
PET	Physiologically equivalent temperature
PMV	Predicted Mean Vote
PV	Photovoltaics
R	Right figure
R.E.	Renewable Energy
SVF	Sky view factor
T _a	Air temperature
U value	Thermal Transmittance
w/W	The ratio between the gallery width to the street width
w'/W	The ratio between the overhanging facades width to the street width
WWR	Window to Walls Ratio

Chapter 1: General Introduction

1.1 Introduction

Study a climatic factors affecting streets and building design are a shared field to climatologists and designers. It is noticed through previous studies that the integration of the climate dimension in the design process is lacking as a consequence of poor teamwork. For this reason, they emphasize the necessity of formation suitable base on applicable design guidelines to promote more collaboration between both fields and overcome this deficit (Toudert, 2005). For example, solar radiation falling on urban areas has a great impact on outdoor comfort as well as on buildings' energy consumption. Unplanned rapid urban growth in world cities especially hot dry regions leads to large environmental consequences and changes in urban climate such as temperature differences, which is affected by changes in urban form where street configuration is considered the main responsible for urban design (Krüger et al., 2010). It is worth noting that the street seems as the interface of urban and architectural design where it consists of shared aspects between the building envelope and the open spaces, i.e. the street configuration affects the thermal sensation of pedestrian as well as the energy consumption of buildings. Accordingly, a climate should be one of the most significant planning standards in order to obtain the design of an urban street, which can effectively promote thermal comfort in the buildings.

The energy is essential to improve quality of life in all countries. Nowadays, it is noted that energy consumption of non-renewable fossil fuels has increased. This using of fossil sources to produce energy causes several environmental effects such as global warming, ozone depletion and acid rain as well as adverse impacts on the human health. Moreover, these traditional types of energy are expected to run out. Passive solar design involves appropriate street morphology can increase the benefits of ambient energy for heating, lighting and ventilation and reduce the consumption of conventional fuels. Street configuration with various canyons, axis orientations and geometric shapes have an impact both on outdoor and on indoor conditions, i.e. the potential for passive solar gains inside and outside the buildings as well as the urban absorption versus reflectance of radiation (Papadopoulos, 2001). Streetscape needs to meet environmental efficiency to achieve sustainable streets, that can provide thermal comfort in the street and buildings (Rehan,

2013). Thus, appropriate streets morphology can provide compliance environment for low energy strategies.

The Gaza Strip disregards the hierarchy in the streets. Streets in the Gaza Strip has different shapes, canyons and orientations. That is due to the different models of planning from one area to another in the Gaza Strip. For example, there is the grid system where straight street perpendicular to each other. Also, there is an annular model (radial) where buildings regulated around a ring road. There is also a branches model, where closed local streets branching out from collector street like a tree. Random planning phenomenon resulted in indiscriminate ratios between buildings height and street width which are not usually determined in accordance with the standards of energy-saving in buildings (El-Kahlout, n.d.). This situation can contribute in increasing the discomfort period inside streets canyons and buildings. In addition, street design in the Gaza Strip doesn't take enough account to the assessment of urban climatic factors such as solar radiation and wind, which directly influence the amount of solar radiation within the streets as well as the thermal performance in buildings. On the other hand, the Gaza Strip suffers from a serious problem in energy, a lack of fossil fuels and cut of electricity supply for several years as a result of the occupation procedures (Muhaisen, 2007). Thus, alternative ways which use more renewable sources must be utilized to reduce the energy problems.

The thesis aims to highlight the thermal situation in the Gaza Strip with special emphasis on the street morphology including street properties, shapes and geometric architectural details. This study seeks to contribute towards a deeper understanding of the influence of architectural street design on the incident solar radiation and the thermal performance of buildings. On the other hand, the focus is put on the applicability of the results, i.e. expressed in form of design guidelines in the Gaza Strip. General streets configurations taking into consideration aspect ratio (H/W), street axis orientations and different shading elements such as galleries, horizontal overhangs on façades and vegetation will be simulated. The analytical approach using computer simulation tools namely "ECOTECT and International Development Association - Indoor Climate and Energy (IDAICE)" were utilized to carry out the study.

1.2 Research Problem

"Gaza Strip suffers from several planning problems both in its urban and rural areas, particularly as regards roads and infrastructure. The planning problems are manifest in a several phenomen, most notably the random construction, heterogeneity in models of road networks, twisted and closed roads, limited roads widths and land fragmentation" (El-Kahlout, n.d., 1).

Gaza strip has suffered from randomness in planning in many areas, particularly street configuration, which is the main ingredient in urban planning. Street configuration in the Gaza Strip varies in geometry, shape and orientation due to the different models of planning such as the grid system as in the northwestern areas of Gaza City (new Gaza), and an annular model as in the old town in the center of Gaza City as well as in KhanYounis city and a branches model as in the old town of the Gaza city, east of Gaza's cities and unorganized regions. These various forms of planning usually are not determined in accordance with the environmental and climatic factors. This affects negatively the thermal performance of buildings and increases the energy demand.

In addition, there is a clear lack in electricity supply to the Gaza Strip, which is directly related to the increasing consumption of fossil fuels. This situation needs development of rules for energy- efficient urban design through planning and design of streets.

1.3 Research Hypothesis

The research assumes that interdisciplinary work which combines design and climate has a significant impact on the thermal comfort within streets and building in the Gaza Strip, i.e. the configuration of streets including street geometry, orientation and shape, which take into account the environmental factors, have a positively impact on the incident solar radiation and the thermal performance of buildings. It assumes that further shading through geometric architectural details including galleries, asymmetrical profiles and overhanging façades able to decrease the area of thermal discomfort within streets and to modify the impact of the sun load and thus the total thermal loads of the buildings. Therefore, it is expected that appropriately good climatic planning rules combined, all investigated proper design principles can affectively mitigate heat stress and promote thermal comfort.

1.4 Importance of the Research

This study is one of studies that are gaining an unprecedented focus and attention. It investigates the street configuration in the Gaza Strip which plays a significant role in determining the amount of solar radiation falling on streets and building facades overlooking it and thus affecting the thermal performance of buildings. The research highlights urban street design in the Gaza Strip in an attempt to find out solutions for improving the street environmental planning, enhance the comfort conditions and rationalizing the energy consumption of buildings. On the other hand, the thesis encourages decision-makers to study the other design principles of energy efficient buildings in the Gaza Strip. The study will use various simulation tools to help in estimating thermal comfort in relatively accurate and reasonable results.

1.5 Objectives of the Research

This research is primarily motivated by the will to investigate the impact of street configuration including street geometrical shape, axis orientation and geometric architectural details on the thermal performance with regard to solar radiation and energy consumption. In this research the following objectives are highlighted:

- 1- Identify the strategies of energy efficient urban design, which include site selection and orientation, density, climate optimisation and buildings to illustrate the effect of these strategies on thermal comfort of indoor environment.
- 2- Study the factors affecting thermal comfort in urban street canyons as well as buildings.
- 3- Study the current situation of energy, climate, streets and buildings in the Gaza Strip.
- 4- Examine the effects of the street properties including the aspect ratio H/W and canyon axes orientated and geometric shapes of the street on thermal performance of buildings.
- 5- Investigate the effects of various design details including galleries, asymmetry of the street profile, horizontal overhangs and vegetation on thermal performance of buildings.
- 6- Quantify the contribution of proper streets design in mitigating the heat stress.
- 7- Choose the optimal street design according to the analysis results.

1.6 Methodology

Quantitative and qualitative approaches will be adapted including the following aspects:

1- Data-related Literature

Related publications were reviewed in order to look into successful experiences that were conducted by other countries in analyzing the effect of street design on thermal comfort within streets and energy efficiency in buildings. A summarized literature review on energy efficiency of urban design and the thermal performance in streets canyons and buildings are carried out as theoretical background. It depends on theoretical sources for the scientific information such as researches, conference papers, previous studies and statistics from governmental institutions.

2- Studying the current situation in the Gaza Strip.

Study and analyze the situation of energy, climate, streets and buildings in the Gaza Strip to understand the impact of streets morphology on the energy efficiency in buildings.

3- Parametric study:

This research is mainly carried out by using a parametric analytic approach depending mainly on thermal simulation tools, namely ECOTECH and IDA Indoor Climate and Energy (ICE) which provide quantitative results, so that a series of geometries combined with various street orientations and other arrangements could be analyzed and compared.

ECOTECH - amongst other design tools- is a software package with a unique approach for conceptual building design coupling an intuitive 3D design interface with a comprehensive set of environmental performance analysis functions and interactive information displays. ECOTECH provides its own fast and intuitive modelling interface for generating even the most complex building geometry (Marsh, 2003). ECOTECH Analysis offers a wide range of simulation and building energy analysis functionality that can improve performance of existing buildings and new building designs. Online energy, water, and carbon-emission analysis capabilities integrate with tools that enable to visualize and simulate a building's performance within the context of its environment. In addition, it visualize incident solar radiation on windows and surfaces over any period. It displays the sun's position and path relative to the model at any date (Autodesk Ecotect Analysis, 2012). Also, ECOTECH allows user to automatically shape shading devices

given specific performance parameters or even interactively spraying acoustic rays to accurately position reflectors (Marsh, 2003).

(IDA Indoor Climate and Energy, developed by EQUA, Sweden) was employed in order to evaluate the effect of different street canyon geometries and orientations on building heating and cooling loads in the Mediterranean climate of the Gaza Strip. In addition, it was used as a validation tool. (IDA ICE) is a program for study of the indoor climate of individual zones within a building, as well as energy consumption for the entire building. It covers a range of advanced phenomena such as integrated airflow and thermal models, CO₂ modeling, and vertical temperature gradients. The user interface is divided into three different levels, with different support and scope for the user: the simplest level, called wizard, the standard and the advanced levels. The application can be used for most building types for calculation of, among others: full zone heat balance, directed operating temperature for estimation of asymmetric comfort conditions, comfort indices, daylight level at an arbitrary room location. It is primarily intended for HVAC designers and architects, but is also appreciated by educators and researchers (EQUA Simulation AB, 2013a; EQUA Simulation AB, 2013b).

1.7 Research Limits

The research focuses on the influence of street configuration on solar radiation in the Gaza Strip, which extends along the eastern Mediterranean Sea specifically on longitude 34° 26' east and latitude 31° 10' north (Ministry of local government, 2004). The study depends on the simulation programs which are ECOTECT and IDA Indoor Climate and Energy. The following design parameters in the street configurations will be analyzed:

- street properties including
 - a) Height-to-width ratio (aspect ratio H/W).
 - b) Canyon axes orientated, i.e. 0E (E-W), 10E, 20E, 30E, 40E, 50E, 60E, 70E, 80E, and 90E (N-S).
- Geometric architectural details including
 - a) Galleries as a shading device.
 - b) Asymmetrical vertical profiles.
 - c) Overhanging façades with small opening to the sky.
- Geometric shapes of the street, i.e. straight, curved and plover.
- Landscaping and building form were not taken into account.

1.8 Structure of the Research

The study is structured into two parts. First part is the literature review, which focuses on the concept of energy- efficient streets design, the thermal performance of buildings and the situation in the Gaza strip. The second part includes parametrical study to examine the impact of streets morphology on the overall energy consumption. So that the thesis is structured into six chapters as follows:

Chapter 1 is a general introduction including the research background, problem, hypothesis, importance, objectives, methodology, limits and an overview of previous studies that dealt with similar subjects.

Chapter 2 presents a literature review about energy efficiency and renewable energy with special focus on energy- efficient urban design explaining its principles and strategies. In addition, this chapter describes the concepts of thermal performance of buildings.

Chapter 3 introduces a literature review about the definition and components of street and presents the main factors affecting thermal comfort in urban street canyons. Also, it describes energy, climate, streets and buildings situation in the Gaza strip.

Chapter 4 investigates the impact of streets morphology on the incident solar radiation falling on streets and building facades overlooking it through four parts: first part describes the simulation tools and validity, second part discusses climatic parameters, third part describes the building parameters, last part discusses urban street geometry parameters and the study results.

Chapter 5 investigates the impact of streets morphology on the overall energy performance of buildings.

Chapter 6 presents the summarization of the conclusions along with recommendations derived from the gathered data and the simulation which is discussed in this study.

1.9 Previous Studies

1. Papadopoulos, A. (2001). The influence of street canyons on the cooling loads of buildings and the performance of air conditioning system.

This paper outlines a computational approach to the street canyon phenomenon, with the determination of flow and temperature field which are developed and discusses their influence on the dynamic thermal balance of the building. Two basic software tools were

used for the computational solution of the phenomenon: the CFX-TASC flow and the SUNCODE PC. The ultimate goal of the study of this phenomenon needs to be the development of rules for urban planning, design of building and construction, which will ensure rational energy management and conservation. The simulation of the air temperature and flow fields in the canyon showed that, when the air conditioning is not used, the differences related to the orientation are practically negligible. This is due to the fact that the buildings are almost completely shaded by the building on the opposite side of the narrow road. This, however, changes, when air conditioning is in operation. The addition of the rejected heat from the compressors of the air conditioning units, leads to the development of flow fields.

2. Bar, L. & Hoffman, M. (2003). Geometry and orientation aspects in passive cooling of canyon streets with trees.

This paper discusses the geometry and orientation aspects of the canyon street climate and how these aspects are affected and can be reconciled in the presence of trees shade. In the CTTC model (cluster thermal time constant), passive cooling of the street by solar heating attenuation is governed mainly by the street orientation and its geometry as measured by the aspect ratio of flanking buildings height to street width, At the early hours in the morning (say at 10:00 h), the solar azimuth angle in August is about 60° in Occupied Palestinian lands coastal region " Israel" (32°N). Hence, at this time, the N–S oriented street has about 73% more ground shading than its E–W counterpart ($\tan 60= 1.73$). Between 10:00 and 14:00 h, the shading effect in the two streets is reversed. On the other hand, in winter, in January, the solar azimuth angle at 10:00 h is about 33° ($\tan 33= 0.65$) thus, the N–S street is less shaded than the E–W. The total daily incident radiation is about the same in both cases, but the diurnal distribution differs significantly. And by additional thermal effects of trees, the result is about half of the net solar radiation is used up in latent heat-exchange. The study found that for suburban areas (50% green), the evaporative heat suppression (relative to a bare urban area, 0% green) is of the same order as the sensible heating, while in rural areas (100% green), where the vegetation is intensively irrigated, the latent heat is about 80% larger than its sensible heat. While green areas are not all trees, the findings are indicative.

3. Toudert, F. & Mayer, H. (2007). Effects of asymmetry, galleries, overhanging facades and vegetation on thermal comfort in urban street canyons.

This study deals with the dependence of outdoor thermal comfort on the design of an urban street in a hot environment. The effects of the street vertical profile, including asymmetrical canyon shapes, the use of galleries and further shading devices on the facades, arranged in various orientations are assessed. The study is conducted by means of numerical modeling by using the three-dimensional microclimate model ENVI-met 3.0. The results revealed that all design aspects investigated have a strong effect on the heat gained by a human body and hence on the resulting thermal sensation. The larger the openness to the sky of the canyon, the higher the heat stress. For canyons with a smaller sky view, the orientation is also decisive: E–W canyons are the most stressful and deviating from this orientation ameliorates the thermal conditions. Basically, galleries and further shading through vegetation enable a sensitive decrease of the area of thermal discomfort. Yet, this efficiency varies with the orientation and the vertical proportions of the canyon. Therefore, if appropriately combined, all investigated design elements can effectively promote thermal comfort.

4. Krüger, E., Pearlmutter, D., & Rasia, F. (2010). Evaluating the impact of canyon geometry and orientation on cooling loads in a high-mass building in a hot dry environment.

In this study, thermal simulation software was employed to evaluate the effect of different street canyon geometries on cooling loads of building in a dry environment – Sede-Boqer, located in the Negev desert, Occupied Palestinian lands "Israel". A residential building was monitored from January to August 2006 to calibrate the energy simulations in summer, using diverse solar geometries and axis orientations as input data. Simulations were carried out using the local TMY, taking into account different aspect ratios (H/W) which are 0.33, 0.66, 1 and 2 and street orientations are east–west, north–south, northwest–southeast and northeast–southwest. Results are shown in terms of energy consumption for cooling for each canyon configuration. For the Sede-Boqer site, comparison of the results from IDA–ICE and ENVI-met, in all cases, wind exposure is not as important as mutual shading and building orientation for the reduction of cooling loads. From the obtained results, general recommendations can be traced for urban planning in arid regions, which could help promoting energy-responsive buildings.

5. Bar L., Ioannis, X. & Hoffman T. (2012). Passive cooling design options to ameliorate thermal comfort in urban streets of a Mediterranean climate (Athens) under hot summer conditions.

This work investigates how to reduce air temperature at the street level and to improve thermal conditions for pedestrian in summers months. The case study is a street in Athens with high traffic, low aspect ratio H/W, and low trees canopy coverage level. Their thermal effect is separately and altogether estimated by applying the microclimatic Green-CTTC model whereas thermal stress is assessed using the Physiological Equivalent Temperature (PET) index which is a thermal index derived from the human energy balance - It is well suited to the evaluation of the thermal component of different climates-. The studied day is relatively hot with eight hours of heat stress at street level. Acceptable near-to-discomfort limits for local pedestrians are considered whereas Physiological Equivalent Temperature classification heat stress levels are adjusted to local conditions by applying a correction equation to obtained PET values. Results indicate that the examined cases are associated with air temperature decrease and improvement of thermal comfort, especially during the hottest day's. The trees thermal effect is the dominant factor followed by the increase of aspect ratio H/W and of the walls surfaces albedo. In addition, Alternative local smart controls for thermal comfort (SCAT) options are discussed in this study.

6. Rehan, R. (2013). Sustainable streetscape as an effective tool in sustainable urban design.

Sustainable streetscape plays an important role in forming the visual image of sustainable cities, as it is one of the most important factors which helps in city success. The research aims to activate the role of sustainable streetscape as an approach to provide an attractive and safe sustainable urban environment, and to sustain the development process for the visual image of cities, especially in Egypt, through focusing on the elements and basic principles of sustainable streetscape that should be taken into account to define sustainable streetscape. So that, the analytical study covers some international examples in applying the basic principles of sustainable streetscape in order to use it to develop streetscape of one of the main urban streets in Egypt. The research concludes the importance of developing urban environment visual image in Egypt, through directing urban planners and designers to the important role of streetscape in achieving sustainable development, in addition to identify the methods of application of sustainability in

streetscape, by taking into account principles of sustainable streetscape including stormwater management, use of sustainable materials, lighting & dark skies, and landscaping & urban heat island.

1.10 Conclusion

This chapter concentrated on displaying the problem of thermal discomfort in the buildings as a result of the absence of integration between climatic factors and street design. The importance of this issue increases with the energy crisis which is linked directly with the energy consumption in the buildings. The chapter focused on the street morphology as it is considered one of the most important strategies in the urban design process. It assumes that the climatic design of streets has a great influence on the thermal comfort inside and outside buildings and thus energy demand. In order to evaluate this assumption, simulation processes using thermal analysis programs will be carried out in this study.

The chapter presented some previous studies that dealt with similar subjects. The mentioned studies discussed different factors affecting thermal comfort in urban street canyons, but there are no adequate studies to examine the effect of street design on energy consumption especially with respect to a Mediterranean climate. It is worth noting that most of these studies addressed the contribution of street design toward the development of a comfortable microclimate at a street level. However, the impact of streets configuration with architectural details were not studied extensively, especially with regards to solar radiation falling on facades and thus indoor thermal performance.

Chapter 2: Energy Efficiency of Urban Design

2.1 Introduction

The energy performance of urban streets and buildings, both in terms of energy needs and of actual energy use, has long been an object of the attention of architects and urban planners, because it is one of the most important factors which helps in city success. Nowadays the world is facing a large challenge due to energy shortage. Thermal performance deals with the heat flow between buildings and outdoor environment to improve thermal conditions in urban streets and indoor spaces. Thus, knowledge of the methods of estimating the performance of buildings and shading and solarization areas on the street are essential for energy-efficient urban design (Pisello, Bobker & Cotana, 2012; Housing Development & Management, 2009).

This chapter is carried out to introduce an overview about energy related environmental problems. It highlighted the energy efficiency and renewable energy as a good solution. Then, the chapter discussed energy efficiency for urban design and explain strategies of energy efficient urban design which include site selection and orientation, density, climate optimisation, buildings and transport. The chapter dealt with effects of urban design on comfort outdoors. In addition, the research highlighted thermal performance of buildings and explained the modes of sensible heat transfer which include conduction, convection and radiation. Also, it overviewed the factors that affect the thermal performance which are building form, orientation, shading devices, material properties, ventilation and building usage.

2.2 Energy efficiency and renewable energy

Energy is vital to the people well-being. It provides personal comfort, and is essential to most industrial and commercial activities. However, energy production and consumption practices place considerable pressures on the environment, including contributing to climate change, damaging natural ecosystems and tarnishing the built environment. One way to reduce the environmental pressures of energy use is to limit the demand for energy-consuming services or to provide these services with more efficient devices this process is called energy efficiency. Also, renewable energy sources are seen as an increasingly important alternative for reducing the pressures placed on the environment by energy

production and consumption, it can contribute to the security of energy supply by replacing fossil fuels (Ryan& Campbell, 2012).

2.2.1 Environmental effects of energy use

Using fossil conventional sources to produce energy causes several environmental effects including global warming, air pollution, acid precipitation, ozone depletion, forest destruction and emission of radioactive substances (Bradshaw, 2006). The enormous use of energy in buildings is one of the major central reasons for the environmental pollution problem and the main responsible of global warming. Burning fossil fuels to obtain electricity caused pollution of the air, water and soil (Bearden, 2000). In addition, the atmospheric concentration of carbon dioxide has increased by 31% since 1750, causing climate change phenomenon which is one of the defining issues of our time. There has been a 2 to 4% increase in the frequency of heavy precipitation events in the mid- and high latitudes of the Northern hemisphere over the latter half of the 20th century (IPCC, 2001).

2.2.2 Energy efficiency

Department of Energy and Climate Change (2012) defined energy efficiency as " a measure of energy used for delivering a given service. Improving energy efficiency means getting more from the energy that we use". Energy efficiency belongs at the core of a low-carbon economy. By minimizing energy use and cutting down on waste, energy system become more sustainable and greenhouse gas emissions will drive down. According to ADEME (2004), assessing energy efficiency means measuring the overall effect of all the improvements at the micro-level about the evolution of the consumption of energy, energy efficiency improvements indicate to a reduction in the energy consumption for a particular energy service (heating, lighting, etc.) or level of activity. This reduction in the energy used is not always linked with technological changes, since it can also result from behavioral and economic changes (ADEME, 2004). There are various ways to improve energy efficiency according to Department of Energy and Climate Change (2012), for example:

- ‘Innovation’ can lead to the equal or greater output with less energy.
- ‘Cutting out wasted energy’ limits energy needed at the same time protect output.
- ‘Heating technologies’ can achieves greater output for less supplier energy.

The effect of energy efficiency improvements in OECD countries reduced growth in final energy consumption. The energy consumption was decreased by 63% during the period 1973 – 2006 as a result of energy efficiency improvements, see figure (2.1).

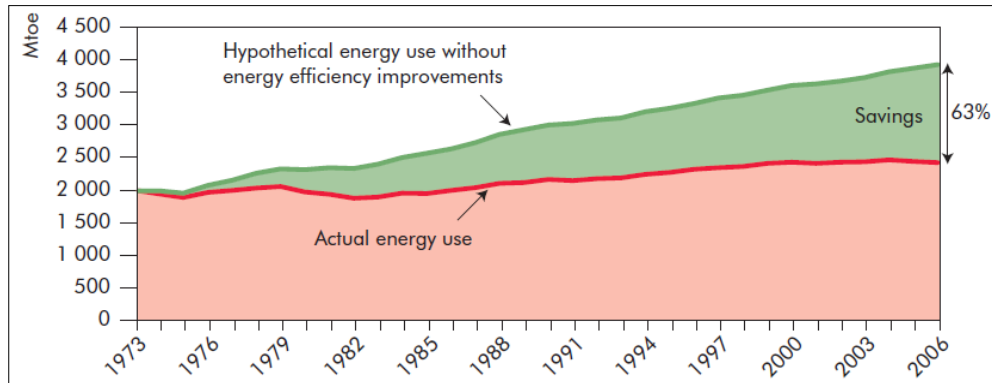

Figure (2.1): Long-term energy savings from improvements in energy efficiency, OECD.
Source: International Energy Agency (IEA), (2010)

2.2.3 The benefits of energy efficiency

Energy efficiency improvements can achieve great multiple benefits across a wide range of sectors. U.S. Environmental Protection Agency (2011) summarized the benefits of energy efficiency as follow:

- Reduce greenhouse gas emissions and other environmental impacts.
- Reduce energy costs.
- Increase economic benefits through job creation and market development.
- Demonstrate leadership.
- Improve indoor air quality and productivity in energy-efficient.
- Engage the community.

2.2.4 Renewable energy

The renewable energy refers to electricity generated from renewable resources (water, wind, sun, geothermal and biomass) and fuel cells. These elements are the most abundant in the universe. The use of solar energy or photovoltaic (PVs) for the everyday electricity requirements has obvious advantages: avoids resources consumption and deterioration the environment through emissions, oil spills and toxic by-products (Khalil, 2014). It is important to have a great increase in using the natural resources to achieve sustainable development and economic growth and to avoid climate change (Karasu, 2010).

On the other hand, there are disadvantages of renewable energy includes its variability, low density in some places and high initial cost. For example, the earth surface don't get the same amounts of solar radiation and the locations far away from the equator don't have enough irradiation intensity to generate the system. Yet, renewable energy is still the best alternative available instead of conventional sources (Sen, 2008).

2.2.5 Cross cutting issues for energy efficiency and renewable energy

Energy efficiency and renewable energy are two complementary and necessary to achieve sustainable development, both contribute substantially towards reducing CO2 emissions, curbing energy demand and providing alternative carbon free supplies (European Communities, 2006). Synergies between energy efficiency and renewable energy's can be exploited in several methods according to ECREEE (2012):

- Energy efficiency measures, by reducing total energy consumption, allow renewable energy systems to meet a greater part of demand, thus minimizing the need for systems of fossil fuel, and facilitating achievement of renewable energy goals.
- Energy efficiency contributes to optimizing the use of off-grid systems depended on renewable energy.
- Technologies of energy efficiency and renewable energy in buildings are complementary: onsite renewable energy systems for cooling, water heating and electricity production can be optimized through energy efficiency measures.

2.3 Energy- efficient urban design

Energy- efficient urban design appreciates the importance of establishing carefully designed, humane and inclusive urban environments to create energy-saving urban environments, thereby promotes health and wellbeing among urban residents. In addition, energy efficiency has become one of the major considerations within urban design. Energy efficiency urban design offers opportunities to improve the quality of urban life through providing spatial solution, designed for a healthy and comfortable- built environment with minimum energy consumption.

2.3.1 Definition of urban design

INFRA (2011) stated that urban design operates from the macro scale of the urban planning to the micro scale. DETR (2000) mentioned that urban design is an art of designing places for people. It is one of the important elements in urban planning. It concerns about the connections between people and places, the physical and spatial arrangement, creation of spaces for movements, nature and the built fabric, and the process for improving the overall townscape. It focuses on design of the public domain, which is formed by both public spaces including streets, squares, parks, waterways and other spaces and the buildings that define them. Good urban design enhance how buildings are oriented towards the street and corridors are planted to buffer between pedestrians and vehicular (horizon, 2009).

2.3.3 Principles of energy efficiency for urban design

The following principles form the basis for the energy efficient urban Design guidelines as mentioned by MED-ENEC (2013):

- Take advantages of climatic conditions of the site to support sustainable passive urban design strategies for heating and cooling techniques and energy efficient indoor and outdoor comfort.
- Promote energy efficient transport modes such as (mass) public transit and non - motorized transportation (such as biking and walking).
- Promote compact urban densities to support economic feasibility of public facilities. Integrate residential functions in mixed-use project, and distribute services within short distances.
- Provide comforts for outdoor and indoor environment.
- Accommodate renewable energy solutions through integration and flexibility in planning and design, to further reduce the carbon emissions.

2.3.4 Strategies of energy efficient urban design

Urban design environmental strategies should be based on the basic of inclusive understanding of the climate, geography, culture and traditions of a location (ENERGIE, 2000). Climate responsive urban areas involves the organization of buildings, streets and open spaces should be provided access to the site resources of sun, wind and light that are

necessary for passive heating, cooling and lighting of buildings (DeKay, 2003). Energy efficient urban design and planning should promote an environment which offers diversity, productivity and protection. ENERGIE (2000) summarized strategies of energy efficient urban design as follow:

2.3.4.1 Site selection and orientation

Site Selection should allow the designer to maximize the use of natural resources on the site. Studying urban design, which involves a relation between the geometry form and the received solar radiation has great significance. In cold climates, the form should receive as much radiation as possible, while in hot conditions, the same form should decrease undesirable solar impacts (Al-Qeeq, 2008). So, seasonal variations in solar radiation and wind flows should be taken in to account when selecting the site. Passive solar site layouts should seek to trap the heat generated by the sun to reduce fuels consumption by good arranging of the form and fabric of a building and the site layout. In U.K. Passive solar homes can have a heating energy consumption up to 2000KWh a year lower than the conventional home, see figure (2.2). These benefits depend upon the arrangement of the site to produce the best orientation (Planning and Environment Services, 2004).

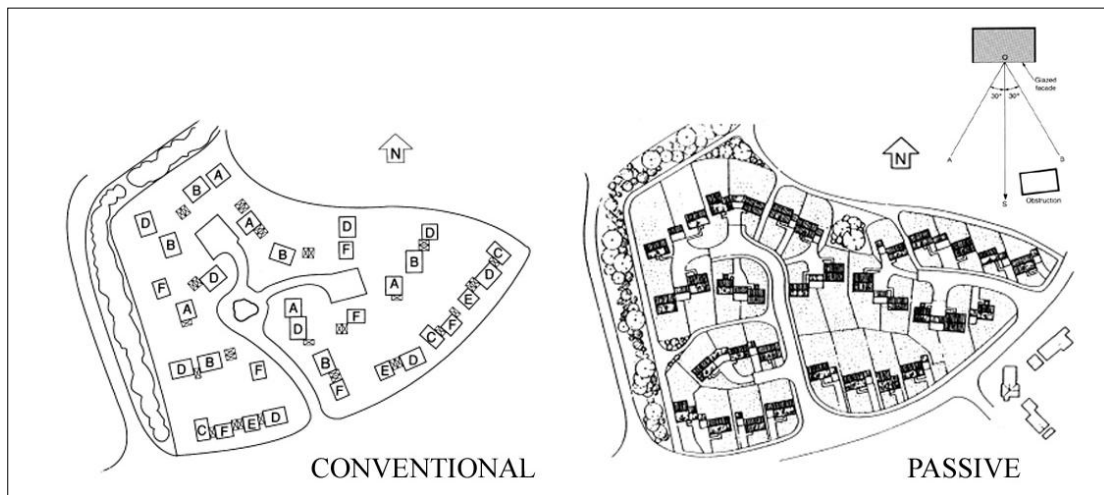

Figure (2.2): Passive solar site layouts with main solar collecting facades of houses facing within 30 degrees of due south can achieve space heating savings of over 10% compared to conventional layouts.

Source: Planning and Environment Services, (2004)

In addition, Littlefair (1998) studied the concept of obstruction height within a particular angular area on horizontal plan in U.K. to get appropriate obstruction angle at

centre of solar facade less than critical value within zone between SE and SW. The best area to keep the good amount of light and solar access obstructed is within 30° either side of due south of a solar collecting façade, see figure (2.3). To ensure winter sun it should not open more than the critical angle h . Table (2.1) gives values for h . Note that the values of h are given in terms of site latitude.

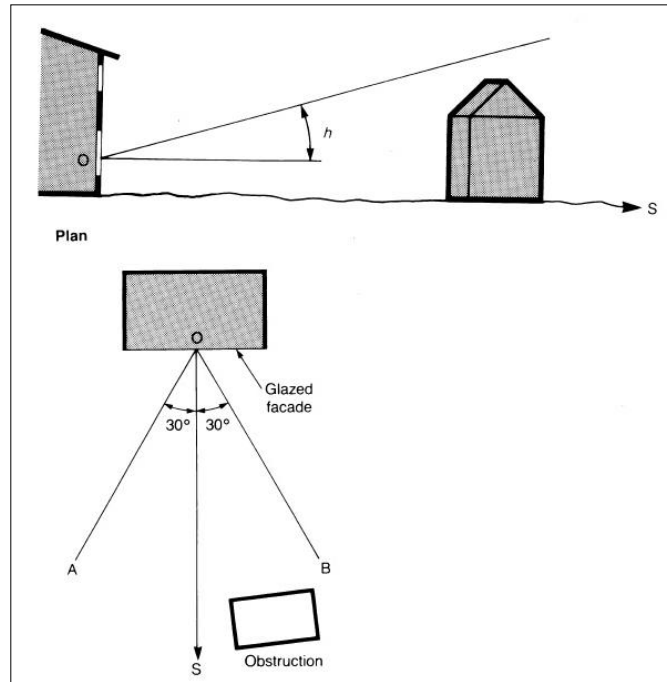

Figure (2.3): For solar access the area of sky between SE and SW becomes important.
Source: Littlefair, (1998)

Table (2.1): Limiting obstruction angle h to ensure at least 3 hours sun in specified period
Source: Littlefair, (1998)

Period of year	Value of h (degrees)
All year	65° - latitude
21 January-21 November	68° - latitude
6 February-6 November	72° - latitude
21 February-21 October	78° - latitude

2.3.4.2 Density

Density is a critical typology in determining sustainable urban forms. It is the ratio of dwelling units to land area (Cuthbert, 2006). Skinner (2006) summarized the methods for controlling density as plot coverage, plot ratio and dwelling units per specified area.

Plot coverage: Site coverage is protection sunlight and daylight within or closed to layouts or buildings. The site coverage is defined by dividing the total area of ground covered by

buildings by the total ground area within the cartilage of the buildings (Khan, 2008). High ground coverage of buildings in an urban area reduces the air space available for air ventilation. It is important to reduce site coverage to allow more open space by providing non-building areas to allow air penetration, encourage setbacks along narrow streets and providing green areas to improve the urban climate for pedestrian (CUHK, 2012), see figure (2.4).

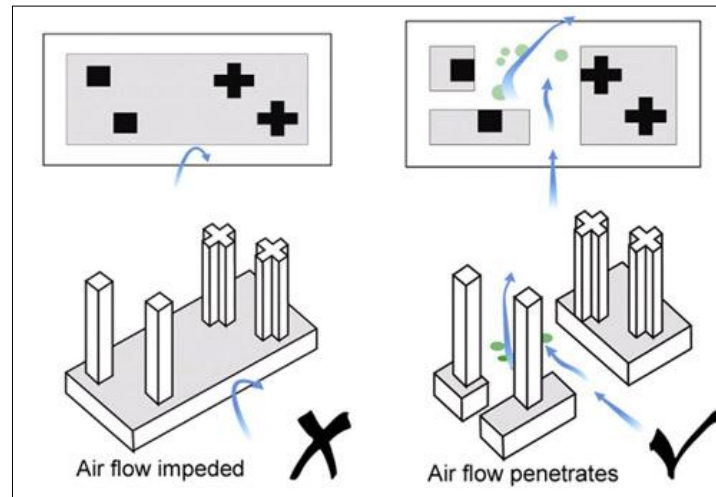

Figure (2.4): reducing site coverage to allow more open space at grade
Source: CUHK, (2012)

- **Floor area ratio:** FAR = (Total covered area on all floors of the building on a plot)/ (Area of the plot). Thus, an FAR of 2.0 would mean that the total floor area of a building is two times the total area of the plot on which it is built (Khan, 2008).

- **Dwelling units per specified area:**

Dwellings per hectare is the most suitable measure in order to estimate development land needs, making housing land allocations, control completions/take up and in providing a broad indication of the intensity/form of development on a site (Forsyth, 2003).

1. Density and building energy

Stemers (2003) pointed out that more intense use of site and sharing of infrastructure reduces the energy per capita and increase benefits from economies of scale in comparison with a dispersed urban form. Promoting the concept of “decentralised concentration and high density mixed land-use” can reduce the distances that people need to travel to access services. Thus, reduce energy consumption. According to Sam (2001), there was an inverse

relationship between residential population density and energy consumption; higher population densities are linked with lower energy consumption, and lower densities with higher energy consumption. Another study looked at the effect of urban density on daylight and passive solar gains in office and domestic buildings. The study found that there is in general an increase in energy consumption as density increases (Stromann-Andersen & Sattrup, 2011).

2. Density and microclimate

Generally, In Middle Eastern housing high-density development has a significant benefits in terms of microclimate, for example, temperature in narrow street in Morocco 6-10 degrees lower than exposed locations (Johansson, 2006). In contrast, Skinner (2006) found that higher urban density in Melbourne has negative effects on the microclimate and the hydrology of the city.

2.3.4.3 Climate optimisation

ENERGIE (2000) summarized climate optimisation as solar radiation, wind, temperature, relative humidity and air quality.

1. Solar radiation

The incident solar radiation is considered the main responsible factor affecting the outdoor microclimate. Radiation can be defined as radiation from the sun or the radiation emitted by objects on earth (Shahidan et al., 2010). The aim when studying solar access is to design for maximum desirable solar radiation in winter, while protecting against undesirable solar radiation in summer (ENERGIE, 2000). Solar radiation falling on the earth can be divided into two components: beam radiation and diffuse radiation. Beam radiation includes parallel energy rays, coming straight from the sun, while diffuse radiation is scattered and includes non-parallel rays. The total solar radiation incident on the earth's surface is measured on a horizontal surface. In addition, a secondary effect of solar radiation (the beam and diffuse radiation) is the reflected radiation which comes from the building's surroundings and adjacent surfaces. The beam solar radiation is divided into two parts: the first is absorbed by the external surfaces of the building and the second transmitted through windows into the building spaces (Kontoleon, 2012). These factors (reflection, absorption, and transmission) depends on albedo of the surface, which is the ratio of reflected radiation from the surface to incident radiation upon it. Thus, it depends

on the frequency of the radiation. An object which has high albedo (near 1) is bright while an object which has a low albedo (near 0) is dark, (Taha, 1997; Shahidan et al., 2010). Also, irradiation on a surface depends on its orientation and on the azimuth and altitude angles of the sun (Housing Development & Management, 2009). Figure (2.5) shows the two angles: the sun's altitude and the azimuth. The most intense solar radiation occurs when the sun's rays strike the earth at the highest. During the summer months, irradiation remains at a high level, but starts to fall off in September. As the solar altitude angle decreases, the beam radiation is spread over a larger area and decreases in intensity due to the atmospheric absorption. The earth is inclined towards the sun throughout the summer resulting high sun angles. On the other hand, the earth is oriented away from the sun in winter, creating low altitude angles (Kontoleon, 2012).

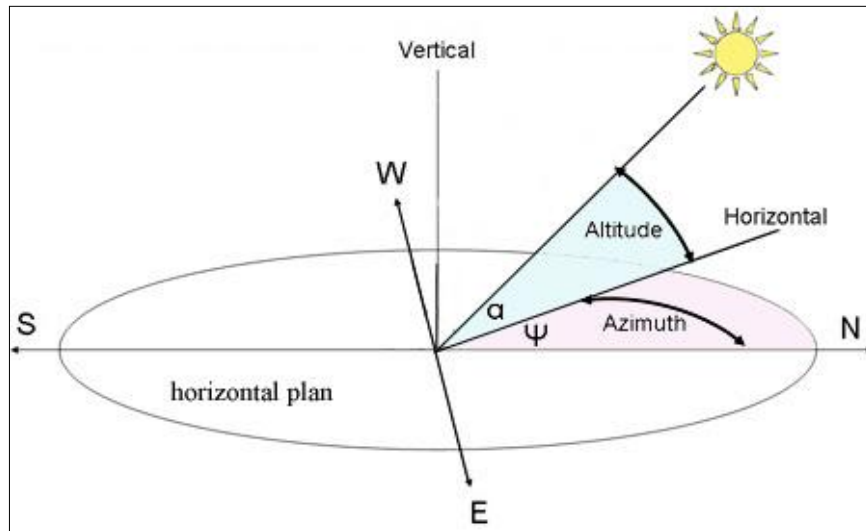

Figure (2.5): Solar altitude and azimuth
Source: Kontoleon, (2012) (adapted by author)

At the winter solstice specifically in December 21 the axis tends away from the sun therefore, in the northern hemisphere, the sun rises south of east; the earth moves low across the southern sky, the sun sets south of west. In contrast, at the summer solstice specifically in June 21 the days are longer and the sun rises higher in the sky. At this time the sun rises north of east and sets north of west (Kontoleon, 2012; American Meteorological Society, 2012).

It is worth mentioning that the amount of solar radiation reaching the earth's surface varies depending on three factors. First, angle of incidence which describes the angle between the incidence ray and a perpendicular line on the surface. According to the cosine

law the radiation received by a surface is the normal radiation multiplied by the cosine of the incidence angle. There was an inverse relationship between incident solar radiation angle on surface and solar radiation percentage; higher angels are linked with lower percentages of solar radiation, and lower angels linked with higher percentages, see table (2.2). Second, factor of variations in cloud cover and atmospheric pollution. Third, the duration of sunshine, where solar radiation during summer is more than during winter due to the length of daylight hours (Szokolay, 2004; Burgos et al. 2008).

Table (2.2): The relationship between incident solar radiation angel and solar radiation percentage.

Source: ElHissi, 2012 (adapted by author)

Incident solar radiation angel on surface	Solar radiation percentage (%)
0°	100
5°	99.6
10°	98.5
15°	96.5
20°	94.0
25°	90.6
30°	86.6
35°	81.9
40°	76.6
45°	70.7
50°	64.3
55°	57.4
60°	50.0
65°	42.3
70°	34.2
75°	25.9
80°	17.4
85°	8.7
90°	0.0

As figure (2.6) shows, around 31% of solar radiation reaching the earth's surface is reflected, while the remaining 69% enters the terrestrial system. Part of this energy is absorbed by the atmosphere before reaching the ground and about 50% reaches the ground surface. This proportion is not fixed but varies according to the atmospheric conditions (Szokolay, 2004).

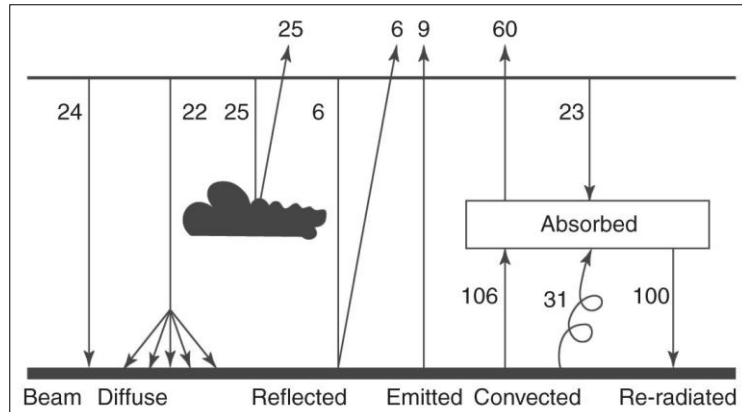

Figure (2.6): Radiation balance in the atmosphere
Source : Szokolay, (2004)

On the other hand, the amount of diffuse irradiation received at street depends on the sky view factor (SVF), which is the part of the sky seen from the street, see figure (2.7). There was a positive relationship between diffuse radiation and sky view factor, the diffuse radiation decreases with decreasing sky view factor (Housing Development & Management, 2009).

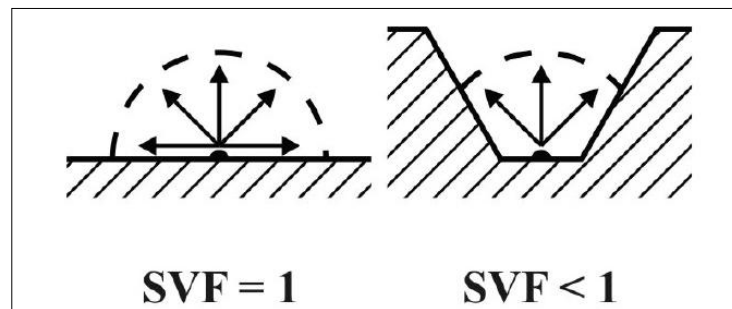

Figure (2.7): sky view factor (SVF) of an urban street canyon
Source: Hämmerle et al., (2011)

2. Wind

Wind speeds have a great impact on thermal comfort in urban areas, wind in a continuous change, both in the flows direction and in its speed. Each region in the world has wind rose that shows the prevailing direction of the wind that can't be ignored in building design (Brown & Gillespie, 1995). Non simple geometric forms of urban areas including of buildings with complex configuration and sharp edges, clearly affect the regional winds blowing through and over a city. Local wind speeds in urban areas can exceed wind speeds in the rural areas, especially when urban areas contains high-rise buildings (Housing Development & Management, 2009). Urban air flow depends on Building Height/Street Width (H/W) ratio. An inverse relationship is found between areas density and effective in promoting air ventilation. In low density areas with (H/W) of 2 and

below, building height control is effective in promoting air ventilation, but high densities areas, controlling building heights is less effective, see figure (2.8). In general, gradation of building heights would help wind movement. Building height variation across the site and decreasing buildings height towards the prevailing wind direction should be adopted to enhance air movements (CUHK, 2012), see figure (2.9).

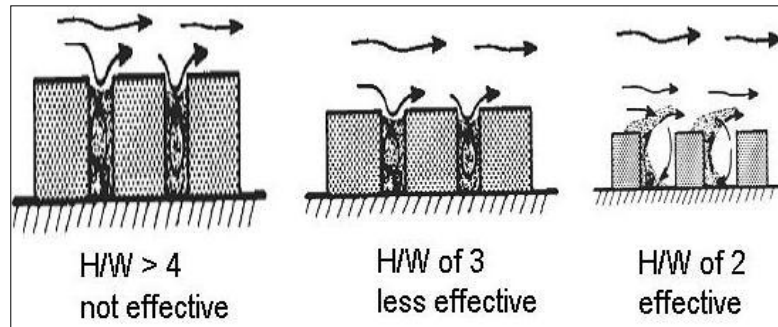

Figure (2.8): Urban air flow depends on Building Height/Street Width (H/W) ratio
Source: CUHK, (2012)

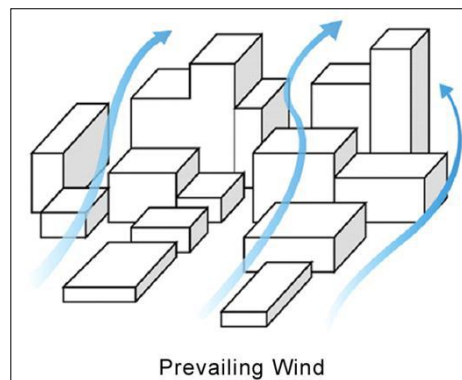

Figure (2.9): Prevailing wind direction enhance air movements
Source: CUHK, (2012)

3. Temperature

Temperature describe the physical states of matter that quantitatively expresses the common notions of cold and hot, objects of low temperature are cold, and objects of high temperature are hot (Ritter, 2009). In urban climate, it is known that cities are warmer than rural areas. The difference in daytime temperature between urban and rural areas is normally smaller, see figure (2.10). Field measurements in many cities have illustrated that the magnitude of nocturnal heat islands increases when H/W ratio increasing. When the urban canyon is a well absorber of solar energy, it is stored in the fabric and not released until after sunset (Housing Development & Management, 2009). Vegetation can have a great impact on air temperature, trees can modify air temperature by preventing solar

radiation and cooling the surrounded area by evapo-transpiration process, so green areas are cooler than built-up areas (Valsalakumari, 2008).

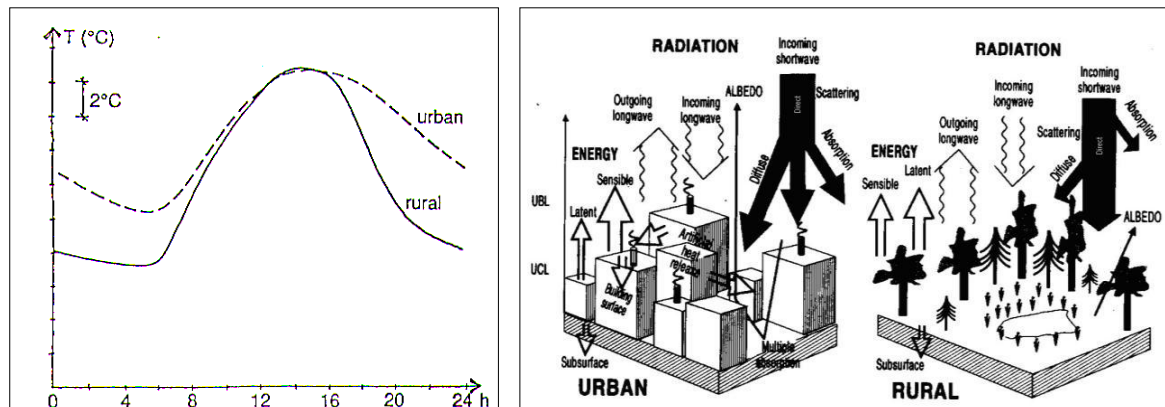

Figure (2.10): L: Temporal variations of air temperature in an urban area and its rural surroundings, R: Perspectives shows an urban and rural areas.

Source: Housing Development & Management, (2009)

4. Relative humidity

Humidity commonly indicates to relative humidity that expressed as a percentage of water in the weather, therefore it affects the energy and thereby influences temperatures. Trees play an important role in increasing humidity especially in summer through transpiration. Humidity is high under dense trees, the more Leaves of tree; the greater is the amount of water added to the air (Valsalakumari, 2008, Federer, 1976). Relative humidities under planting can be 3% -10% higher than in built-up areas (ENERGIE, 2000). Therefore, urban areas are slightly more humid at night and dryer in the day than rural areas.

5. Air quality

Urban air pollution was associated with domestic heating and industrial emissions, which are now controllable to a great extent. High pollution levels have been noted in urban street canyons due to the increased traffic emissions and reduced natural ventilation (Vardoulakis et al., 2003). In areas where air quality is poor, many types of plants can absorb great levels of common urban pollutants such as CO₂, NO_x, SO₂, and improve the air quality through their leaves by filtering particulate matter from the air (ENERGIE, 2000).

2.3.4.4 Buildings Envelope

A building's envelope affects outdoor thermal comfort, by its thermal mass, solar reflectance and transmittance. When building materials exposed to direct solar radiation, it

stored this as heat in the fabric and released it after a time period depending on the reflectance and heat storage capacity of the material, therefore external spaces used after sunset will benefit from stored heat especially for cold climate (ENERGIE, 2000). Building forms should aim to maximize day lighting, solar energy and shelter depending on the climatic parameters. Buildings should be designed to encourage natural ventilation by promoting building gaps and separations to facilitate air flow and prevent create large wind wake areas (CUHK, 2012), see figure (2.11).

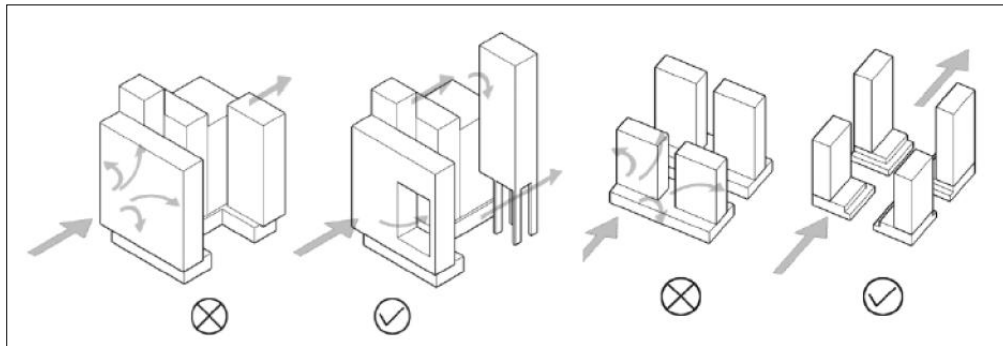

Figure (2.11): Buildings should be designed to encourage natural ventilation
Source: CUHK, (2012)

2.3.4.5 Transport

Transport is one of the biggest issue for environmental issues relating to urban form where the form of most cities reflects the transport systems that were dominant at different stages of their development (Jabareen, 2006). Clercq and Bertolini (2003) defined sustainability as “diminishing both mobility and the negative of traffic.” According to Duncan and Hartman (1996), a sustainable urban transportation system reduces vehicle emissions and waste and reduces the use of land by urban zoning to minimize travel distances and the provision of facilities which promote low or zero energy modes of transport, thus provides equitable access for people and goods and helps achieve a desirable quality of life.

2.3.5 Urban design and comfort outdoors

The external environment has a great impact on living conditions, which is determined by natural conditions, anthropogenic factors, the density of urban structures and the size of vegetation areas, etc. (klemm, 2007). The increasing number of buildings in a neighborhood and reduction of landscaping affect the condition of microclimate in urban spaces, which can influence the use of outdoor space. Thermal comfort of people staying

outdoors influence outdoor activities in streets, plazas, playgrounds and urban parks. People are affected by variability in the exposure circumstances, such as variant in sun and shade, modifications in wind speed and direction and change in humidity rate (Givoni et al., 2003).

2.3.5.1 Outdoor thermal comfort

Thermal comfort is defined as ‘that condition of mind which expresses satisfaction with the thermal environment’ (Taleghani et al., 2014). Thermal comfort in the outdoor environment is mainly related to thermo-physiology, i.e. physiology and the heat balance of the human body (Höppe, 2002). There are four environmental variables affecting thermal comfort of a human body: air temperature, mean radiant temperature, air humidity and air speed. In addition, two personal variables influence thermal comfort: clothing and the level of activity. Other personal factors related to adaptation and acclimatization has proven to affect thermal sensation (Ghazizadeh, Monam & Mahmoodi, 2010). It is extremely complex to determine the outdoor mean radiant temperature (MRT) due to the extensive variation in radiation from various sources. The human body may receive direct and diffuse solar radiation, as well as reflected radiation from building façades and the ground. In addition, the body exchanges long-wave radiation with the sky, urban surfaces and with objects such as trees, see figure (2.12). Therefore, the most accurate method to identify the outdoor MRT is by measuring the short and long-wave radiation from several points (Housing Development & Management, 2009).

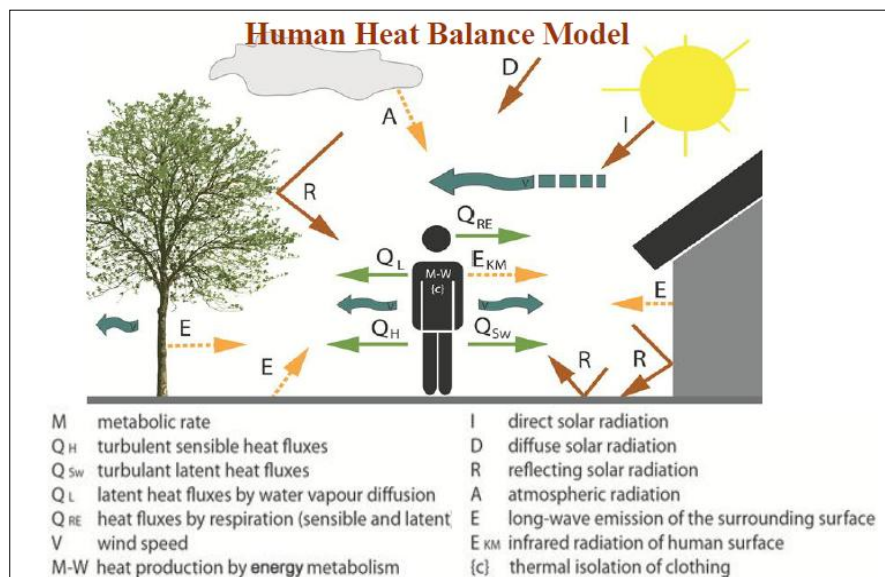

Figure (2.12): A person exposed to direct (I), diffuse (D) and reflected (R) short-wave radiation as well as long-wave radiation from the sky and the urban surfaces

Source: CUHK, (2012)

2.3.5.2 Effects of urban design on comfort outdoors

A number of urban design studies show a real consciousness in climatic design, either by exploiting the potential of natural energy or by protecting people from adverse climatic conditions. These studies provided some of arrangements deal directly with urban design especially urban street canyon. Investigations based on scientific methods proved the efficiency of commonly used street design concepts on outdoor thermal comfort. Available studies are reported and discussed below:

Pearlmutter et al. (1999) carried out the first investigation which highlighted the amount of radiation within urban canyons as well their impact on a human body. Measurements were carried out in the arid Negev region in street canyons with an aspect ratio H/W of 1, with different orientations, at the centre of the street and on the roof. The canyon is described as “cool island” due to solar shading from various radiation sources. A person standing on the unobstructed roof gained more radiant heat in comparison to a pedestrian. However, the absolute dimensions of the street in respect to human size ($H = W = 3$ m) are responsible for a great shading benefits and this may differ in larger canyons.

Swaid et al. (1993) conducted one of the first investigations on outdoor thermal comfort directly associated with street design. They considered street canyons geometry with an aspect ratio H/W of 0.5 and 1, oriented E-W and N-S and located in the Mediterranean climate in Tel Aviv ($32^{\circ}N$). The researchers found that the comfort conditions are more responsive to aspect ratio than to street orientation. E-W streets are uncomfortable between 14:00 and 18:00 LST for $H/W = 0.5$ and all the day for $H/W = 1$. This was due to shading from the building facades, which - according to the sun course- is more efficient for a N-S orientation than for an E-W orientation. Air temperature in an E-W street without a gallery is found to be higher than in a street including gallery. The researchers advised the use of additional shading devices to reduce the heat stress, either by landscaping or by means of arcades on the sidewalks.

Similarly, Coronel and Alvarez (2001) studied the thermal properties of confined urban spaces in Santa Cruz, Spain in the summer. The researchers found that reducing the dimensions of a street is extremely important in the thermal performance of these spaces, which was compared to an oasis effect. Air temperature decrease of 8 K for narrow streets

(H/W = 5) in summer was recorded. This was attributed to the reduced solar access and to the use of white colours.

2.4 Thermal performance of buildings.

The thermal performance is considered one of the most important aspect of energy utilization in buildings. It attempts access to a comfortable temperature internally, by keeping the internal temperature higher than or lower than the external temperature. Thermal comfort is an important parameter in passive solar buildings in which solar energy is collected, stored and distributed (Goulding et al., 1992). This section will display a review of thermal performance, the mechanisms of thermal transfer and climatic design and its effect on indoor thermal comfort.

2.4.1 Definition of Thermal Performance

Thermal Performance is "the process of modeling the energy transfer between a building and its surroundings" Nayak & Prajapati (2006). It is a critical factor in the amount of energy used in buildings. It refers to how well a structure responds to changes in external temperature during the daily and seasonal cycles. Thermal performance can make a significant contribution to reducing the overall building energy usage and to maintain a steady comfortable temperature inside and outside (Government of Ireland, 2010).

2.4.2 Assessing thermal performance

Energy conservation is dependent on the ability of building components in reducing the heat outflows from the inside of the building to the outside (Rhee, Duverne & Baker, 2013). This ability is described in terms of its thermal transmittance or U-value (W/m².K), which is expressed as the heat flow through one square meter of a structure when the temperature differs on either side of the system by one degree Celsius. Therefore, the U-value is dependent on the thermal conductivities of the building materials and their respective thicknesses structure. The lower the U-value, the better is the thermal performance of a structure, indicating higher levels of insulation (Baker, 2011). Generally, U-values are calculated with readily available software programs.

2.4.3 Impact of Thermal Performance on Energy Consumption

There is a clear relationship between the energy consumption of buildings and their thermal performance. The heat transfer through the building elements, in a mean of heat gains or losses adding to the internal heat gains and ventilation gains are considered the most major factors affecting the thermal performance (Ghisi & Massignani, 2007). The most important factor on energy consumption is the heat transfer coefficient of wall, then the building shape coefficient (Yu et al., 2011). On the other hand, thermal response determines the required heating and cooling energy to maintain acceptable thermal comfort conditions for people (Aye et al., 2005).

2.4.4 Heat balance

Bradshaw (2006) pointed out in his study that the humans burn food for energy and must discard the excess heat and this is accomplished by evaporation coupled with the three modes of sensible heat transfer: conduction, convection, and radiation. He added that a very narrow range of body temperature must be maintained and the heat must not be lost too fast or too slowly. This major factors will be outlined.

Conduction: it is the energy transmission from the more active particles of a substance to the adjacent less active ones as a result of interactions between the particles. Conduction can take place in solids, liquids, or gases (Introduction to Thermodynamics, 2008). Conduction needs the physical contact of two particles such as the different component of building envelop, where heat is conducted from the warmer to the cooler side (Roos, 2008).

Convection: it is the method of energy transfer between a solid surface and the contiguous liquid or gas, and it involves the combined effects of conduction and fluid motion (Gabriel & Vasile, 2011). Energy transfer by convective occurs from air outside of the building to the outer surface of the wall and the inner surface of the wall to the air inside of the building (Mahlia et al., 2007).

Radiation: it is the energy emitted by matter in the form of electromagnetic waves (or photons) as a result of the changes in the electronic formulation of the particles (Introduction to Thermodynamics, 2008). The solar radiation which transmitted through the transparent surfaces such as glass and absorbed by the building is radiated again from the interior surfaces (Torcellini, 2001).

Evaporation: it is exclusively a cooling mechanism, sensible heat here is flowed from the skin to the surrounding air. The amount of this sensible heat depends upon the temperature different between the skin and air (Baker, 1987).

These four ways are illustrated in figure (2.13), which also shows the relative percentage in a normal comfort situation.

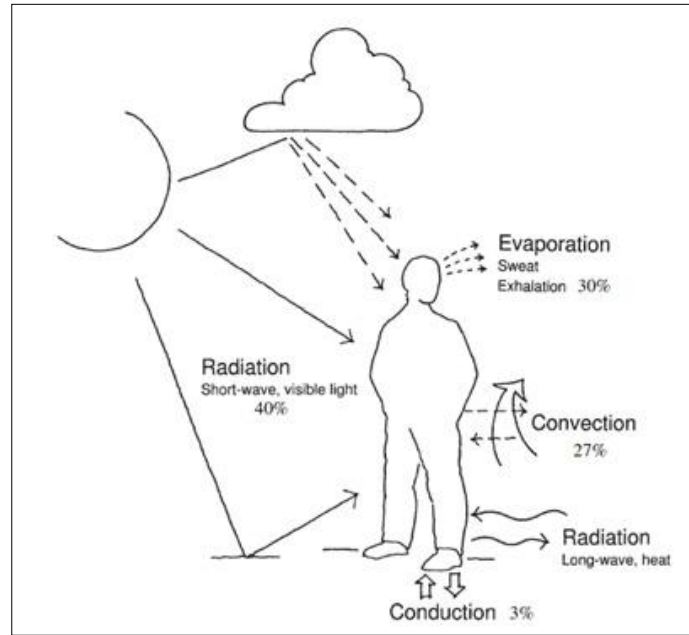

Figure (2.13): Mechanisms of heat loss from the human body and relative magnitudes for a resting person.

Source: Rosenlund, (2000)

2.4.5 Determinants of thermal comfort

Human thermal comfort is a combination of a subjective sensation and several objective interaction with the environment. Comfort is not just a physiological problem but psychological too. Martinez has grouped a several physical magnitudes as follow (Martinez, 2014):

- **Person-related:** it depends on external conditions, insulation properties of clothing which are an important factor in body heat gain and thermal comfort according to its type and thickness and on activity levels where the chemical energy is converted into heat (Bradshaw, 2006). In addition, it depends on age and risk groups (babies, elders, ill persons), previous accommodation (e.g. changing from indoors to outdoors), habits (e.g. clothing difference among seasons and sex), personal preferences (some people feel comfortable cold or hot), and actual mood (the state of mind, feeling happy or nervous).

• **Environment-related:** include air temperature (T_a) that depends on the difference in temperature between the skin and the surrounding air, vapor pressure (P_a) which transfer heat from the body to environment and cooling the body, wind velocity (V_a) which has a significant effect on the evaporation process of moisture from the skin and also has effect on heat loss. And mean radiant temperature (T_{mrt}) which depends on direct solar irradiance, sky temperature, wall solar reflectance and wall temperature (Bradshaw, 2006; Monam & Rückert, 2013).

There has been a directed to combine all climatic variables in apparent temperature, and all personal response in a few degrees of comfort or not. Table (2.3) shows the seven - scale thermal feeling:

Table (2.3): The seven-scale thermal feeling
Source: Martinez, (2014) ; ISO, (1994)

Sensation		PMV
Uncomfortable cold	when >95% of people in a significant group complain of being cold.	-3
Cool, or bearable cold	when some 75% of people in a significant group complain of being cold.	-2
Slightly cool	when only some 25% of people in a significant group complain of being cold.	-1
Comfortable	when <5% of people in a significant group complain of being cool or warm.	0
Slightly warm	when only some 25% of people in a significant group of being hot.	+1
Warm, or bearable hot	when some 75% of people in a significant group complain of being hot.	+2
Uncomfortable hot	when >95% of people in a significant group complain of being hot.	+3

Based on the above discussion of the thermal comfort magnitudes, it can identify the comfort zone which illustrate the acceptable comfort conditions. The comfort zone is a thermal condition in which little effort is required by people to adapt their bodies to surrounding environmental conditions (Cakir, 2006). Figure (2.14) shows Olgyay' s bioclimatic chart which was one of the first attempts to determine different areas at different sets of relative humidity and dry bulb temperatures. It shows that comfortable temperature ranges from about 20°C to 30°C. The comfort level is applicable to indoor spaces with the indoor level of clothing (Azri , Zurigat & Al-Rawahi, 2012).

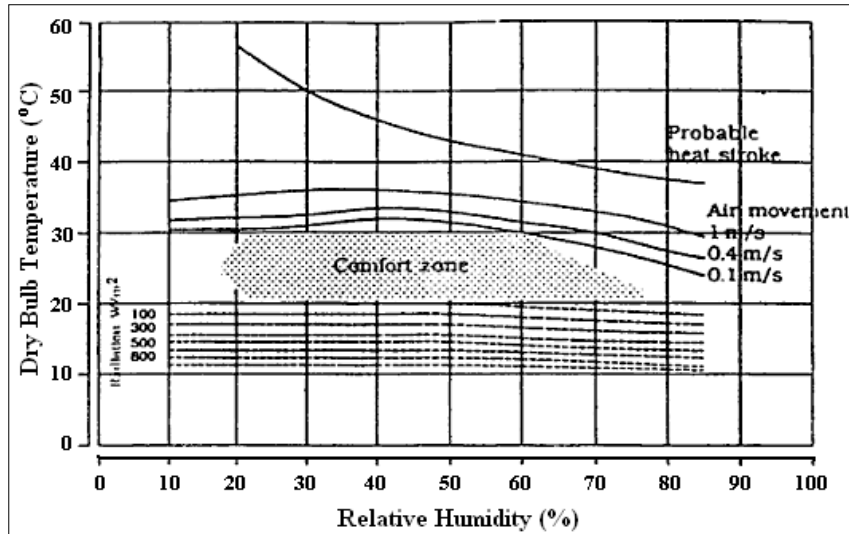

Figure (2.14): Olgay's Bioclimatic Chart
 Source: Azri , Zurigat & Al-Rawahi, (2012)

Another chart is presented by Givoni. Givoni's chart figure (2.15) illustrates the natural ventilation zone which assumes that the outdoor conditions and the indoor mean radiant temperature and the vapor pressure are the same; an assumption that limits the application to buildings with medium to high thermal structure (Azri et al., 2012).

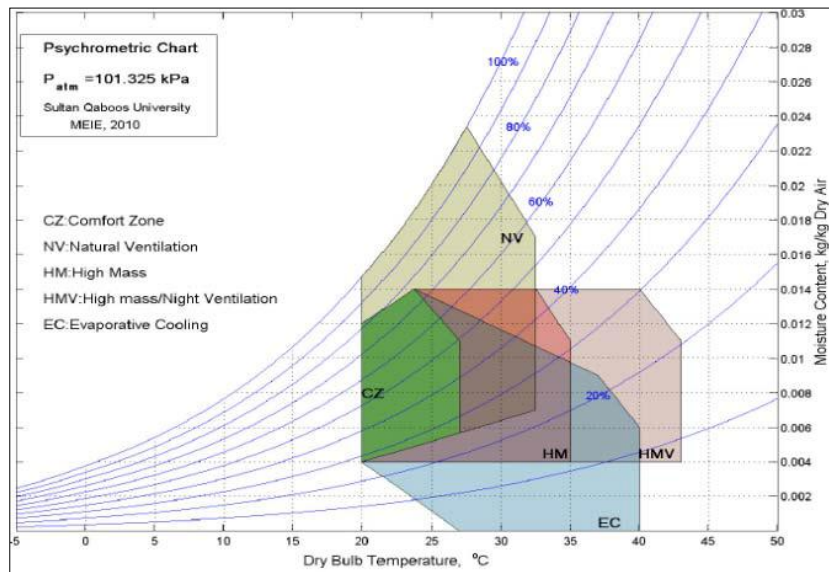

Figure (2.15): Givoni's Bioclimatic Chart
 Source : Azri et al., (2012)

2.4.6 Factors Affecting Thermal Performance of Buildings

Building thermal performance depends on a large number of factors. Generally, the major factors influence the thermal performance of buildings are building form, orientation, shading devices, material properties, natural ventilation and building usage.

1. Building form

The form of the building includes its proportions, volume, configuration, attachment etc. Building form is the most important parameters affecting indoor climate. It is determined by means of the calculated heat loss or heat gain through whole building envelope. Building form can be defined by the shape factor (the ratio of building length to building depth), height and roof type (Oral & Yilmaz,2003), see figure (2.16). On the other hand, the roof form and height has a role in determining indoor thermal conditions, where dome and Cylindrical roofs have a higher heat transfer coefficient than flat roofs of the same base. And the convection heat transfer area is higher for the curved types (Rosenlund, 2000).

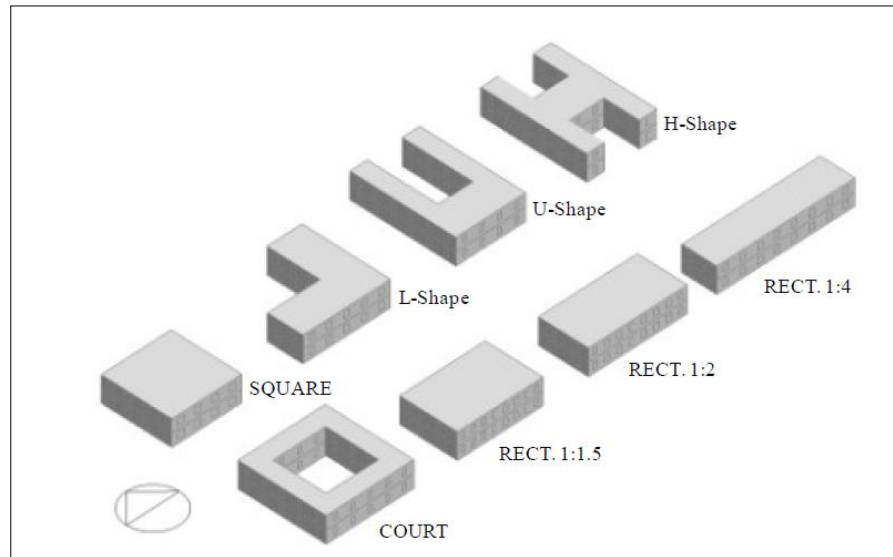

Figure (2.16): Different shapes of building
Source: El-Deeb, El-Zafarany & Sherif, (2012)

2. Building orientation

Selecting the optimal orientation of the building is one of the critical energy efficient design decisions that have effect on energy performance of buildings, as it can be used to reduce the direct sun radiation into the buildings (Al-Tamimi, Fadzil & Harun, 2011). Fadzil and Sia (2004) studied the effect of direct sunlight penetration and daylight distribution in a building with 12 bays of orientation located in a Tropical climate in Penang. The results showed that the best bay with the least sunlight penetration is with orientation 0° as it receives the least heat gain thus reducing the cooling load and saving energy and the worst is with 240° (Fadzil & Sia, 2004), see figure (2.17). Joseph reported a study in (2003) which investigated the effect of building orientation on the direct and

indirect solar radiation intensity. The results indicated that the north has the lowest solar intensity which varies from 43.6 W/m² in October to 65.5 W/ m² in July (Lam & Li, 1999).

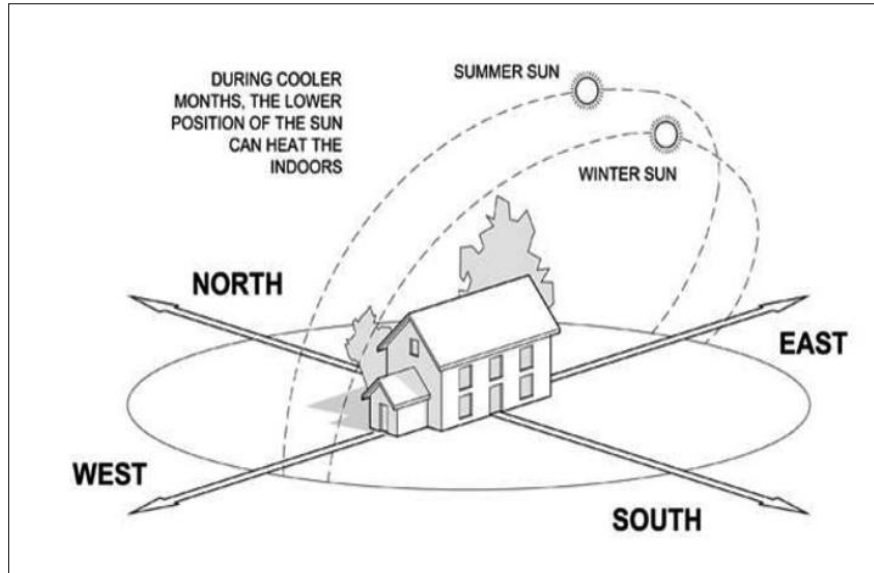

Figure (2.17): The best orientation of the building to solar radiation and wind
Source: Bradshaw, (2006)

3. Shading devices:

Shading devices have a fundamental role in control the amount of solar radiation flowing into the building through openings, windows and large glazed surfaces, especially in semi-desert climates. Datta (2001) studied the effect of using shading devices on thermal performance of buildings in Italy by TRNSYS computer simulation. It found that shading devices could help to save energy and improve the thermal performance of buildings. The optimum design of shading devices can reduce between 23-89% of mechanical cooling loads, depending on climate, site, shading device type, a protrusion of shading device and building orientation (Dubois, 2000). External shading device can give up to 11% energy savings (Kim et al., 2012). Another study looked at the effect of having vertical louvers on the temperature reduction in a residential building in Egypt by using TAS simulation software. The study showed that the louvers worked best at a length of 100 cm, and was effective on the South, West and East elevations resulting in a decrease of 2 degrees (Ahmed, 2012). In a study of Laouadi (2007), it showed that white coloured venetian blinds which are a common type of shading could increase the window luminance by up to 50% as compared with a clear window.

4. Material properties

Material properties of buildings components such as thermal conductivity, thermal resistance, thermal transmittance and density play a key role in controlling the process of heat gain and loss. Thermal conductivity is a property of matter defined as the rate of heat flow (watts) through 1 m² of material at 1m thick even layer of material, maintained under a temperature of 1 degree Kelvin 1°C (CSR Hebel Technical Manual, 2006). The lower value thermal conductivity is the better insulating performance (Mahlia et al., 2007). Thermal resistance is another property of the material, it is the resistance to heat flow between two closed isothermal surfaces at different temperatures (Sofia, 1995). The higher value thermal resistance is the better insulating performance will be (Zotefoams plc, 2007). Another property is thermal transmittance which defined as the rate of heat flow through a unit area of a building (1m²) under a temperature difference of 1 degree Kelvin 1°C (Zotefoams plc, 2007). It is a direct measure of the thermal insulating ability of a given building component air to air (CSR Hebel Technical Manual, 2006). Thermal insulation can effectively reduce the space conditioning loads, so it needs a careful study of its location and thickness (Majumda, 2002). For example, in hot climates, thermal insulation is useful, especially in the roof, which receives the most solar radiation (Rosenlund, 2000). On the other hand, The density plays an essential role for the thermal properties: A heavy elements can store heat (Rosenlund, 2000).

5. Ventilation

Natural ventilation of buildings is a way to improve indoor air quality, thermal comfort in summer and reduce energy consumption. However, efficiency of such a system is highly dependent on climatic conditions (Faggianelli et al., 2014). Natural ventilation defined as the increase in building thermal performance due to an increase in natural air movement as a passive cooling strategy. In a tropical climate the improvements in comfort by natural ventilation range between 9% and 41% (Al-Tamimi, Fadzil & Harun, 2011). Passive ventilation must be taken into account during the design process because there are many architectural features affect air flows through a building, including the building shape, layout of interior walls, floors and furniture (Mikler et al., 2009). According to a guide for designers, developers and owners (1998), there are three common approaches to passive ventilation, see figure (2.18).

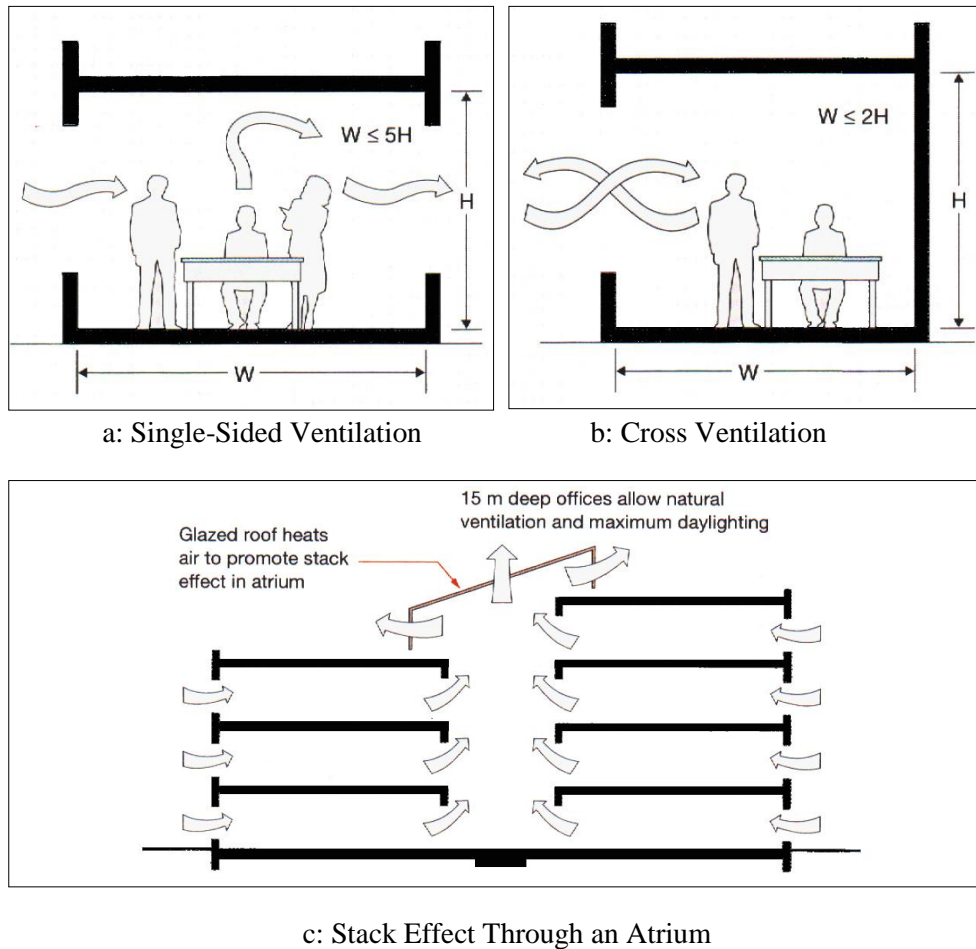

c: Stack Effect Through an Atrium
 Figure (2.18): The three common approaches to passive ventilation
 Source: A guide for designers, developers and owners, (1998)

6. Building usage

Sources of energy input can be considered: occupants, lighting, electrical equipment and solar gain (Johnson, 1981). Buildings usage produces heat from these sources which affect the total heat gain in the building. Santin, Itard and Visscher study (2009) have shown that occupant characteristics and behavior play a great role in the variation in energy consumption in dwellings, it significantly affects energy use (4.2%). On other hand, electric lights give off heat to the building equal to the electrical energy they consume (Utzinger & Wasley, 1997). In addition, air exchanges can contribute significantly in the energy consumption of buildings. Experiments have shown that infiltration heat recovery can reduce the infiltration thermal load by 10–20% (Solupe & Krarti, 2014).

2.5 Conclusion

This chapter addressed the issue of climate conscious urban design and thermal performance of buildings and its relation with energy consumption in the buildings. The conclusion confirmed that the world requirements of energy increases continuously and the dependence is mainly on the fossil resources, which causes environmental pollution problem. However, the energy efficiency and renewable energy are considered perfect alternatives. The chapter outlined the urban design environmental strategies and how to achieve benefits in terms of energy consumption and achieve thermal balance compared to conventional designs. Hence, this chapter highlighted the impact of urban design on comfort outdoors, it concluded that climate responsive design reduces cooling and heating requirements.

Because the thermal performance is considered one of the most important aspect of energy utilization in buildings sector which are considered the large consumer of energy, many factors affecting thermal performance of buildings and energy use are discussed in this chapter including building form, orientation, shading devices, material properties, natural ventilation and building usage. It was concluded that these factors can contribute effectively to reduce the energy consumption.

The conclusion emphasized that both climate conscious urban design and climate responsive buildings design can achieve thermal balance in the internal and external environments. For this purpose the next chapter will displays factors affecting thermal comfort in urban street canyons which have a great impact on solar radiation falling on streets as well as energy consumption in buildings. It will outline the energy, climate, streets and buildings situation in Gaza Strip

Chapter 3: Streets Design and the Situation in the Gaza Strip

3.1 Introduction

Streets are an important element in urban design; they have significant functions beyond those related to vehicular traffic. They are normally lined with buildings and public spaces. Whilst facilitation of movement is still a basic function, they usually support a wide range of social, leisure, retail and commercial functions. Streets have a significant influence on behavior and lifestyles. Also, street design has a direct influence on important issues such as climate change, public health, social justice, inclusivity and economies. This chapter focuses mainly on investigating the design principles of streets which can contribute to reduce the energy consumption.

This chapter introduced an overview of streets and the major components of street design which include width of the street, pattern of the street network and physical elements along the streetscape. Also, it defined a four level road hierarchy which are arterial roads, sub arterial roads, collector streets and local streets. Then, the chapter displayed an overview of thermal comfort of street highlighting factors affecting thermal comfort in urban street canyons which include canyon geometry and orientation, wind flow, use of galleries, canyon asymmetry, overhanging facades and use of vegetation. In addition, the chapter discussed energy, climate, streets and buildings situation in the Gaza strip.

3.2 Definition and components of street

Before going into the details of the factors affecting thermal comfort in streets and therefore the buildings, it is necessary to give an introduction about streets to understand its definition, functions, components and types.

3.2.1 Street definition

According to Ahumphreys (2010), streets are public spaces linking private spaces together in an urban space, they are spaces which people and goods can move through. As public spaces, streets are inclusive spaces. Streets are the place where land use and transportation connect (TGM, 2003).

3.2.2 Urban morphology

Urban morphology is the study of urban form, and an important part of urban design is the creation of urban form. Urban morphology is one of the essential things an urban designer should know about. It is not a formalistic diversion. It is at the root of urbanism and urban design. So, if an understanding of internal structure is essential to successful ‘manipulation’ of a material, urban morphology is essential to urban design (EVANS, 2005).

2.2.3 Principal functions of streets

According to Department for Transport (2007), streets have five principal functions:

- place,
- movement,
- access,
- parking, and
- drainage, utilities and street lighting.

3.2.4 The major components of street design

Good street design is a key element of smart development. TGM (2003) divided the major components of street design as width of the street, pattern of the street network and physical elements along the streetscape.

3.2.4.1 Width of the street

Street width is an important dimension and needs to be considered in relation to function and aesthetics. The variety of activities taking place in the street and of the scale of the buildings on either side should be taken in to account to determine width between buildings, so there are no fixed rules on street width. The distance between interfaces in residential streets typically ranges from 10 m to 18 m, although there are examples of widths significantly less than this working well (Swinney, 2010), see figure (3.1). Strict standards on street widths should be avoided, where seen narrow streets make drivers slower and are thus safer for all street users and increased neighborhood livability (TGM ,2003). However, the typical street standards should be taken in to consideration given to the relationship between scale and the nature of the space created.

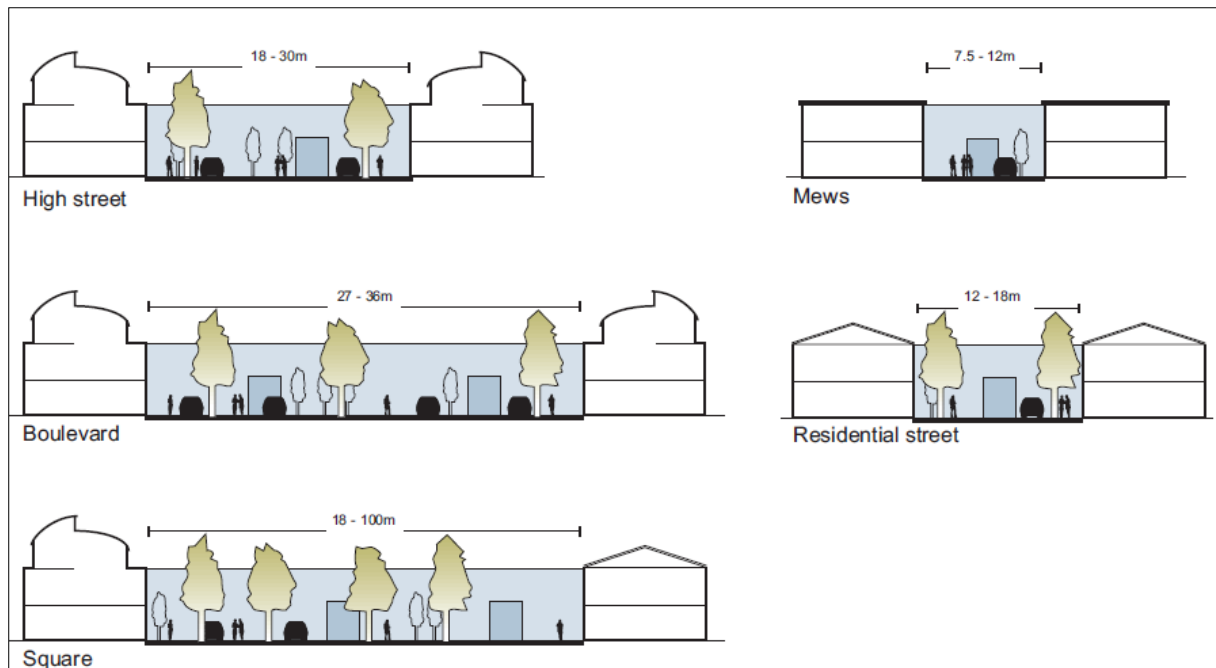

Figure (3.1): Different widths for streets
Source: Swinney, (2010)

3.2.4.2 Pattern of the street network

The structure of a street network can take a variety of forms, from formal grid layouts to more irregular arrangements. Albemarle County (2000) divided these patterns as the rectilinear grid pattern, the diamond grid pattern, the picturesque landscape pattern, the rural village pattern, the curvilinear grid pattern, the star pattern and the stem pattern.

- **The rectilinear grid pattern**

The rectilinear grid pattern is a street system that maximizes connections between places and provides some hierarchy of thoroughfares and regular spacing of junctions (Swinney, 2010), see figure (3.2L).

- **The diamond grid pattern**

The diamond grid pattern is a discontinuous pattern, it can be described as a grid street system characterized by interconnection at angles. Thus, siting of buildings relative to streets can be difficult (Albemarle County, 2000), see figure (3.2R).

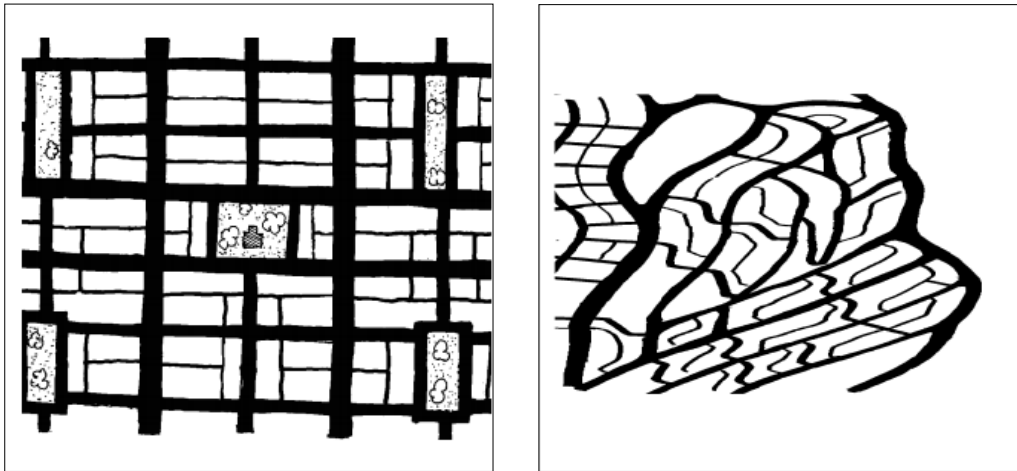

Figure (3.2): L: Example of a rectilinear grid pattern with residential streets, boulevards and parks, R: Example of diamond grid pattern that provides interconnections and responds to steep terrain.

Source: Albemarle County, (2000)

- **The picturesque landscape (olmstedian) pattern**

The picturesque landscape pattern is a bulk and twisted grid has the ability to respond easily to environmental features and terrain, but there is no hierarchy of streets intrinsic to the concept (Olmsted, 2005), see figure (3.3L).

- **The rural village pattern**

The rural village pattern is a series of interconnections that are loosely organized. It is a discontinuous grid street pattern with varying block sizes. Blocks are difficult to design (Albemarle County, 2000), see figure (3.3R).



Figure (3.3): L: Example of picturesque landscape pattern following the terrain and preserving environmentally sensitive areas, R: Example of a rural village pattern showing loosely organized interconnections.

Source: Albemarle County, (2000)

- **The curvilinear grid pattern**

The curvilinear grid pattern aims to promote access to centers or public transport routes (Swinney, 2010). It is more easily adapted to natural factors, but it can result in uphill and downhill houses with asymmetrical streets, see figure (3.4L).

- **The spiderweb or star pattern**

The spiderweb pattern is a grid pattern of streets radiating from a center. It is a geometrically pattern with a central focus. It requires many buildings, particularly at the center, in order to achieve spatial determination (Albemarle County, 2000), see figure (3.4R).

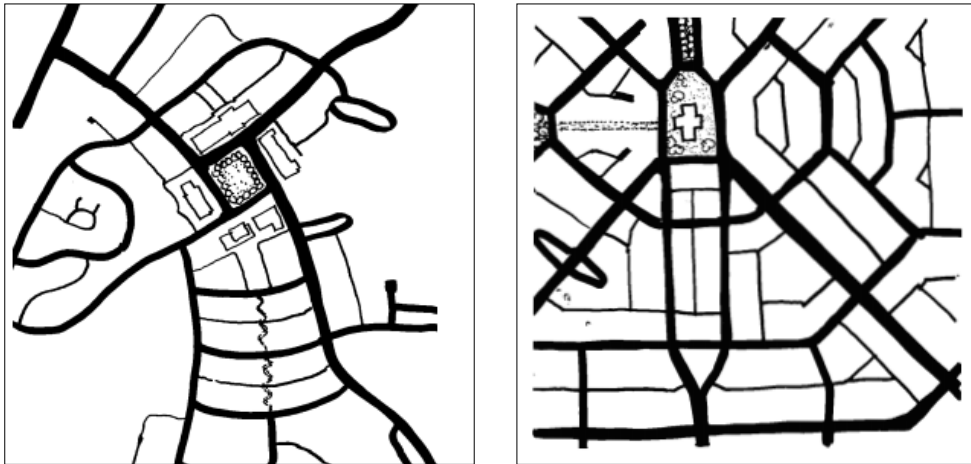

Figure (3.4): L: Example of the curvilinear grid pattern that runs mostly parallel to topography, R: Example of spiderweb pattern that radiates from a center or monument.

Source: Albemarle County, (2000)

- **The stem pattern**

The stem pattern is a series of cul-de-sac streets feeding onto collector streets and arterials. It aims to separate pedestrian paths from vehicular traffic (Albemarle County, 2000), see figure (3.5).

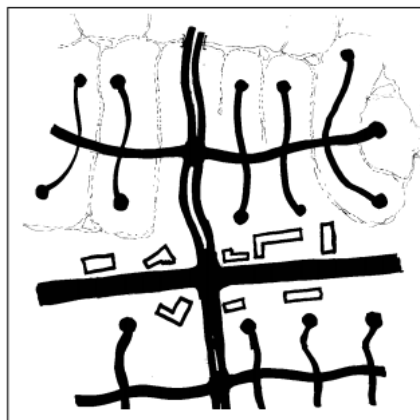

Figure (3.5): Example of the stem pattern of cul-de-sacs, collectors, and arterials.

Source: Albemarle County, (2000)

3.2.4.3 Physical elements along the streetscape.

“Streetscape is a term used to describe the natural and built fabric of the street, and defined as the design quality of the street and its visual effect, particularly how the paved area is laid out and treated. It includes buildings, the street surface, and also the fixtures and fittings that facilitate its use” (Rehan, 2013). Elements of streetscape are main components of streets’ urban design. Rehan (2013) summarized it as follows:

- **Sidewalks**

Sidewalks make up the basic framework of the pedestrian, they are a principal component of most complete streets (GSAP, 2009). Also they should be comprised of an “amenity zone” nearest the curb for trees, plantings and street furnishings (Streetscape Guidelines, 2003), see figures (3.6).

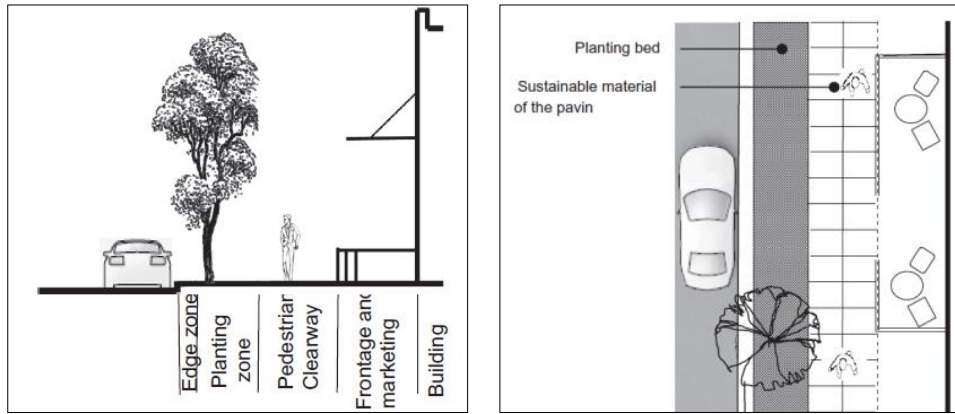

Figure (3.6): L: Cross section of sidewalk, R: Conceptual plan: sidewalk
Source: Rehan, (2013)

- **Street corners**

Street corners give pedestrian way and opportunity for social interaction through the placement of benches and site furnishings such as landscaping, bicycle racks and improved lighting, as well as a safe haven while waiting for crossing the street (Otak Inc., 2007), see figure (3.7).

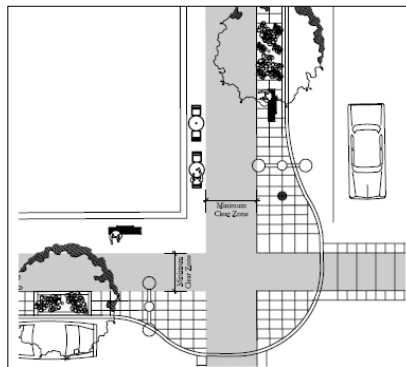

Figure (3.7): Street corners
Source: Otak Inc., (2007)

- **Street trees**

Street trees will act as a trait of the city centre. Urban street trees will balance width of the regional and primary roads. The smaller street trees will make the streets and buildings into human scale (EDA collaborative Inc., 2010).

- **Raingarden**

A raingarden is a green area which aims to address rainwater. As waterfalls onto the garden and passed through a filter media which is planted. Treated stormwater is then left to infiltrate into the ground below (Clearwater, 2012).

- **Street furnishing**

Street furnishings include benches, bicycle facilities, trash receptacles, lighting fixtures, signage, recycling receptacles, newspaper boxes and the like, which are designed to be complementary to the architectural style. Arrangement of street furniture should encourage safe use and enhance the streetscape function and convenience (EDA collaborative Inc., 2010).

- **Lighting**

Street lighting serves a functional and an aesthetic target. Lighting standards should be chosen based on a balanced consideration for maintenance, cost effectiveness, energy efficiency and visual appearance. All lighting devices should be energy saving and provide minimal light emissions to prevent night sky pollution (Rehan, 2013).

Figure (3.8) shows cross section representing the elements of streetscape.

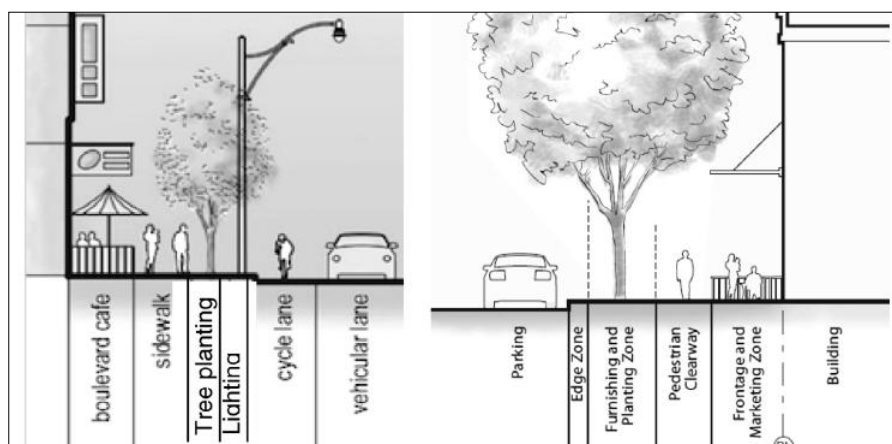

Figure (3.8): The elements of streetscape
Source: Rehan, (2013)

3.2.4.4 A four level road hierarchy

The four functional categories of the hierarchy are defined as:

- **Arterial roads**

Designed to carry through traffic external to the specific area, provides high-capacity connections between urban areas and major centers of activity (Eppell, McClurg & Bunker, 2001).

- **Sub arterial roads**

Designed to carry through traffic between multiple specific areas and the arterial roads. Provides connections between neighborhoods and access to adjoining properties, it aims to promote transit use (Eppell, McClurg & Bunker, 2001).

- **Collector streets**

These streets should not carry traffic external to the specific area. It provides both indirect and direct access for land uses and traffic circulation within all areas. It penetrates neighborhoods and communities collecting and distributing traffic between neighborhoods and the arterial streets (Forbes, n.d.).

- **Local streets**

Designed to low speed environments and to encourage pedestrian circulation. Their function is to provide direct property access, within environmental cells and considerations of comforts (Eppell, McClurg & Bunker, 2001). Figure (3.9) shows a four level road hierarchy for network planning and management.

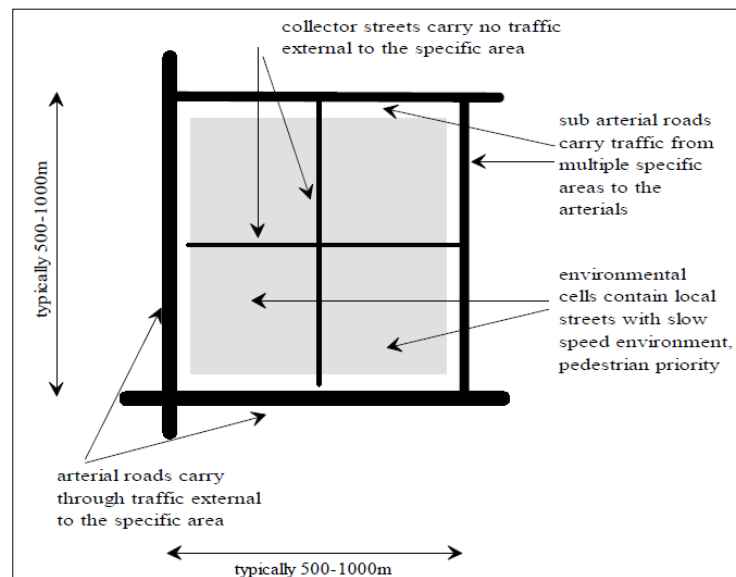

Figure (3.9): A four level road hierarchy for network planning and management.

Source: Eppell, McClurg & Bunker, (2001)

3.3 Thermal comfort of street

The thermal balance of the body is seldom in a steady state due to the different solar radiation received by street area and the human body. Urban street design affects both outdoor and indoor places and therefore affects human thermal comfort either in streets or buildings.

3.3.1 Street design conditions

According to Toudert, (2005) designing a street is primarily conditioned by:

- **Street utility**

Fundamental task of the street in the urban plan, implying scale (width and height), activity, and usage (pedestrian streets or vehicular traffic). This has a direct impact on the period of time at which comfort is essential and also the area of the street where comfort is at most required.

- **Building usage (domestic or non-domestic)**

Domestic buildings are concerned with comfort the day round and require passive solar gains. South, south-east or east exposures of the facades are essential. Non-domestic buildings are interested with comfort during the daytime where day-lighting is the main concern. The potential of natural light depends mainly on sky view, i.e. aspect ratio.

3.3.2 Factors affecting thermal comfort in urban street canyons

Urban design has an effects on thermal comfort in urban street canyons and therefore the buildings. The most important factors affecting thermal comfort in streets which are canyon geometry, wind flow, galleries, asymmetry, overhanging facades and vegetation will be outlined.

- 1. Canyon geometry and orientation**

Geometry and orientation play a major role in identifying a street's climatic features. The street canyon is defined as the area shaped from the buildings of significant height on both sides of a street compared to its width (Papadopoulos, 2001). The dimensions of a street canyon are expressed by its aspect ratio, which is the height (H) of the canyon divided by the width (W). A regular canyon has an aspect ratio of approximately equal to 1. The length (L) of the canyon expresses the road distance between two major intersections, subdividing street canyons into short ($L/H \approx 3$); medium ($L/H \approx 5$) and long

canyons ($L/H \approx 7$) (Vardoulakis et al., 2003). Two parameters are considered in the orientation context, there are the street's axis azimuth and the solar azimuth (Bar & Hoffman, 2003). Toudert & Mayer, (2007) analyzed the dependence of outdoor thermal comfort upon street design under typical summer conditions (1st August) in Ghardaia, Algeria, they studied symmetrical urban canyons with H/W equal to 0.5, 1, 2 and 4 and for different solar orientations (i.e. E-W, N-S, NE-SW and NW-SE), see figure (3.10).

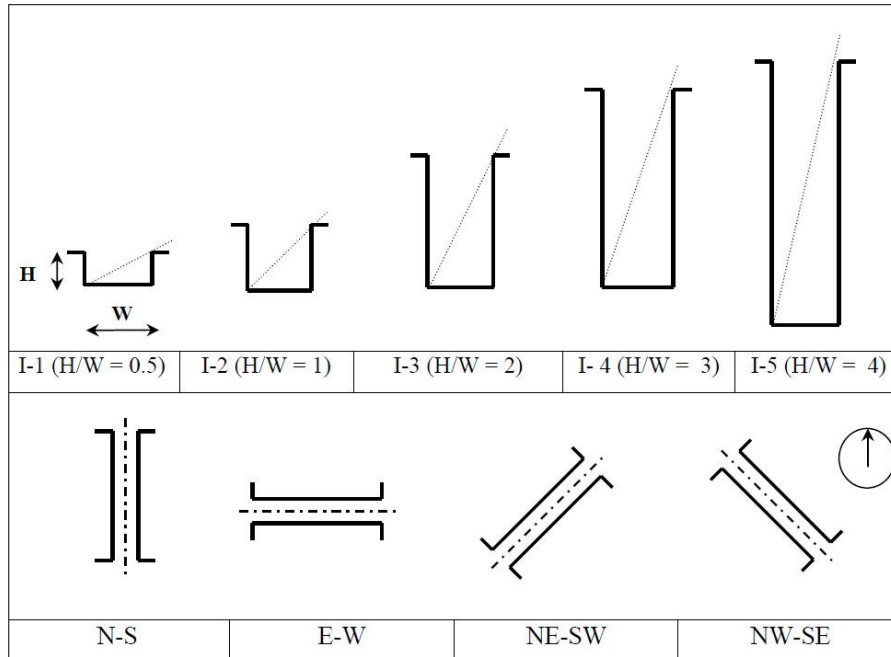

Figure (3.10): Scheme of the urban canyon geometries and the various orientations
Source: Toudert & Mayer, (2007)

The results showed that air temperature T_a decreased moderately with the increase of the aspect ratio, and there are a peak difference of 3 K between the canyons with $H/W = 4$ and 0.5. This means that the shallowest canyon $H/W = 0.5$ is the warmest case study but the deepest canyon $H/W = 4$ is the coolest one, while the differences don't exceed 1 K between two successive canyons (i.e. $H/W = 1$ and 2, 3 and 4). The results for the simulations of PET (Physiologically equivalent temperature) show that the thermal comfort is different between urban street canyons and between the various orientations. Wide streets ($H/W \leq 1$) are uncomfortable for both orientations. Yet, N-S streets have some advantage compared to E-W streets as the thermal situation at their edges along the walls are thermally better for pedestrian.

2. Wind flow

In the street canyon, the wind flow depends on the street orientation and geometry (H: height, L: length, W: width) in relation to three determinants, there are the prevailing wind direction, the canyon geometric characteristics and the temperature conditions on both the street and the surfaces of the buildings (Papadopoulos, 2001). The isolated roughness flow occurs when the buildings are well spaced and the windward and leeward flows don't interact. As the H/W increases and buildings become more closely spaced, the wakes are disturbed resulting in wake interference flow. With further increase of H/W, the street canyon becomes isolated from the above circulating air and a single vortex is formed within the canyon, leading to a skimming flow (vardoulakis et al., 2003), see figure (3.11).

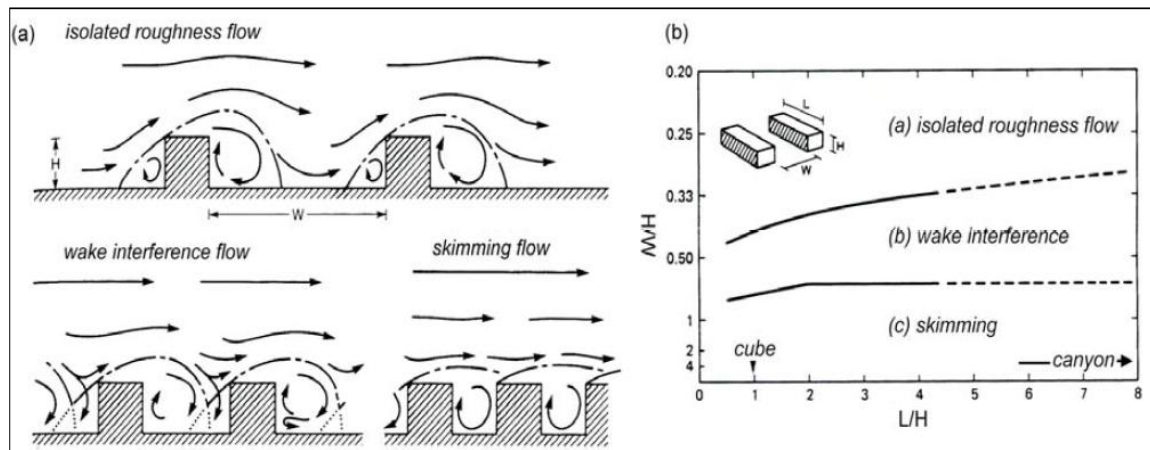

Figure (3.11): (a) Wind flow regimes and (b) corresponding threshold lines dividing flow into three regimes as function of canyon (H/W) and building (L/W) geometry

Source: Toudert, (2005)

In case of light winds, the air canyon flow include a mechanically driven circulation and thermal effects due to canyon facets irradiation which play a great role on the air flow distribution in canyons. In the day period, differences in air temperature between the two building facades, up to 4.5°C, were noted mainly due to the impact of the surface temperature. Comparing the air temperature distribution in the heavy traffic canyon, with a nearby pedestrian street, with the same orientation and aspect ratio the traffic canyon was always warmer by about 2°C, referring to the influence of the traffic on the canyon thermal balance (Santamouris et al. 1999). On the other hand, the temperature cross-section suggests the formation of a one vortex exchanging warm air in canyon space with cool air above the roof and expelling hot air. In addition, the difference in temperatures in street

surfaces can shift the flow from one system to another and from a one vortex flow to a flow with several vortices (Sini et al., 1996). A double vortex is always noted, together with temperature layers and hence higher ambient winds contribute to the transmission of more energy from the upper to the lower vortex and therefore increase its speed. Furthermore, a wider canyon enhances better mixing of air and canyon geometry should be limited to minimum value for skimming flow and maximum relative canyon length ratio L/H should be kept at five (Chan, So & Samad, 2001).

3. Use of galleries

Using galleries as a shading device is already known from the Greek portico in ancient time (Toudert & Mayer, 2007). Colonnades are suitable in hot climate, they are commonly used in traditional and contemporary designs (Swaid, Bar-El & Hoffman, 1993). The thermal situation in the galleries area is better than irradiation locations in the street and more useful for mitigating thermal stress (Toudert, 2005). This is because the reduced solar radiation received by a person and to less long-wave irradiation emitted by the adjacent surfaces, especially the ground. However, these galleries can also face short discomfort periods, in form of an extension of the extreme thermal stress zone when noted at the sidewalks because the direct solar radiation on the pedestrian and the ground surface. This depends on the gallery dimensions and the street orientation. Toudert and Mayer (2007) studied urban streets of $H/W = 2$ including galleries for various street orientations. The gallery is 4 m high and 3 m wide, see figure (3.12). The results showed that the galleries of an E-W street are best protected and the period of discomfort is limited.

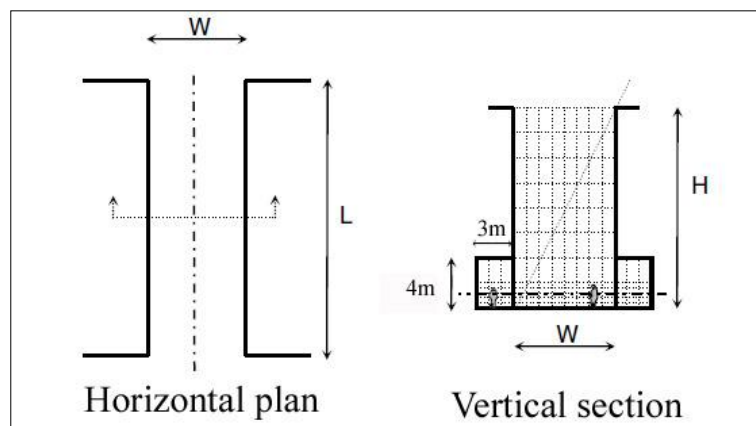

Figure (3.12): Scheme of the gallery
Source: Toudert & Mayer, (2007)

4. Canyon asymmetry

This is a design alternative which is opposite to the covered areas design. Asymmetrical morphology includes a wide opening to the sky. Asymmetric street design which has a greater sky view aims to maintain adequate solar access in the winter and encourages a good cooling at night (Toudert & Mayer, 2007), see figure (3.13).

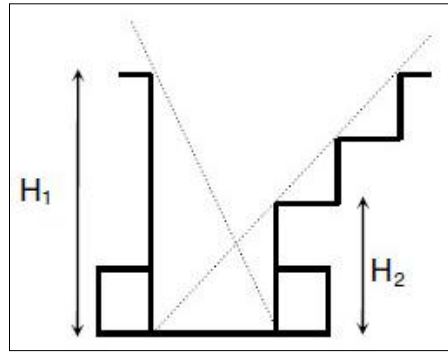

Figure (3.13): an asymmetrical urban canyon with a wide opening to the sky
Source: Toudert & Mayer, (2007)

The importance of the canyon asymmetry has been pointed out by the solar urban architecture for optimizing internal solar gains (Pereira, Silva & Turkienikz, 2001). Because asymmetrical street geometries leads to more solar exposure of the street in the summer, galleries as a shading device can be added to protect pedestrian spaces. Toudert, (2005) showed that asymmetrical morphology is more stressful than a regular street. However, asymmetrical profile can lead to a better thermal situation especially in the early morning when the sunlight coming laterally from the sides are prevented by the higher facades. Toudert and Mayer (2007) observed in an asymmetrical urban canyon with galleries that the effectiveness of the galleries is reduced if the aspect ratio decreases and the extension of the discomfort within the covered areas becomes longer depending on the orientation.

5. Overhanging facades

Street morphology includes a small opening to the sky, see figure (3.14). In the winter, the exposure of the walls to the sun is larger, but the street level is more shaded in summer due to the offset of the facades over it. Balconies or inclined facades can be used as horizontal shading devices and reduce the heat stress. On the other hand, more internal solar access is ensured in winter (Toudert & Mayer, 2007). Also, maximal values of PET slightly decrease. This is advisable design solution if combined with an asymmetrical

design. Moreover, these “self-shading” facades reduce the high temperature of interior environments by less warming of their surfaces and thus less heat conduction towards indoors spaces (Toudert, 2005).

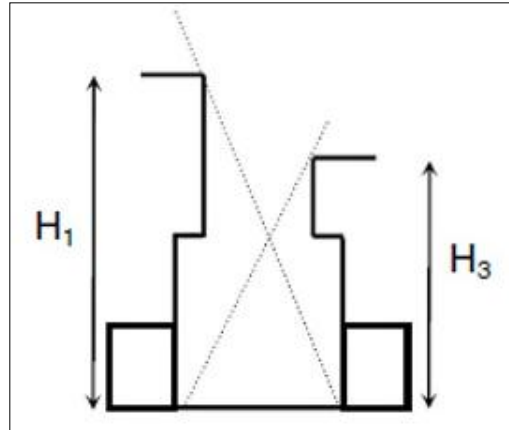

Figure (3.14): an asymmetrical urban canyon with overhanging facades and galleries
Source: Toudert & Mayer, (2007)

Toudert and Mayer (2007) found that the period of highest discomfort in this design is lower for all four orientations when compared to a symmetrical profile of higher aspect ratio, but overhanging facades are most efficient for NW–SE streets and less for NE–SW streets. And intermediate orientations show an appreciable amelioration in the thermal comfort situation in summer.

6. Use of vegetation

The use of vegetation is an ideal solution for reducing heat stress at street level (Avissar, 1996). Planting trees is suited when the building facades don't operate as a good shading device for the street space because of an inappropriate aspect ratio or an improper street orientation (Toudert, 2005). Toudert and Mayer (2007) noted that the use of a row of trees improves the thermal situation within street area, because the direct solar radiation is strongly decreased under trees. So, shading is the significant feature of the planting that leads to heat stress mitigation (Bar & Hoffmann, 2003). However, the vegetation has three main properties can affect the climate which are shading, humidification and windbreak. McPherson, Nowak and Rowntree (1994) observed that major economies in Chicago gained from green area, from which one-third consisting in alignment of trees in urban streets. So, the usefulness of the rows along the streets shouldn't be underestimated. Bar

and Hoffman (2000) investigated the cooling effects of trees at courtyards, streets and small urban green sites in a subtropical location. They found for several planted streets that the cooling effect is about 1 K and up to 3 K at the hottest hour of the day. The highest effects are recorded at the centre of the canyon but the cooling effect reduces when moving to the edges of street. According to Toudert (2005), the shading effect can be easily evaluated for a single tree but the cooling by evapotranspiration is difficult to estimate. On the other hand, evapotranspiration effects and wind speed reduction are easily estimated for aggregated trees. For example, in a residential area, the cooling effect largely provided with trees can experience 50% less wind speed and (up to 5 K) lower air temperatures.

3.4 Energy, climate, streets and buildings situation in Gaza Strip

In light of the political context in the Gaza Strip, sustainable energy can play a key role in guaranteeing energy conservation in the long-term. Urban street plan and the architectural buildings are important component of human civilization in the Gaza strip, however they consume a large amount of energy as a result of technological development in order to achieve thermal comfort to their occupants. It is important to view some facts in the Gaza strip about energy, climate, streets, buildings and their environmental impacts.

3.4.1 The Gaza Strip in brief

As shown in figure (3.15) the Gaza Strip is a narrow strip of land extends along the Eastern Mediterranean beach with a length of 40 km and a width ranges between 6 km in the north and 12 km in the south (ARIJ, 2003). It has a total area of about 365 km² (Bashitialshaaer, 2011) and a population of 1.87 million with a growth rate of 2.91% (Index mundi, 2014). It is located on Longitude 34° 26' east and Latitude 31° 10' north (Ministry of Local Government, 2004). According to the Koppen system for climatic zoning, winter in the Gaza Strip area is rainy and mild while summer is hot and dry. Gaza Strip area is surrounded by the Negev desert, Occupied Palestinian lands, Egypt and the Mediterranean Sea.

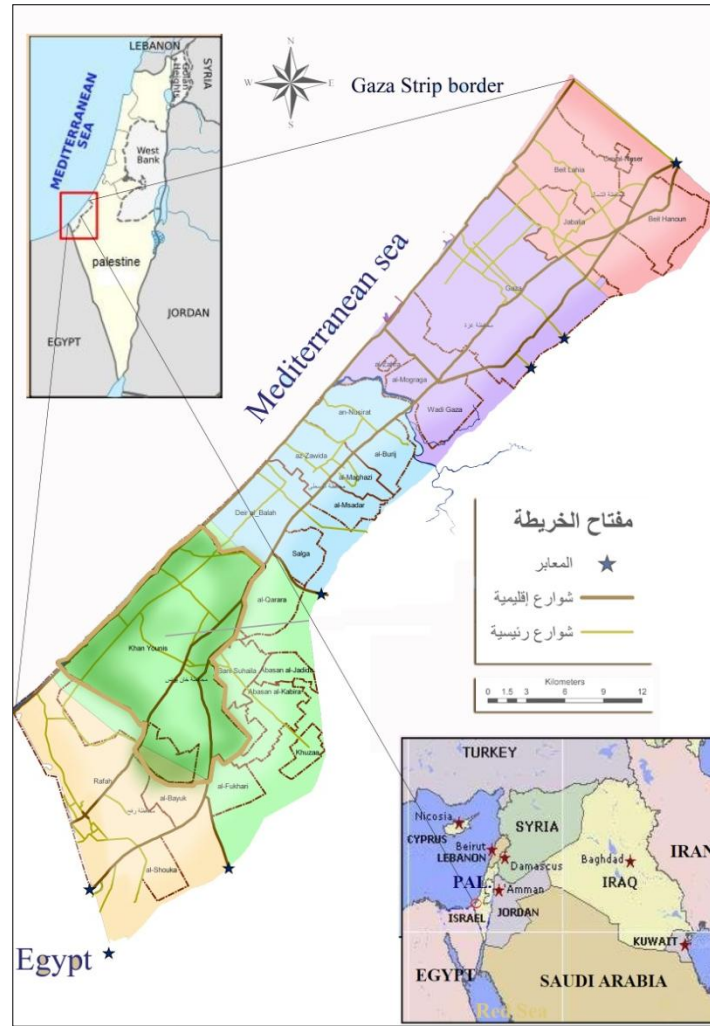

Figure (3.15): Gaza Strip map
Source: Khan Younis Municipality - adapted

3.4.2 Energy situation in the Gaza Strip

Palestinian energy sector is unable to exploit its available resources, causing it to largely depend on the electricity and fossil fuel imported from the occupied Palestinian lands (Israel). It is clear that using fossil fuel to produce energy has harmful impacts on human health due to emission of greenhouse gases. So, there is a tendency to improve energy efficiency in buildings and reduce the dependence on conventional types of energy with exploitation of renewable energy resources.

3.4.2.1 Energy shortage in the Gaza Strip

There is a clear lack in electricity supply to the Gaza Strip, the electricity energy has been aggravation since 2007 because of the economic siege imposed on the Strip (Musalam, 2013). Statistics show that the Gaza Strip needs 500 MW of electricity. In

reality, the Strip receives only 152 MW. The Israeli Electricity Company provides 120 MW, Egypt provides 32 MW which allocated to Rafah province according to electricity technical nature, Egypt only provides half of Rafah needs. On the other hand, the Gaza Power Plant does not provide anything (after the last war at 2014). But when repaired, it will provide 60 MW. Therefore, the Gaza Strip shortage of electricity is about 70% (Electricity distribution company for Gaza provinces, 2014). Israel Electrical Company reduced its supply in 2008 which increased the pressure on Gaza electricity distribution company (Droege, 2009). Figure (3.16) shows the shortage of electricity is about 70% without taking into account the Gaza power plant supplies.



Figure (3.16): Power Deficit – Gaza Strip
Source: Electricity distribution company for Gaza provinces, (2014)

3.4.2.2 Residential building and energy use

Generally in Palestine, the residential sector is the main sector that consumed the energy as depicted in figure (3.17). In 2005 the percentage of energy imports for the residential sector was 64% in the whole of Palestine, transportation sector was 19%. While the industrial sector was 8% (Abu-Hafeetha, 2009). In the Gaza Strip, residential buildings are the largest consumer of energy that exceeded 70% of the total energy consumed (PENRA, 2014).

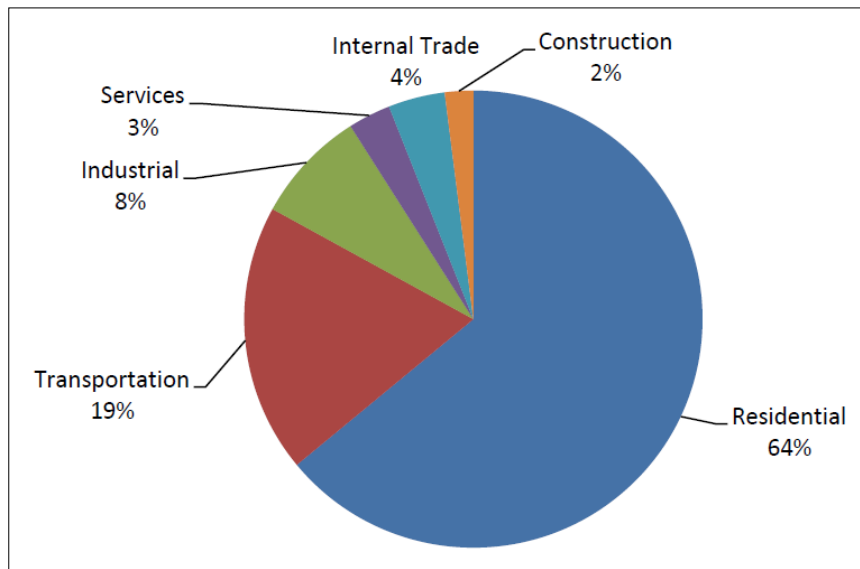

Figure (3.17): The Percentage Imports of energy's derivatives by Sectors in 2005
Source: Abu-Hafeetha, (2009)

3.4.2.3 Renewable energy potential in the Gaza Strip

Renewable energy is extremely important for Gaza Strip, both for energy security reasons as well as for improving economic conditions. The main renewable energy sources in Palestine are solar, wind, biomass and geothermal. Using these energy sources may significantly decrease the energy reliance on neighboring countries.

1- Solar energy

There is high potential for solar energy in the Gaza Strip, it receives about 3000 hours of sunshine per year with a daily average solar radiation of 5.4 kWh/m² (Mahmoud & Ibrik, 2003). This high values encourage the use of solar energy for various fields such as water heating, drying of crops, water desalination, water pumping and provision of electrical networks in remote areas (Ibrik, 2009).

Gaza Strip is one of the leading cities worldwide in usage of solar water heaters for domestic applications, According to Muhaisen (2007), about 67% of residential buildings in the Gaza strip use solar water heaters. In addition, Rooftop photovoltaic installations has a role in providing electricity to the grid. Only 10% of the rooftop area using for photovoltaic installation would generated around 146 GWh per year (Hamed, Flamm & Ismail, 2012).

2- Wind energy

According to Hamed, Flamm and Ismail (2012), the most important factors that have to be taken into account when designing a wind farm are the long-term wind velocity measurements, the energy of the wind, the generator type and the results of the feasibility study. In Palestine, a wind farm of 50 turbines, each would generate 355 GWh/year could provided 6.6% of the electricity need (Abu Hamed, Flamm & Azraq, 2011). In the Gaza strip, the potential for using wind energy is low due to lower wind speed; lack of open lands; obstruction of equipment and material transport from Israel to Gaza and the difficulty in setting up offshore wind farms because of Israel's siege (Abu Hamed, Flamm & Azraq, 2011). However, the low speed winds may encourage using wind energy in independent systems to provide small electricity loads, such as for water pumping, grain grinding and small residential wind turbines.

3- Biomass

Biomass is considered a strategic energy resource, because it keeps the environment and since it is a source of fuel for vehicles. It includes both traditional uses for cooking and heating and modern uses includes straw, animal dung, vegetable oil, biodiesel and biogas (Bilen et al., 2008). At the present time, biomass energy contributes approximately 14% of Palestinian energy supply (Hamed, Flamm & Ismail, 2012). Gaza Strip has a great potential for biomass energy. People in rural areas may take advantages from producing biomass energy in different forms, including wood, crop residues and biogas. Abu Hamed et al., (2011) studied the potential energy production from the agricultural waste in Palestine. The result showed that about 22,800 tons of biodiesel can be produced through a biomass-to-liquid converting process, which represent about 5% of the national diesel consumption.

4- Geothermal

Geothermal energy is the exploitation of heat inside the earth for heating and electricity generation (Bilen, 2008). Although geothermal energy potential in the Gaza strip is a little compared to other renewable sources, yet it has good potential for heating and cooling. Geothermal energy system uses the stable temperature inside the earth at a specific depth for heating in cold days, cooling in hot days and reducing energy consumption (Hamed, Flamm & Ismail, 2012). Geothermal Energy may be used for cooling applications in Gaza Strip, use the closed- loop is the best method by digging vertical holes in the ground, since the land of the Gaza strip is limited (Yaseen, 2012).

3.4.3 Climate conditions in the Gaza Strip

The Gaza Strip is considered a transitional zone between the semi-humid coastal area in the north and the semi-arid Sinai desert in the south (ARIJ, 2003). The Gaza Strip receives a variable amount of solar radiation during the day and throughout the year, this is responsible for the variations in the average daily mean temperature which ranges from 25C° in the summer season (May-August) to 13C° in the winter season (November-February) (Ministry of local government, 2004), see figure (3.18).

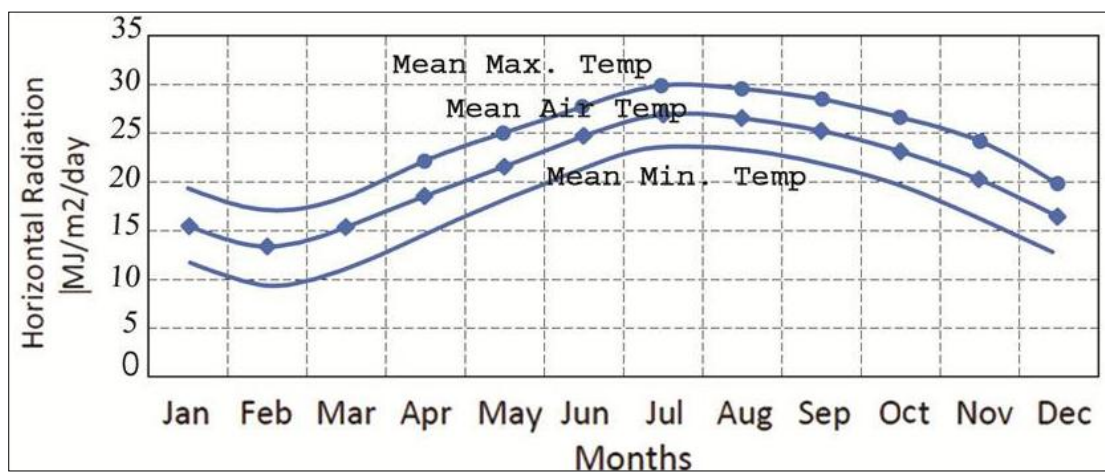

Figure (3.18): The annual variation in solar radiation (MJ/m2/day) in Gaza Strip Source: Source: Ministry of local government, (2004)

Prevailing winds in the Gaza Strip are northern western wind. Its speed reaches 3.9 m/s during the afternoon of summer months, In the winter the prevailing wind direction turns to southern western and its speed increases up to 4.2 m/s, and sometimes winds blows up to 18 m/s, (Ministry of local government, 2004), show figure (3.19).

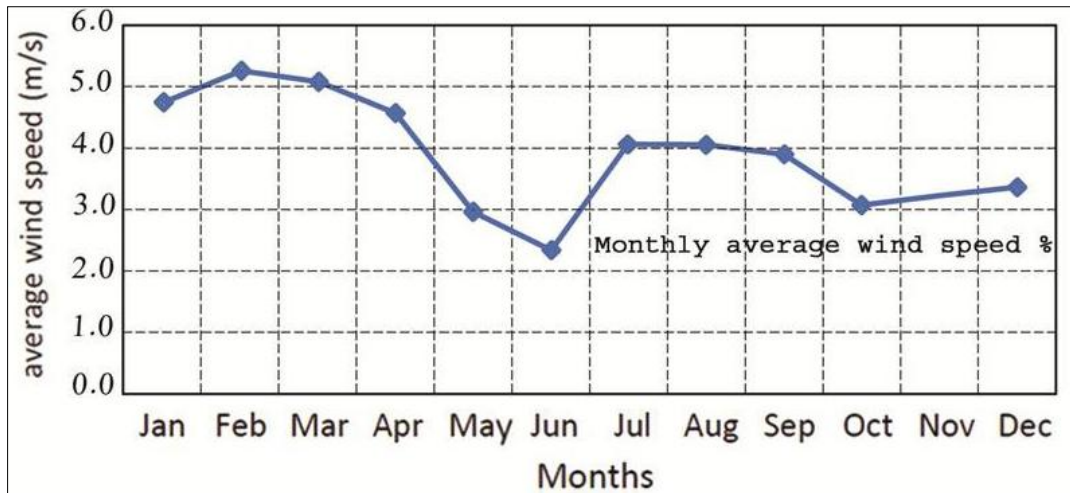

Figure (3.19): The annual average wind speed (m/s) in Gaza Strip
 Source: Ministry of local government, (2004)

Also, relative humidity fluctuates between 65% in day and 85% at night in the summer, and between 60% and 80% in winter. Figure (3.20) shows the annual average relative humidity in the Gaza Strip (Ministry of Local Government, 2004).

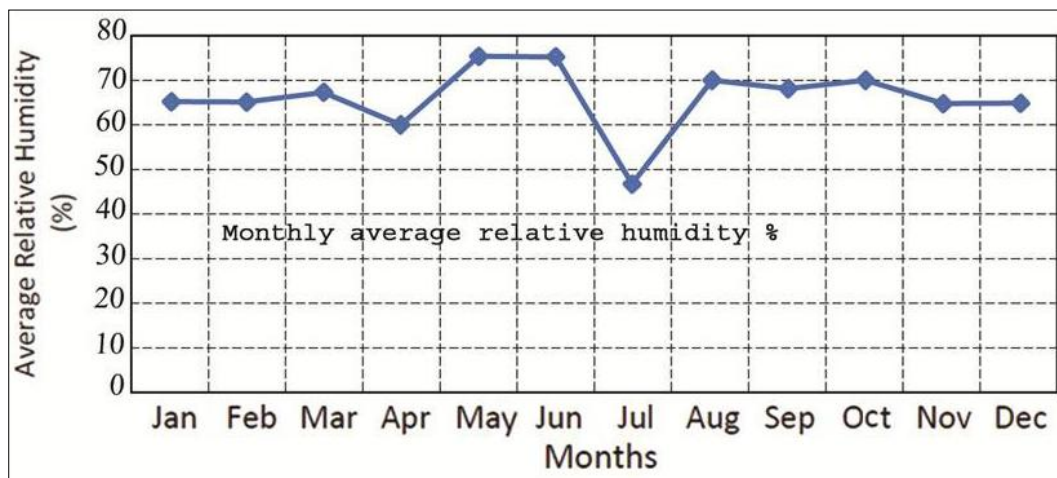

Figure (3.20): The annual average Relative Humidity in Gaza Strip
 Source: Ministry of local government, (2004)

3.4.4 Streets situation in the Gaza Strip

Generally, streets in the Gaza strip are parallel to (NE- SW) and perpendicular to (NW- SE) orientations to the Mediterranean sea coast. Therefore, plots of land and buildings take this orientations which usually does not take the climatic factors into consideration, see figure (3.21).

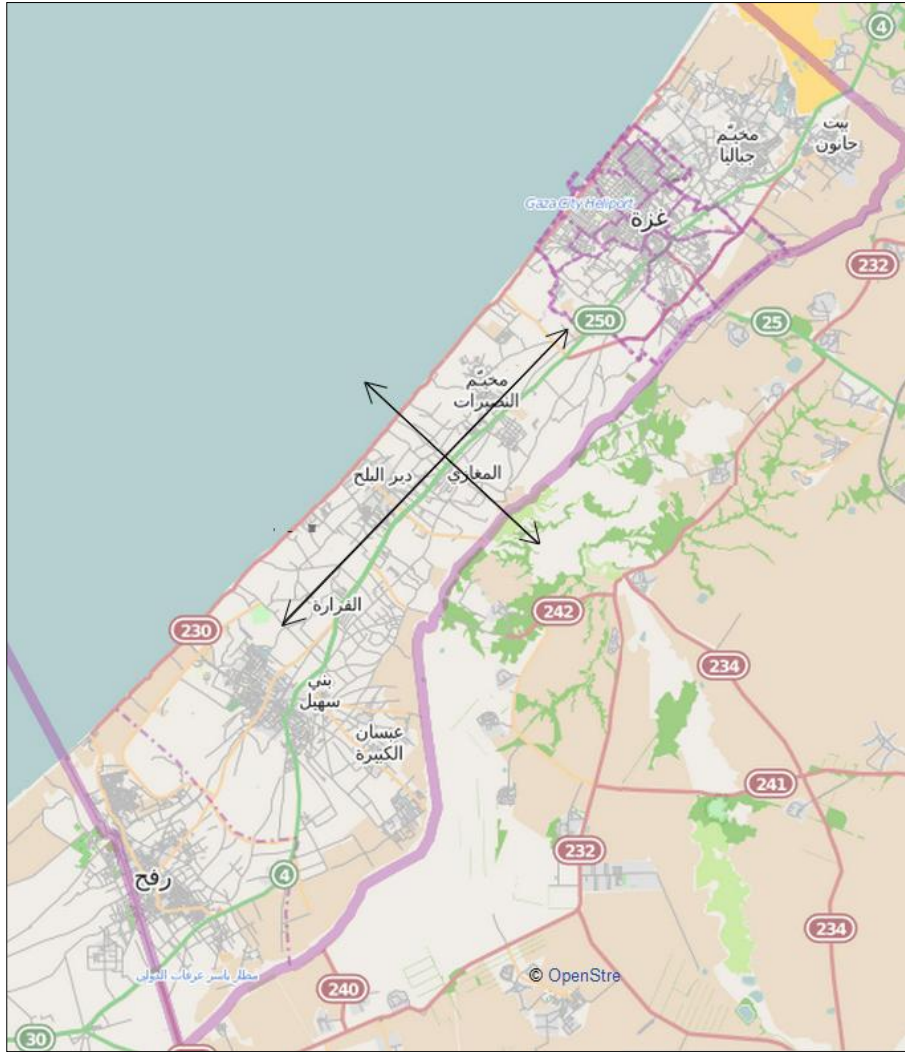

Figure (3.21): streets and parcel's orientation in the Gaza strip
Source: Open street map, (2011)

As the Gaza city is considered the main city in the Gaza Strip, special attention must be considered. Therefore, the most important streets which penetrate the Gaza city will be clarified (Ministry of Local Government), see figure (3.22).

1- Regional roads:

Gaza city is linked with other cities by two major regional roads which can be described as follows:

Street No. 4: is the main highway of the Gaza Strip, it extends from BeitHanoun crossing in the north to Rafah crossing in the south going through the east of Gaza City under the name of Al-Karama Street. The street is 53 meters wide.

Al-Rashid Street (the coastal road): extends parallel to the Mediterranean coast and connects the Gaza Strip cities from north to south. The street is 40 m wide.

2- The main streets:

They branch from the regional roads to serve the cities and residential areas that are located on both sides of the regional roads, the width of these streets ranges from 12 to 34 m. There are two types of main streets:

The first: connects Gaza City with other cities within the Gaza Strip such as Salah Al-Din Street and Al-Jalaa street which links the Gaza city with Jabalya city. Also, Netsarim street, which connects Gaza City with Al-Zahra, Al-Moghraqa and township of Gaza valley (Juhor Al- deek). In addition, Al-Nasr Street, which links Gaza city with BeitLahiya city.

The second: connects the Gaza City neighborhoods with each other such as Omar Al-Mukhtar Street, Al-Wehda street, Al-Thalathini street, No. 8 streets, Al-Quds street, Al-Aqsa street and Al-Shifa street, etc.

3- Collector streets:

Usually used to collect and distribute the traffic from and to the local streets, like Kamal Nasser street, Omar bin al-Khattab street, Salah Khalaf street and Palestine Street, etc. The width of these streets range from 12 to 22 m.

4- local streets:

Streets connecting between neighborhoods, local services and collector streets. Traffic volume is low and traffic speed is constrained. The width of these streets range from 8 to 12m.

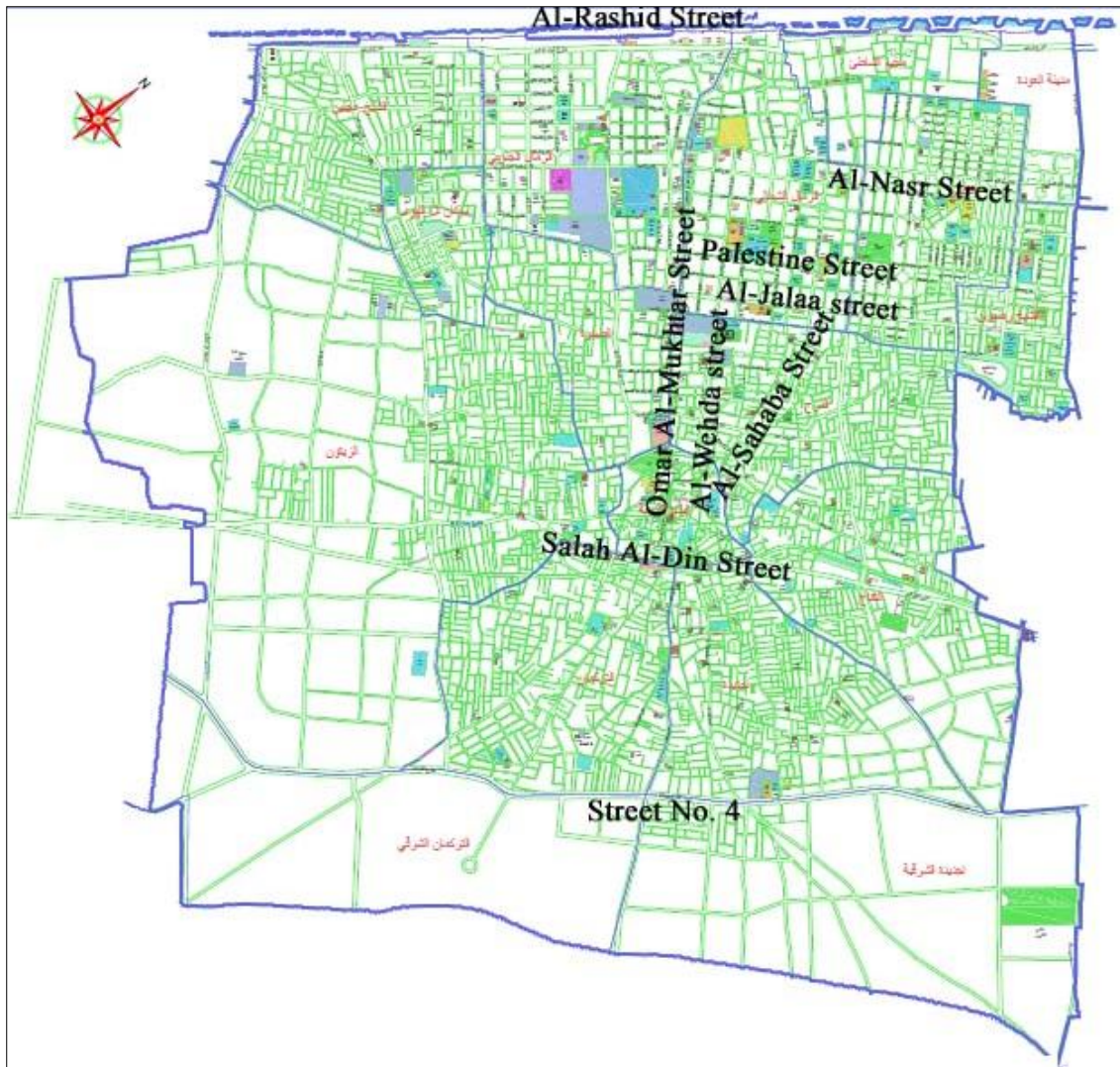
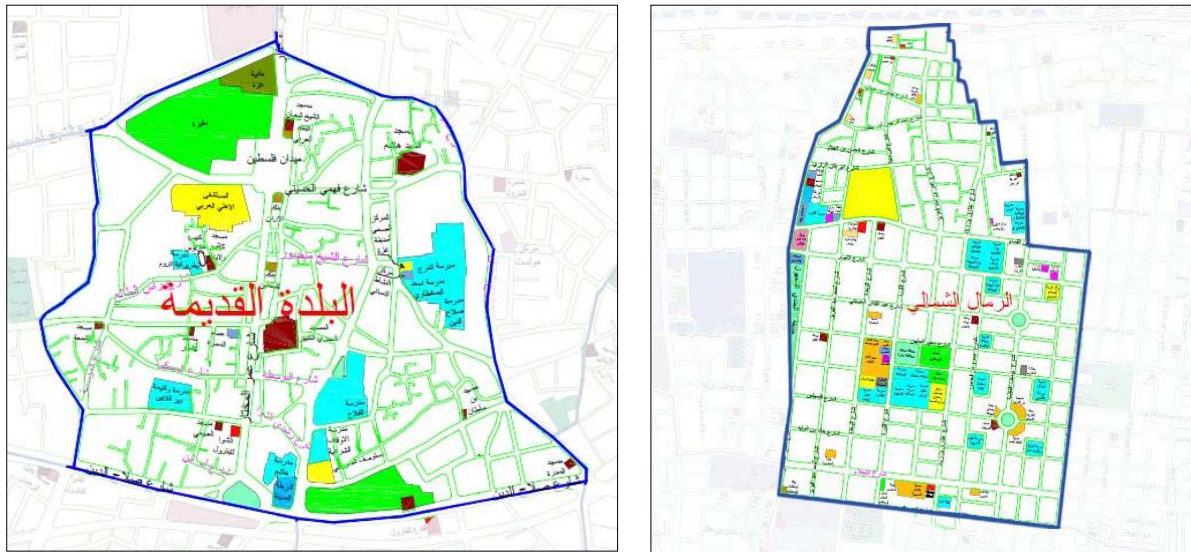

Figure (3.22): Plan for Gaza City shows the streets names
Source: Ministry of Local Government

- **Morphology of streets in the Gaza city**

In the Gaza city, urban fabric differs from an area to other, thus variety of planning models for streets appeared in the Gaza city. For example, some streets that follow a rectilinear grid pattern appeared in areas which produced by the British Mandate and the Egyptian administration in the period between 1917 and 1967, these areas are a northwestern areas of Gaza City, such as Al-Naser, the Sheikh Radwan, Al-Remal and Tel al-Hawa (the new Gaza). Other streets that follow a curvilinear grid pattern appeared in old areas of the Gaza city such as the old town in the center of Gaza City. Also, separated curved streets appeared in some area as Al- Istiklal Street in Al-daraj area. In addition,

there are streets follow a stem (branches) pattern in the old town of the Gaza city, east of Gaza city and unorganized regions (non-contingent), see figure (3.23).



a: old town plan , b: plan for northern Remal area

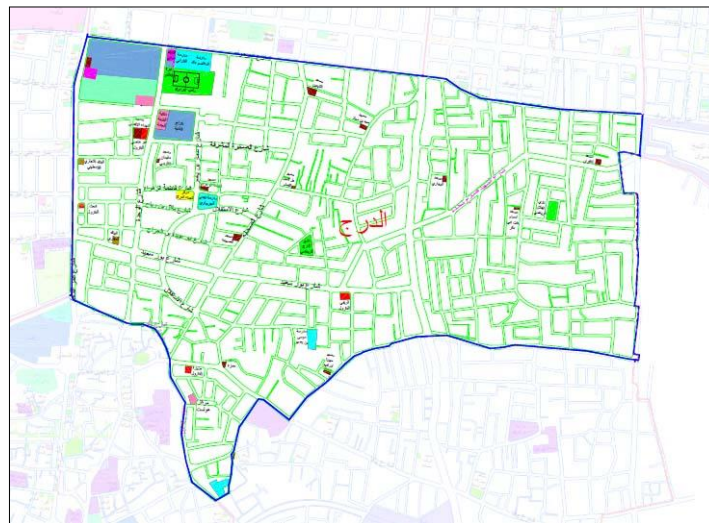

c: plan for Al-Daraj area

Figure (3.23): a: plan for Al-Daraj area
Source: Ministry of Local Government

According to the objectives of this study, different points were selected in 26 locations with various orientations, shape and aspect ratios in order to identify the morphology of the streets in the Gaza city, these points were arranged to pass the different types of streets in the city. It passes Omar Al-Mukhtar Street which is considered the main street in Gaza City and Palestine street which is collector street. Also, it passes old town street which is local street. The H/W ratios of the selected streets vary between 0.16 and 5.7 and the

orientation (angle from N) varies between 39° and 167°. To get a better impression of the site conditions, see figure (3.24) and table (3.1). Figure (3.25) shows photos of selected sites.

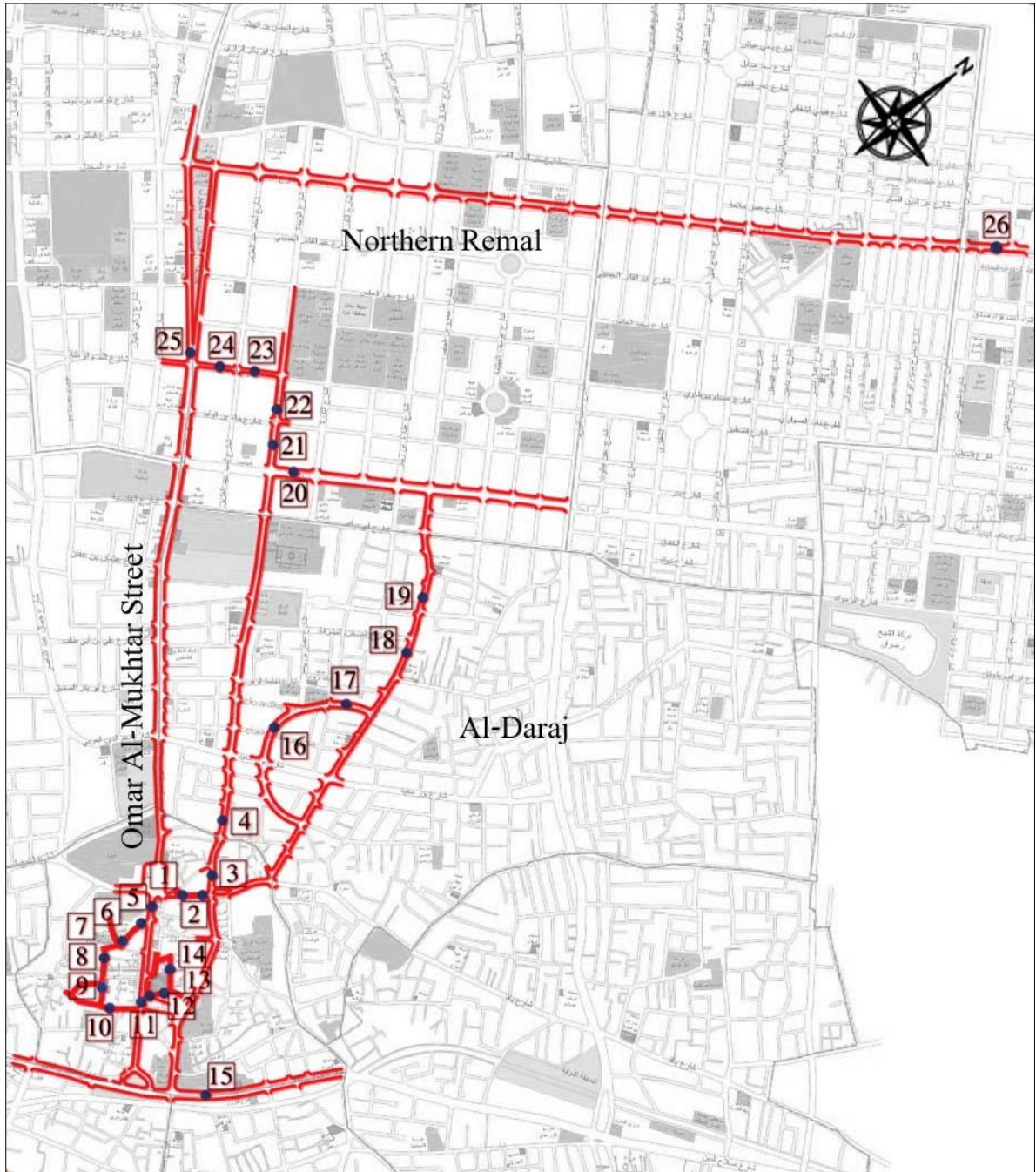
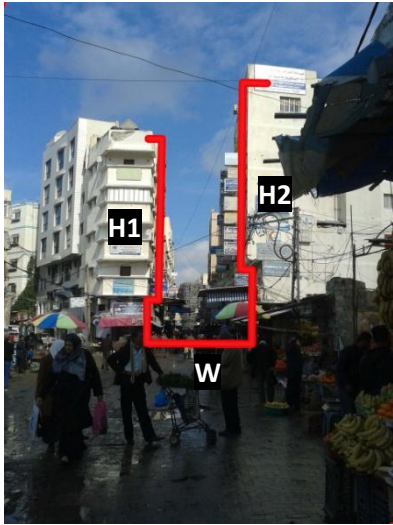

Figure (3.24): Route and all selected points within different street geometries in Gaza City
Source: Ministry of Local Government (adapted by author)

Table (3.1): Street properties at the twenty six different points in the Gaza city

site	Name	Category	aspect ratio H/W	orientation (angle from N)	Street shape	Shading methods
1	Fahmy beik Al- husseini street	Local street	H1/W = 1.9; H2/W = 2.2; H2/ H1= 1.15	NE-SW; 39°	Straight	regular overhanging facades & asymmetry
2	Fahmy beik Al- husseini street	Local street	H1/W = 1.6; H2/W = 1.3; H2/ H1= 0.8	NE-SW; 39°	Straight	regular overhanging facades, asymmetry & fabric cover
3	Al- Wehda streets	main street-sec	H1/W = 0.53; H2/W = 0.9; H2/H1= 1.7	NW-SE; 132°	Straight	gradual and regular overhanging facades
4	Al- Wehda streets	main street-sec	H1/W = 0.6; H2/W = 1.2; H2/H1= 2.0	NW-SE; 133°	Straight	regular overhanging facades & asymmetry
5	Omar Al- Mukhtar Street	main street-sec	H1/W = 0.48; H2/W = 1.15; H2/H1= 2.4	NW-SE; 135°	Straight	regular overhanging facades & asymmetry
6	old town streets (a)	Local street	H1/W = 1.8; H2/W = 1.8; H2/H1= 1.0	NE-SW; 54°	Plover	gradual and regular overhanging facades
7	old town streets (b)	Local street	H1/W = 0.7; H2/W = 1.15; H2/H1= 1.6	NE-SW;; 63°	Plover	Balconies
8	old town streets (c)	Local street	H1/W = 3.0; H2/W = 3.8; H2/H1= 1.2	NW-SE; 120°	Plover	Deep canyon & asymmetry
9	old town streets (d)	Local street	H1/W = 5.7; H2/W = 5.7; H2/H1= 1.0	NW-SE; 141°	Plover	Deep canyon, regular overhanging facades & asymmetry
10	Al- mahkma street	Collector street	H1/W = 2.3; H2/W = 1.9; H2/H1= 0.8	NE-SW; 38°	Straight	Deep canyon & regular overhanging facades
11	Omar Al- Mukhtar Street	main street-sec	H1/W = 1.2; H2/W = 0.7; H2/H1= 0.58	NW-SE; 135°	Straight	regular overhanging facades & asymmetry
12	El- dahab Street	Local street	H1/W = 1.0; H2/W = 1.0; H2/H1= 1.0	NW-SE; 135°	Straight	Covered street (Arcade)
13	El- omary Street	Local street	H1/W = 1.4; H2/W = 2.0; H2/H1= 1.4	NE-SW; 33°	Plover	regular overhanging facades & asymmetry

14	El-omary Street	Local street	H1/W = 1.0; H2/W = 1.0; H2/H1= 1.0	NW-SE; 131°	Plover	Covered street (Arcade)
15	Salah Al-Din Street	main street-fir.	H2/W = 0.35	NE-SW; 42°	Straight	regular overhanging facades & trees
16	Al-Istiklal Street	collector street	H1/W = 0.80; H2/W = 1.15; H2/H1= 1.43	NW-SE; 167°	Curved	regular overhanging facades, asymmetry & trees
17	Al-Istiklal Street	collector street	H1/W = 0.40; H2/W = 0.65; H2/H1= 1.62	NE-SW; 48°	Curved	regular overhanging facades, asymmetry & trees
18	Al-Sahaba Street	collector street	H1/W = 1.37; H2/W = 0.90; H2/H1= 0.65	NW-SE; 152°	Straight	regular overhanging facades & asymmetry
19	Al-Sahaba Street	collector street	H1/W = 1.30; H2/W = 0.92; H2/H1= 0.70	NW-SE; 147°	Straight	regular overhanging facades, asymmetry & trees covering the street
20	Al-Jalaa street	main street-fir.	H1/W = 0.65; H2/W = 1.2; H2/H1= 1.8	NE-SW; 46°	Straight	regular overhanging facades, asymmetry & trees
21	Al-Wehda streets	main street-sec	H1/W = 1.14; H2/W = 0.48; H2/H1= 0.42	NW-SE; 136°	Straight	regular overhanging facades & asymmetry
22	Al-Wehda streets	main street-sec	H1/W = 2.2; H2/W = 0.48; H2/H1= 0.2	NW-SE; 136°	Straight	regular overhanging facades, asymmetry & trees
23	Palestine street	collector street	H1/W = 0.6; H2/W = 1.0; H2/H1= 1.6	NE-SW; 46°	Straight	regular overhanging facades & asymmetry
24	Palestine street	collector street	H1/W = 1.35; H2/W = 1.35; H2/H1= 1.0	NE-SW; 46°	Straight	regular overhanging facades
25	Omar Al-Mukhtar Street	main street-sec	H1/W = 0.18; H2/W = 0.18; H2/H1= 1.0	NW-SE; 131°	Straight	regular overhanging facades, asymmetry & trees
26	Al-Nasr Street	main street-fir.	H1/W = 2.2; H2/W = 0.48; H2/H1= 0.2	NE-SW; 43°	Straight	regular overhanging facades & asymmetry



Pt.1

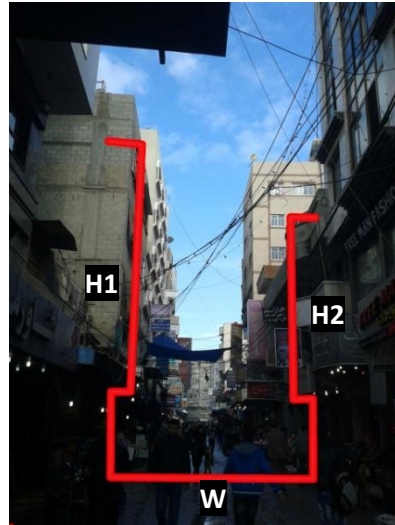

Pt.2

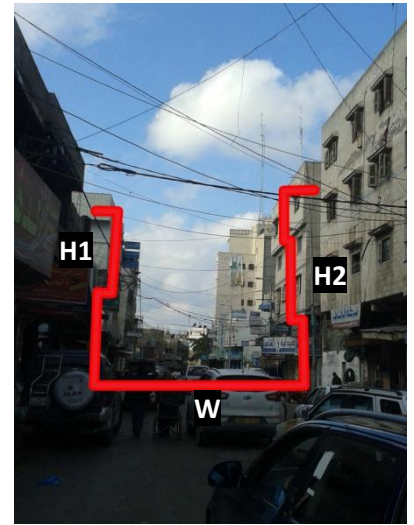

Pt.3

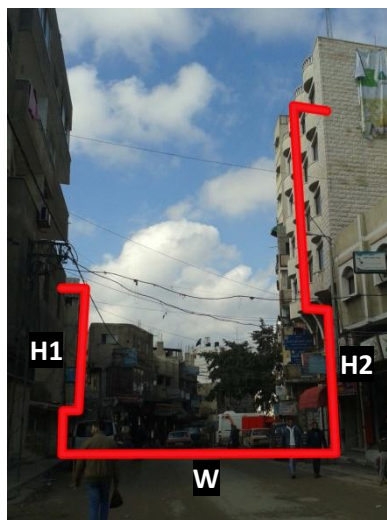

Pt.4

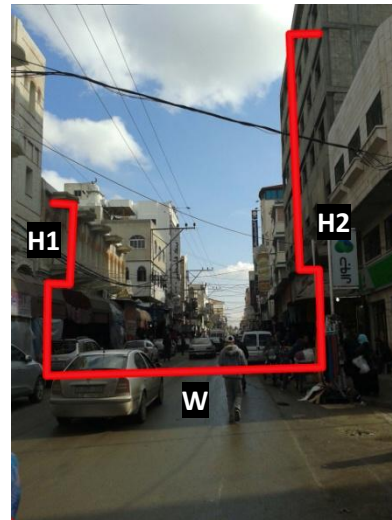

Pt.5

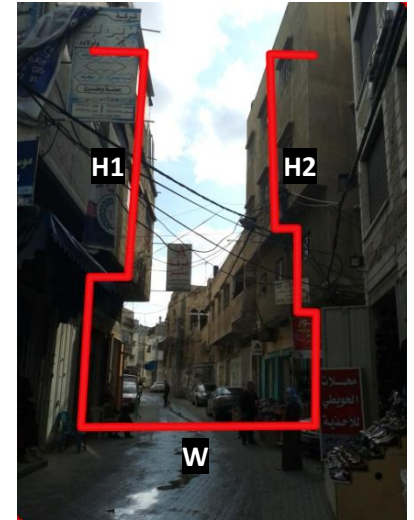

Pt.6

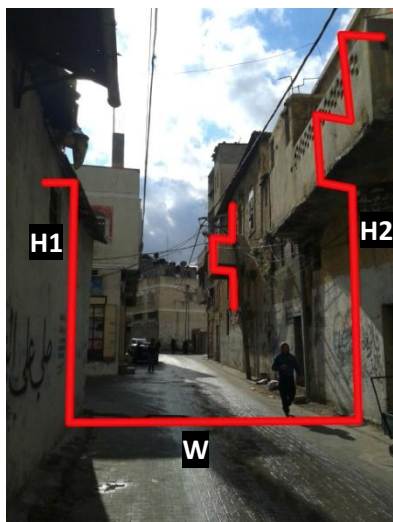

Pt.7



Pt.8

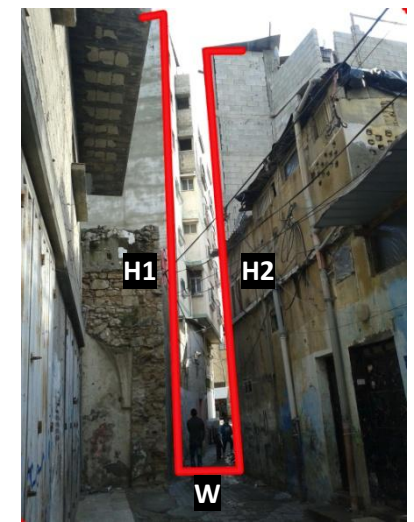

Pt.9

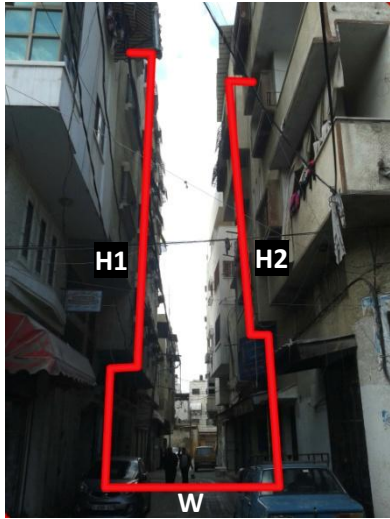

Pt.10

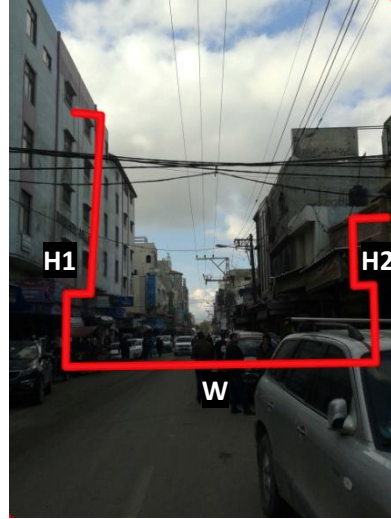

Pt.11



Pt.12

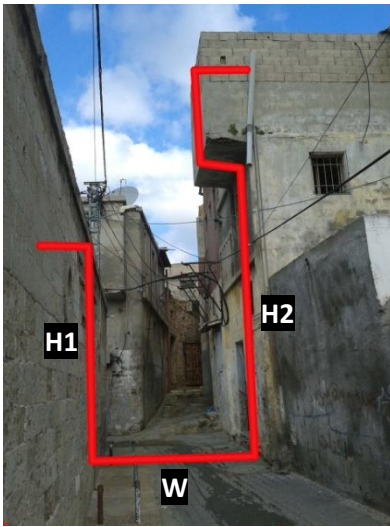

Pt.13



Pt.14



Pt.15



Pt.16

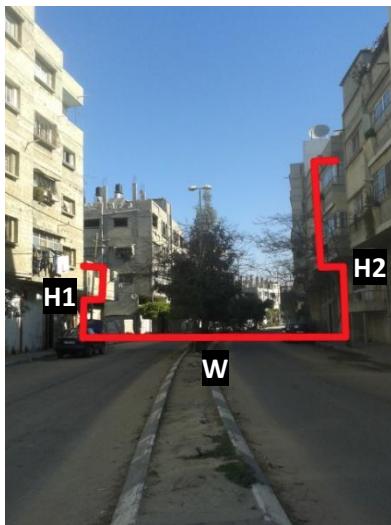

Pt.17

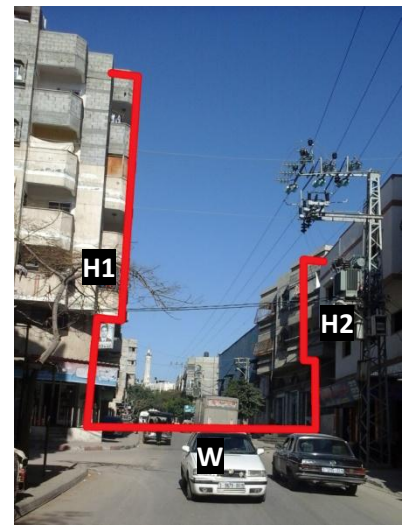

Pt.18

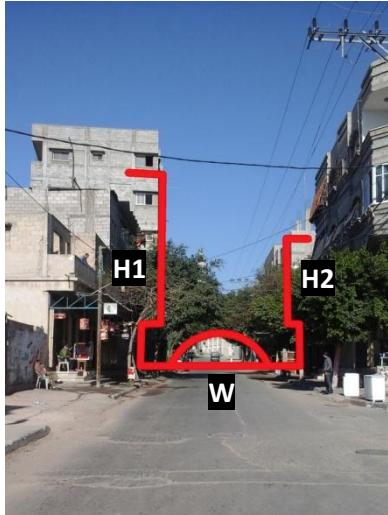

Pt.19

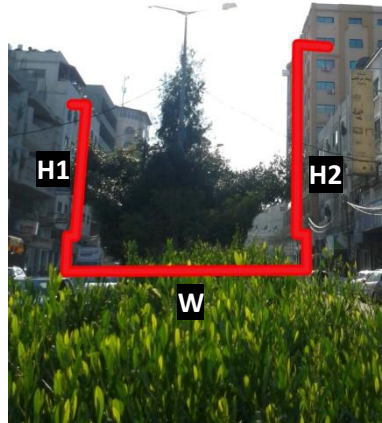

Pt.20

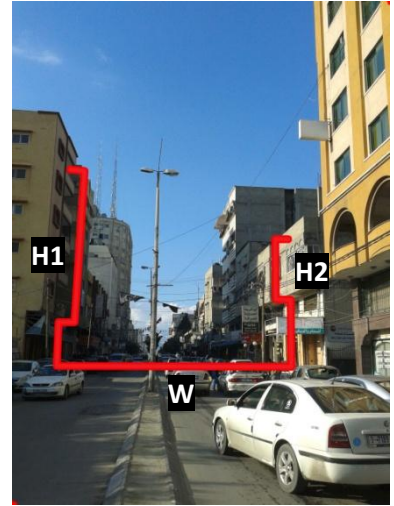

Pt.21



Pt.22

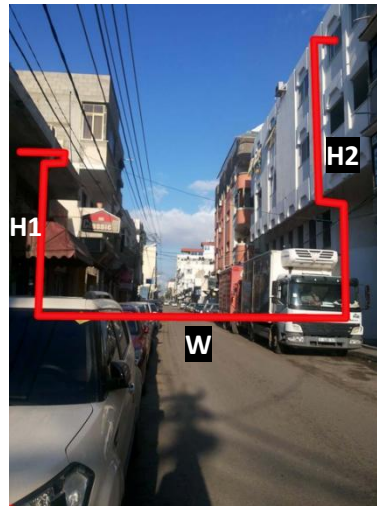

Pt.23

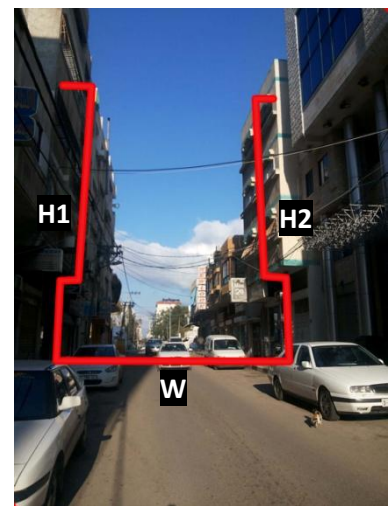

Pt.24



Pt.25

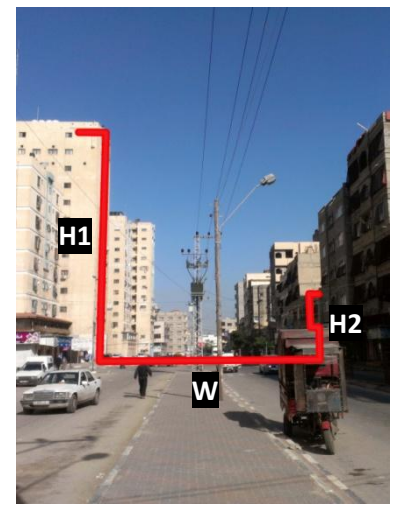

Pt.26

Figure (3.25): Photographs of selected sites within the Gaza city

3.4.5 Residential buildings in the Gaza Strip

Residential buildings in the Gaza strip are often built with contemporary construction methods, most notably the structural system with reinforced concrete foundations, columns, and ceilings and the walls are made of concrete hollow blocks, while the windows are single-glazed with aluminum frame. These buildings do not take into consideration the climatic factors especially with concrete as a main construction material without any treatment or thermal insulation leads to a hot indoor climate in summer and a cold indoor climate in winter.

Classifications of buildings according to the set back line, height of the building, number of floors and built up area were determined in the structural plan system for Gaza City according to the classifications of the land, with the exception of refugee camps which are not covered by any building law, although it is the most dense areas in the Gaza Strip. The maximum built site coverage ranges between 60% in multi story buildings and in zoning district (b), and 80% in zoning district (c). The minimum area of parcel range between 250 m² in zoning district (b) and (c), and 1000 m² in multi story buildings. Spacing between buildings is determined according to the side and rear setback. On the other hand, the relationship between building height and streets width have not been studied except in multi-storey buildings where the maximum height of these building does not exceed 1.5*street's width. Table (3.2) illustrates the main zoning district regulations in the Gaza Strip (Ministry of Local Government, 1997).

Table (3.2): Zoning district regulations in the Gaza Strip
Source: Ministry of Local Government

Area	The minimum area of parcel	The maximum built site coverage	The maximum Number of floors	The maximum height (m)	setbacks		
					The front	The side	The rear
Zoning district (b)	250	60%	Ground floor + 5	20	3	2	2
					Façade width should be at least 25 m		
Zoning district (c)	250	80%	Ground floor + 5	20	2	1	1
					Façade width should be at least 20 m		
Multi-storey buildings	1000	60%	-	1.5*street's width	organization structure extent of the street	10% of height	15% of height

Residential buildings can be classified into two main types, which are detached house and apartment building (Hadid, 2002). The separate house is a popular style in the Gaza Strip. The area of this style can be determined according to accommodate the main functions which are 2-3 bedrooms, 1-2 bathrooms, kitchen, guest room, setting room, and balconies. The building has four facades open to the natural environment for ventilation which considers the most characteristic of this style. A villa house is another style of this type, its area ranges from 200 m² to 500 m². The other type is residential apartment, it is a new style in the Gaza city, where it appeared as a result of increased housing needs and the small land area leading to the vertical expansion in apartments which can be classified as low-apartment building and tower-apartment. The areas of apartments rang from 80m² to 180 m² with the same functions as in the separate house. The design depending on number of apartments in the level. In most of the low-apartment buildings contain 1, 2, or 3 apartments in the same floor, and the number of floors can reach 6 floors. Each apartment has three facades open to the natural environment. The number of floors can reach more than 15 floors in the tower apartments.

Generally, the percentage of separate buildings and villas is about 39.7% in the Gaza Strip while the percentage of apartments both in low-rise residential buildings and high residential buildings reaches to 59.6% (PCBS, 2007).

3.5 Conclusion

The chapter stated a general review about the definition, function and components of street design. It is clear that the street width is an important dimension and needs to be considered in relation to function and aesthetics. The conclusion confirmed that the scale of the buildings on either side should be taken into account to determine streets width between buildings. In addition, it was concluded that the four functional categories of the hierarchy can promote effectively to regulate traffic and pedestrians movement.

Urban street design affects human thermal comfort in both outdoor and indoor spaces. This chapter discussed many factors affecting thermal comfort in urban street canyons including canyon geometry and orientation, wind flow, use of galleries, canyon asymmetry, overhanging facades and use of vegetation. It was concluded that these factors

can achieve thermal balance in outdoor comfort, limited the period of discomfort and reduce a building's energy consumption.

The chapter also presented the situation of energy, climate, streets and buildings in the Gaza strip. It is clear that the Gaza Strip is suffering from many problems related to energy due to apparent shortage of electricity supply and the lack of optimal exploitation of renewable energy potential. In addition, there are some problems in urban planning in the Gaza Strip and it does not take into consideration the climatic factors. Also, the chapter concluded that the residential buildings form, height and materials in the Gaza Strip do not pay a special attention to the climatic factors and the ratio between buildings height and streets width have not been studied. Therefore, the next chapter will display a parametric study of street configuration effect on a building's energy consumption in the Gaza Strip using three dimensional modeling programs.

Chapter 4: The effect of streets morphology on the incident solar radiation

4.1 Introduction

It has been shown in the previous chapter that various shapes of an urban street, orientations, galleries, asymmetry, overhanging facades and vegetation affect outdoor thermal comfort without clarifying the impact of these factors on the incident solar radiation falling on facades. A street configuration is one of the main determinates which defines outdoor environment and its relationship with the indoor conditions, and affecting the received amounts of solar radiation by the building envelope. It was found in previous studies that canyon geometry (H/W) play an important role in identifying a street's climatic features and responsible for a great shading benefits. In addition, it was found that galleries and asymmetry can contribute effectively to mitigating thermal stress in the streets. However, the impact of the different heights of buildings (asymmetry) with the (H_2/H_1) ratio and gallery dimensions have not been studied extensively especially on the radiation falling on facades and thus its effect on indoor places.

In this chapter, seven parameters were studied to investigate their effects on the incident solar radiation falling on the street space and building facades on both sides and thus find out optimum streets morphology. The study parameters are aspect ratio (H/W) for symmetrical urban canyons, street orientation from $0^\circ E$ to $90^\circ E$, galleries with different depth and height, asymmetry with large openness to the sky, overhanging facades with small openings to the sky, vegetation with different densities and locations, and geometric shapes of the street. Thermal simulation software ECOTECH and IDA Indoor Climate and Energy were employed in order to evaluate the effect of different parameters on the amount of incident solar radiation falling on facades and streets in Mediterranean climate. Then, comparison of the obtained results is performed to find which one receives less solar radiation in summer and more solar radiation in winter and thus reduces the energy consumption.

4.2 Study Parameters

There are several parameters related to solar radiation analysis. These parameters, which were examined in this study include simulation tools and validity, climate data, building parameters, and streets geometry. Simulation tools, building parameters and

climatic data are assumed to be fixed terms to evaluate the effect of streets morphology on the incident solar radiation.

4.2.1 Simulation Tools and Validity

Two popular simulations tools namely IDA Indoor Climate and Energy (IDA ICE) and ECOTECH were used in the present study. A short description is provided for each tool including features and its importance to the study:

4.2.1.1 IDA Indoor Climate and Energy (IDA ICE)

IDA ICE is a whole year detailed and dynamic multi-zone simulation application for the study of indoor climate of individual zones within a building as well as energy consumption of an entire building (EQUA Simulation AB, 2013a). IDA ICE is an extension of the general IDA Simulation Environment. This means that the advanced user can simulate any system whatsoever with the help of the general functionality in the IDA environment. Normally, the system to be simulated consists of a building with one or more zones, a primary system and one or more air handling systems. Surrounding buildings might shade the building. The air inside the building contains both humidity and carbon dioxide. Weather data is supplied by weather data files, or is artificially created by a model for a given 24-hour period. Consideration of wind and temperature driven airflow can be taken by a bulk air flow model (EQUA Simulation AB, 2013b). In addition, user can simulate four different types of simulations: heating load calculation, cooling load calculation, energy calculation and customized calculation, see figure (4.1). Predefined building components and other parameter objects can be loaded from a database.

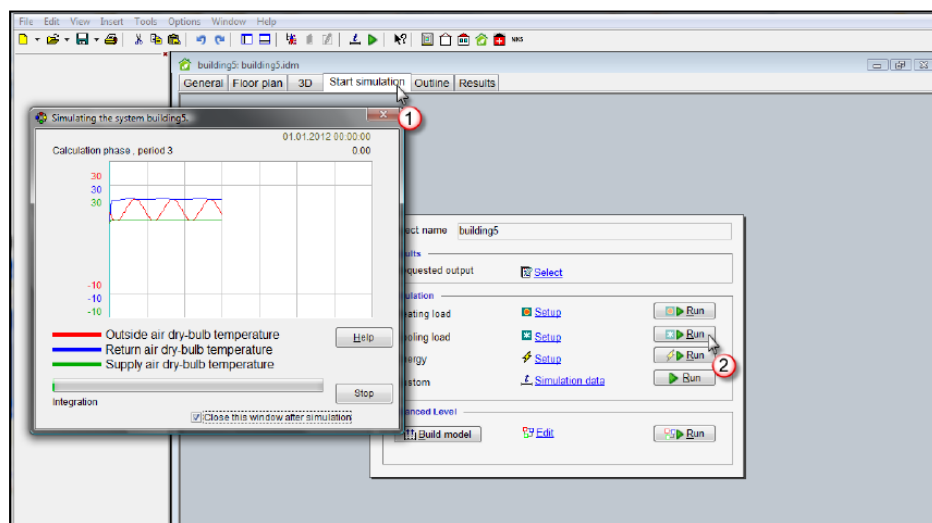

Figure (4.1): Simulation tab in IDA Indoor Climate and Energy (IDA ICE) program
Source: EQUA Simulation AB, 2013a

4.2.1.2 ECOTEECT

ECOTEECT is a software package with a unique approach to conceptual building design. It couples an intuitive 3-D design interface with a comprehensive set of performance analysis functions and interactive information displays. ECOTEECT offers a wide range of internal analysis functions which can be used at any time while modeling. These provide almost instantaneous feedback on parameters such as sun penetration, potential solar gains, thermal performance, internal light levels, reverberation times and even fabric costs (Marsh, 2003). ECOTEECT analysis offers several simulation applications including:

- Calculate annual, monthly, daily, and hourly total energy use of the model,
- Calculate heating and cooling loads,
- Visualize incident solar radiation on surfaces over any period
- Display the sun's position and path relative to the model at any time as well as annual cumulative solar radiation over the external surfaces, see fig.(4.2).

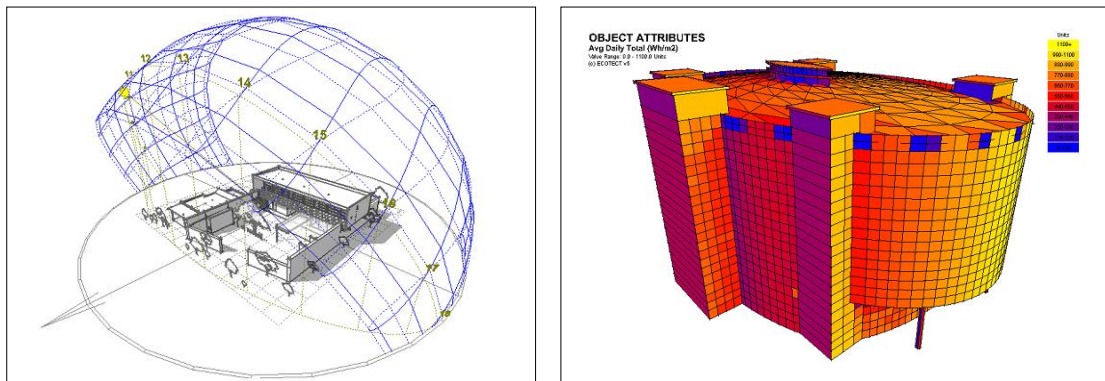

Figure (4.2): L: Some applications of ECOTEECT program, R: Overlaying a Sun-path on the model view, b : Annual cumulative solar radiation over the external surfaces

4.2.2 Climatic Parameters

The use of climatic parameters in any simulation analysis is represented by climate weather data files for specific city. These files were arranged by World Metrological Organization region and country. The weather data file consists of group of locations and climatic information included latitude, longitude, climate type, summer and winter dates, and other climatic parameters such as temperature, humidity, wind speed, and solar radiation (U.S. Department of Energy, 2012).

Because of the unavailability of weather data file for the Gaza Strip in any formats, the climatic weather data file for Tel. Arabia (Tel. Aviv) is used. The effect of coastal climate of Mediterranean Sea for Gaza and Tel. Aviv is similar. The average monthly temperature in the Gaza Strip and Tel. Arabia ranges from 25C° in the summer to 13C° in the winter. Simulations were carried out using the Tel. Aviv-Bet Dagan weather file during the summer and winter months. Local latitude is 32.0 N, longitude 34.8 E and the elevation is approximately 20 m above sea level. The internal heat gain from occupancy, appliances and the ventilation heat gain were considered constant in the simulation, as the study concerns the incident solar radiation on the facades which overlooks the street and on the street ground.

4.2.3 Building Parameters

Residential buildings in the Gaza Strip have different features in terms of area, height, type, and volume. Basically, this study estimates the effect of streets morphology on incident solar radiation falling on the central building. The spacing between adjacent buildings is taken to be 4m and the building façade is taken to be 28.72m wide to represent zoning district (b) in the Gaza Strip, where building laws reported that facade width which overlooks street should be at least 25 m, see table (3.2), at the same time the rectangular shape for building is assumed to have a width ratio of 0.618 as it represents the golden section. The domain simulated is composed of six buildings with constant height equals to 20 m separated by a street taking into consideration east-west and north-south oriented streets axis for comparison. It is worth mentioning that, suffice to study the effect of the urban street geometry either on the walls facing east or the walls facing west in (N-S) streets orientation, which allows nearly equal access of radiation to the two facades overlooking the street as a result of the movement of the sun from east to west. In contrast, study the effect of orientation should be on the two facades overlooking (E-W) streets orientation. On the other hand, suffice to study the effect of architectural elements such as galleries, asymmetry, overhanging and vegetation only on the walls facing south, where it receives all solar radiation while the sun does not reach to the northern façade and thus it does not need these architectural elements. Figure (4.3) illustrates the sun path in summer and winter period and its relation with the incident solar radiation falling on building facades in east-west and north-south oriented streets axis.

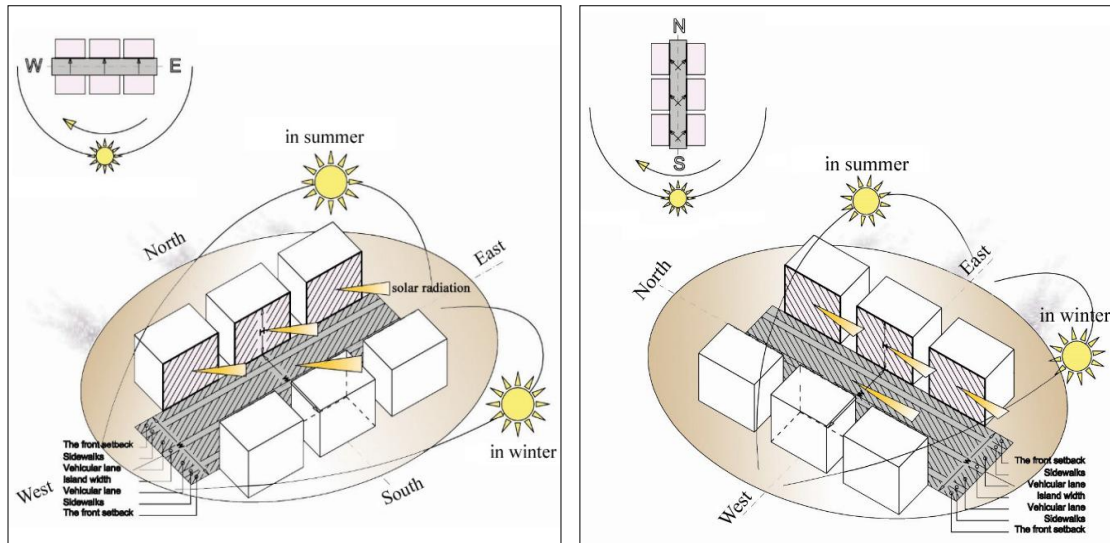

Figure (4.3): L: The sun path in summer and winter period and its relation with the building facades in East – West street orientation, R: in North – South street orientation.

4.2.4 Urban Street Geometry

This study focused on the effect of the urban street geometry and orientation on the amount of incident solar radiation falling on streets and facades overlooking them. Incident solar radiation is considered one of the most important variables in the Mediterranean climate affecting the heating and cooling energy consumption.

4.2.4.1 Parametric Investigation

A number of street geometries were selected to investigate their effects on the incident solar radiation. The following are the parameter combinations investigated in the study.

- **Aspect Ratio (H/W):** Symmetrical urban canyons with rectangular shape with H/W equal to 0.5, 1, 1.5, 2, 2.5, 3, 3.5 and 4 for North – South orientation were considered. The block consists of six buildings with a constant height (20 m) separated by a street of a variable width, see figure (4.4). Table (4.1) display the investigated urban canyons.

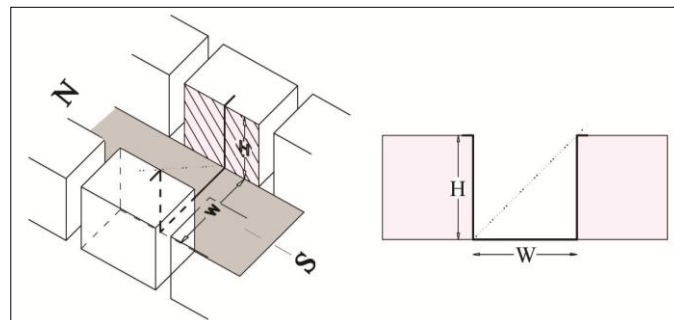

Figure (4.4): The concept of aspect ratio parameter (H/W)

Table (4.1): The urban canyon parameters investigated in the study

Horizontal Plan			
Vertical section			
Aspect ratio (H/W)			
4.0	3.5	3.0	2.5
2.0	1.5	1.0	0.5

- **Effect of Street Orientation:** Seven values of orientations including intermediate orientations NE-SW for H/W equal to 0.5, 1, 1.5, 2, 2.5, 3, 3.5 and 4 were considered. Figure (4.5) show these values which are 0°E, 15°E, 30°E, 45°E, 60°E, 75°E and 90°E (N-S).

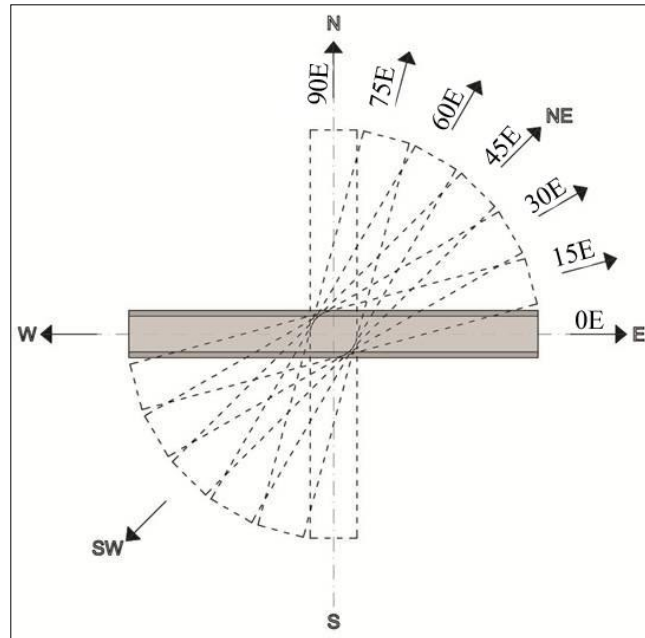

Figure (4.5): The seven values of street's orientation considered in the study

- **Galleries:** An urban canyon of $H/W = 2$ - considered as an average profile between shallow and deep profiles- with different galleries depth and height were studied, see figure (4.6). Seven values of gallery width to street width ratio (w/W) were simulated, which are 0.2, 0.4, 0.6, 0.8, 1.0, 1.2 and 1.4. In addition, a gallery canyon of $(w/W) = 1.0$ was simulated, taking into consideration a variable gallery height. Eight values of gallery height to building height ratio (h/H) were considered, which are 0.2, 0.3, 0.4, 0.5, 0.6, 0.7, 0.8 and 0.9, see figure (4.7).

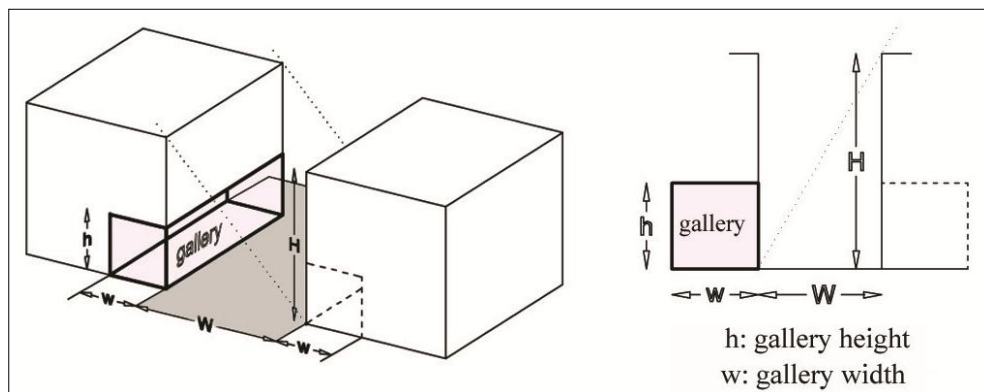

Figure (4.6): The concept of gallery parameter

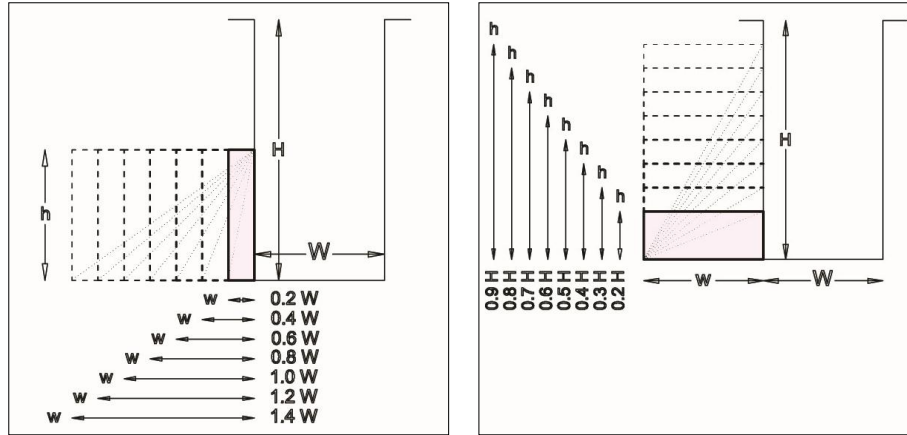

Figure (4.7): L: Seven values of gallery width to street width ratio simulated in the study, R: Eight values of gallery height to building height ratio considered

- **Asymmetry:** Asymmetrical urban canyon with large openness to the sky were studied, see figure (4.8). Nine values of building (2) height to building (1) height ratio (H_2/H_1) with a street of a constant width were considered. The ratios are 0.2, 0.4, 0.8, 1.2, 1.6, 2.0, 2.4, 2.8 and 3.2, see figure (4.9).

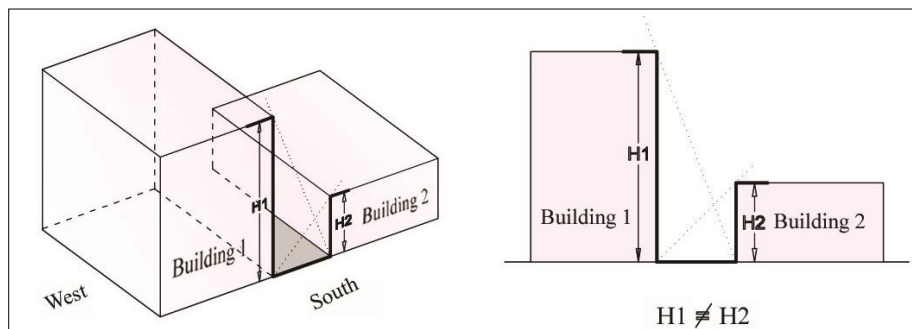

Figure (4.8): The concept of Asymmetrical urban canyon parameter

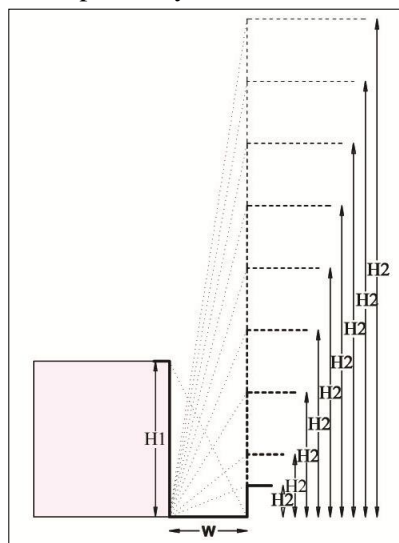

Figure (4.9): Nine values of building (2) height to building (1) height ratio (H_2/H_1)

- **overhanging facades:** A symmetrical urban canyon including overhanging facades and with small openings to the sky were considered, see figure (4.10). The study simulated eight values of overhanging facades width to street width ratio (w'/W), namely 0.1, 0.15, 0.20, 0.25, 0.3, 0.35, 0.4 and 0.45, see figure (4.11).

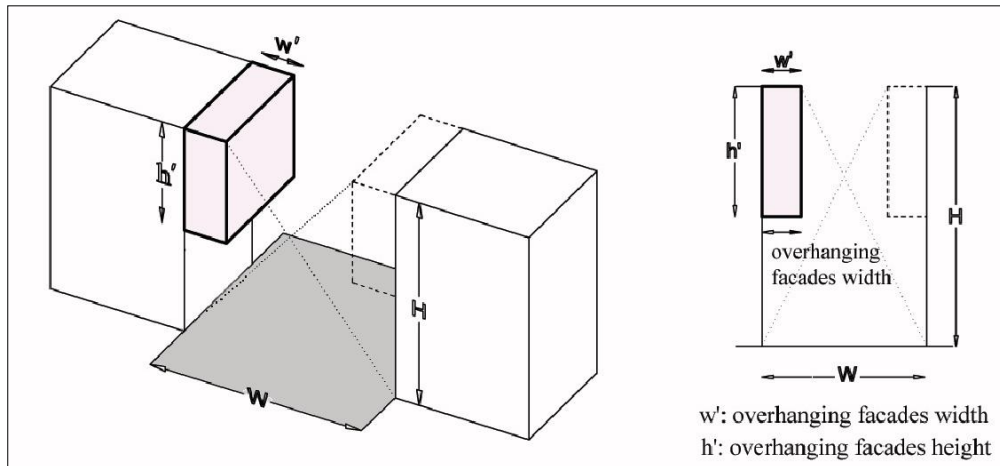

Figure (4.10): The concept of overhanging facades parameter

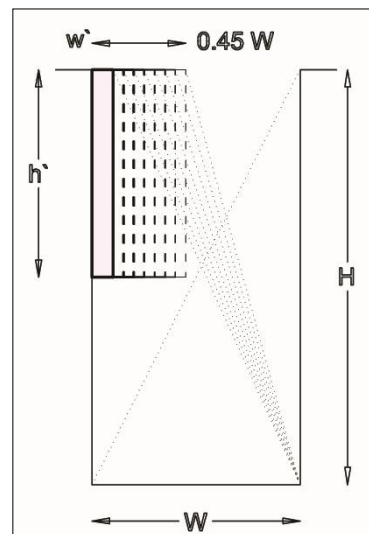

Figure (4.11): Eight values of sky opening width to street width ratio considered in the study

- **Vegetation**

This study investigates the effects of the numbers of trees and their locations on solar radiation. The trees have a total height of 5.5 m, including a leafless base of 2.4 m height and a dense crown, which represents one of the common options in trees dimension in

Gaza (ElHissi, 2012). Table (5.2) show parameters of trees numbers and locations investigated in the study.

Table (4.2): Trees numbers and locations parameters investigated in the study

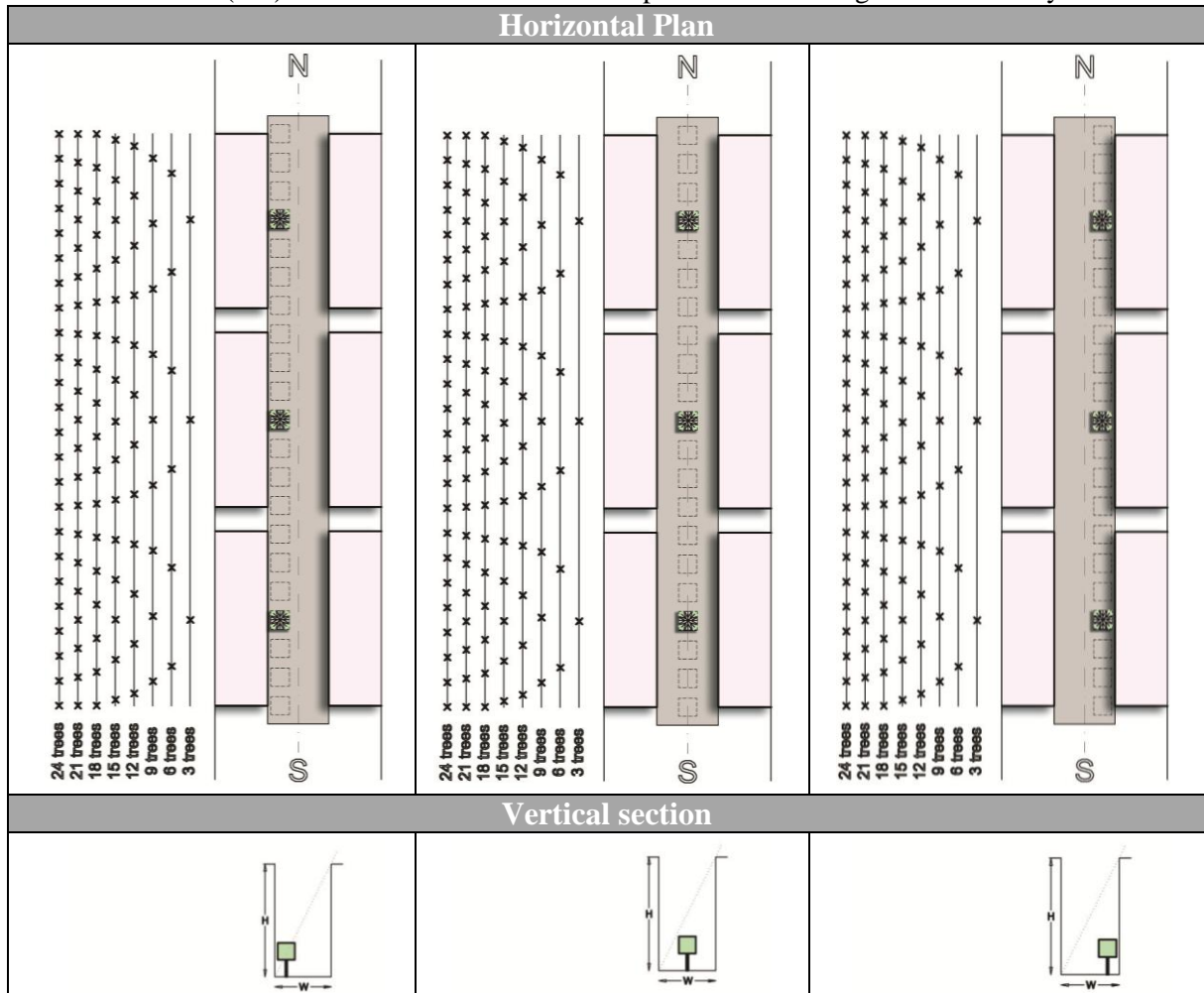

- **Geometric shape of the street**

The three main geometric shape of streets which were investigated in the study are straight street, curved street and plover street, see figure (4.12).

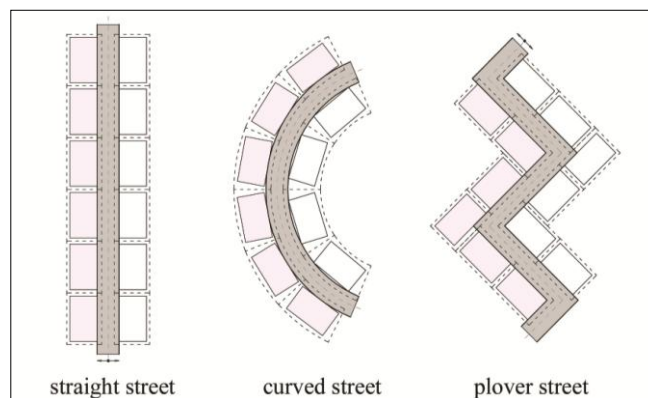

Figure (4.12): The three main geometric shape of streets simulated in the study

The output data of simulation will be discussed in more details in the following sections.

4.2.4.2 Discussion of results

The simulation results were expressed in terms of the incident solar radiation on the facades of buildings overlooking the street and on the street ground the same (in KWh/m²). The following sections discuss the results of ECOTECT and IDA ICE programs in order to select the optimum design.

1. Effect of Aspect Ratio (H/W)

Figure (4.13) shows the incident solar radiation on the facade of central building overlooking the street and on streets ground during the summer and winter months for symmetrical urban canyons oriented N-S with aspect ratios H/W varying from 0.5 to 4. Basically, incident solar radiation decreases with the increase of the aspect ratio due to the increasing of shading potential. The shallowest canyon H/W = 0.5 receives the largest amount of solar radiation, the deepest canyon H/W = 4 receives the least amount of solar radiation. The shallowest canyon H/W = 0.5, as expected, achieves the best thermal behavior in the cold days and the worst behavior in the hot days because it is the most exposed to direct solar radiation (like Salah Al-din Street in Gaza city). But the deepest canyon H/W = 4, as expected, achieves the best thermal behavior in the hot days because it is protected from the sun and the worst behavior in the cold days due to the effect of the shadows (like old town streets in Gaza city). The same trend can be observed in IDA ICE program. Decreasing the aspect ratio from 4.0 to 0.5 increased amount of solar radiation but with higher values, see figure (4.14). The discrepancy in results between ECOTECT and IDA ICE can be explained as a result of different calculation algorithm.

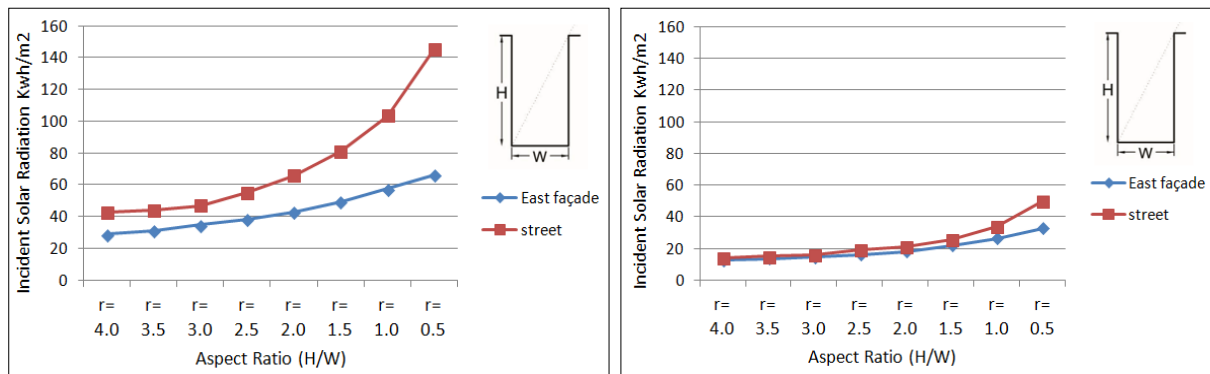

Figure (4.13): L: Incident solar radiation on the wall facing east and (N-S) street as a result of varying the aspect ratio in the summer months, R: in the winter months by ECOTECT.

Knowing that L: Left figure, R: Right figure

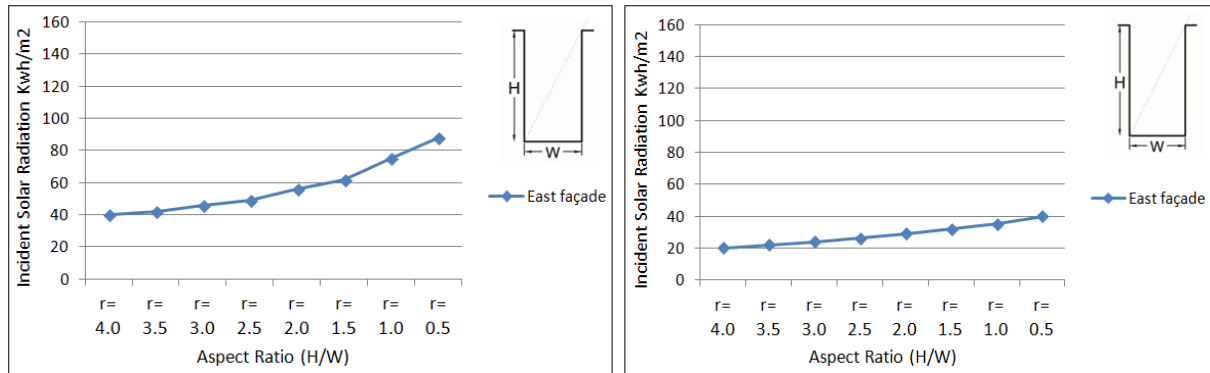

Figure (4.14): L: Incident solar radiation on the wall facing east as a result of varying the aspect ratio in the summer months, R: in the winter months by IDA ICE.

For more details, decreasing the aspect ratio from 4.0 to 0.5 in the summer period can increase the incident solar radiation on the wall facing east which overlooks the north-south oriented street axis by about 8%, 19.9%, 33%, 48.6%, 71%, 99.6% and 130.2% (about more than doubled) for aspect ratios H/W 3.5, 3.0, 2.5, 2.0, 1.5, 1.0 and 0.5 respectively. While increase the radiation during the winter months by about 7.1%, 14.2%, 26.7, 42.1, 71.8 %, 108.5% and 159.8%, see figure (4.15). So it is concluded that increasing the aspect ratio increases the shading potential which decreases the solar radiation. Thus, the shallowest canyon H/W = 0.5 is the warmest case study and the deepest canyon H/W = 4 is the coolest one.

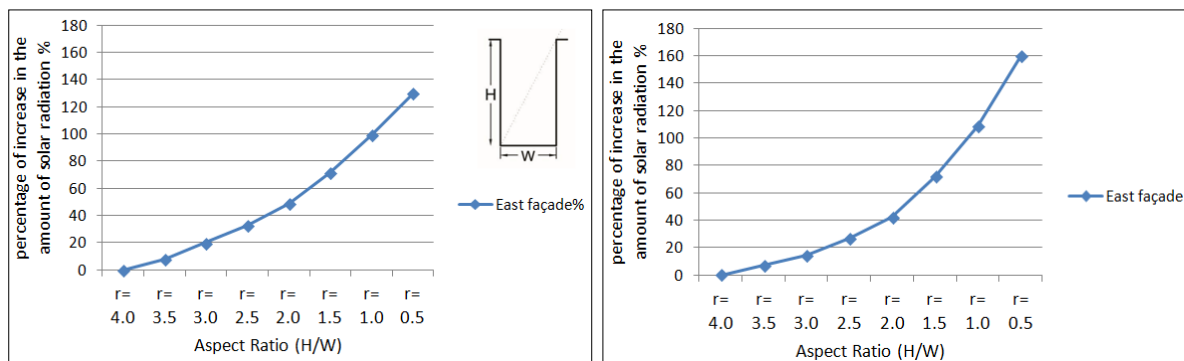

Figure (4.15): L: Percentage of increasing in incident solar radiation on façade overlooking the street as a result of varying the aspect ratio in summer, R: in winter by ECOTECT.

As the street with H/W = 0.5 provides the largest amount of desirable radiation in the cold days, and the street with H/W = 4 provides the least amount of undesirable radiation in the hot days. Intermediate case study between shallow and deep canyon H/W = 2 is most appropriate choice in the (N-S) street which can be applied in the Gaza Strip, where amount of solar radiation slightly increases for aspect ratio H/W > 2, and greatly increases for aspect ratio H/W < 2.

2. Effect of Street Orientation

The study investigates the amount of solar radiation on façades overlooking a street of seven orientations which are 0°E, 15°E, 30°E, 45°E, 60°E, 75°E, 90°E (N-S). The study takes into consideration a symmetrical streets with the eight aspect ratio (H/W) which are 0.5, 1, 1.5, 2, 2.5, 3, 3.5 and 4 in order to investigate the impact of this variable on affecting the role of street orientation. It is evident in figure (4.16) that the street orientation has an important impact in decreasing the amount of solar radiation on façades overlooking (E-W) street in the summer months especially in the lower aspect ratios. (E-W) street receives low amount of undesirable solar radiation compared with (N-S) street in the summer months, at the same time receives the largest amount of desirable solar radiation in the winter months.

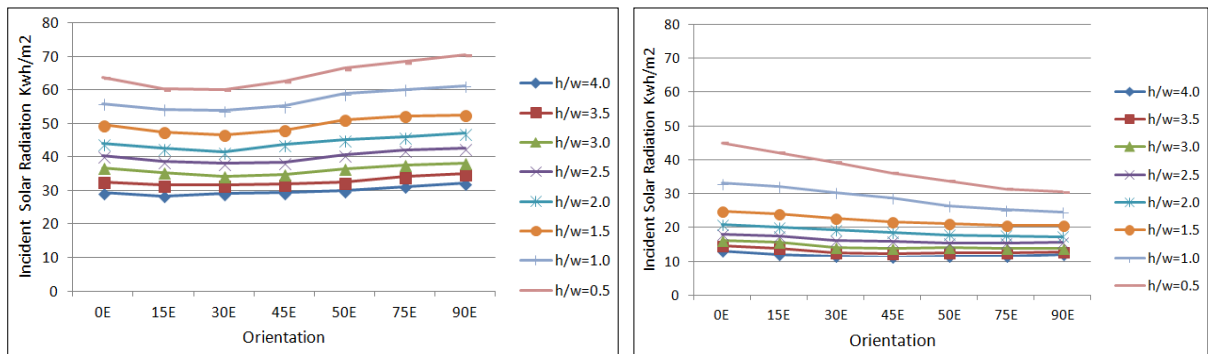

Figure (4.16): L: Incident solar radiation on façades overlooking a street with various orientations in the summer months, R: in the winter months by ECOTECT.

For more details, changing the street orientation from the north- south to the east- west orientation in the summer months with (H/W) equals to 2.0 can decrease the incident solar radiation on façades by about 11.75%. Thus, the façades overlooking N-S street is less shaded than the façades overlooking E-W street. The incident solar radiation on façades increases in the winter months by about 1.67%, 3.35%, 6.80%, 11.19%, 16.14% and 20.48% in the case of street orientation which are 75°E, 50°E, 45°E, 30°E, 15°E and 0°E (E-W) respectively, see figure (4.17). Hence, to reduce the bad impact of the undesirable radiation in the north- south streets in hot days and increase desirable radiation in cold days, it is advisable to choose street orientation throughout the design process by deviating the street toward the east-west. The east-west street orientation is more preferable for façades overlooking the street, as it receives the largest amount of desirable solar radiation in the winter and less amount of undesirable solar radiation in summer. It is noted that the E-W street orientation rare in Gaza city.

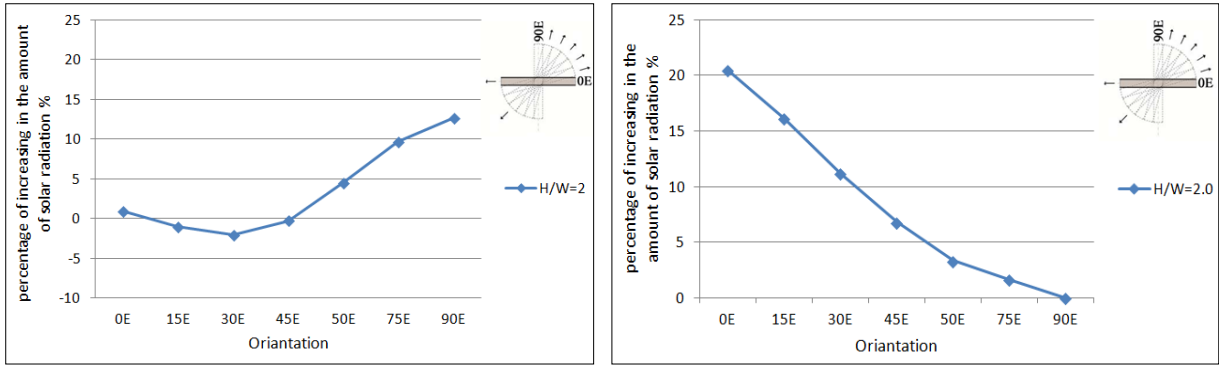

Figure (4.17): L: Percentage of reduction in incident solar radiation on façades overlooking the street in the summer months, R: Percentage of increasing in the winter months by ECOTECT.

With regards to the orientation effects on each façade separately, the north- south oriented street axis allows for more direct solar radiation penetration than in the case of the east- west street axis. In a N–S street, both façades overlooking street receives solar radiation penetration symmetrically. While in the E–W case the wall facing north and its sidewalks are in the shade most of the day. Thus, the distribution of the incident solar radiation for the two façades differs significantly. The effect of orientation on solar radiation penetration for the wall facing south in E–W street perverted toward east in N–S street and the wall facing north in E–W street perverted toward west in N–S street in the summer month is expressed in figure (4.18). The results indicate that changing the street orientation from the north- south to the east- west can increase solar radiation falling on the wall facing the south until reaches the east and decreases solar radiation falling on the wall facing the north until reaches the west. The graphs also shows that the increase in solar radiation falling on facades overlooking N–S street in the summer months exceeds the increase in solar radiation on facades overlooking E–W street. In contrast, the increase in solar radiation falling on facades overlooking E–W street in the winter months exceeds the increase in solar radiation on facades overlooking N–S street, see figure (4.19). So it can be concluded that E–W street is more appropriate orientation. Generally, lower aspect ratios needed for preventing full solar access during the summer months as a consequence of the high solar elevation in summer, but higher aspect ratios needed for providing sufficient solar access in the winter for all street orientation, see figure (4.19).

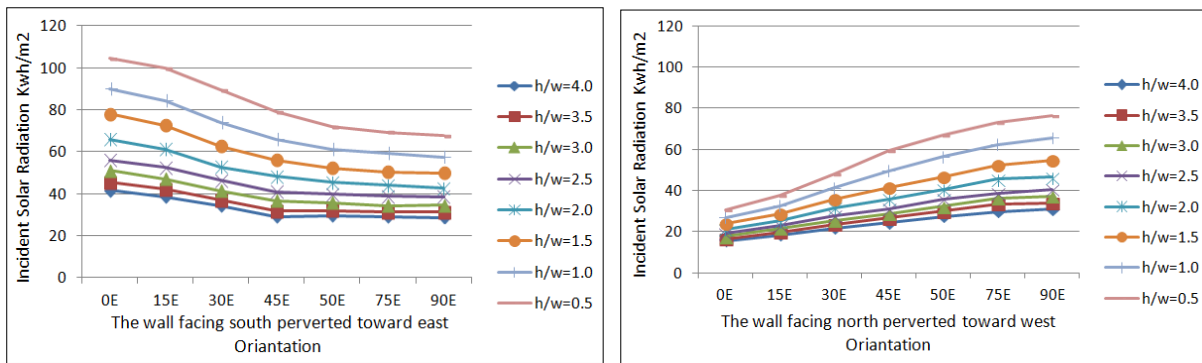

Figure (4.18): L: Incident solar radiation on the wall facing south perverted toward east in the summer months, R: on the wall facing north perverted toward west by ECOTECT.

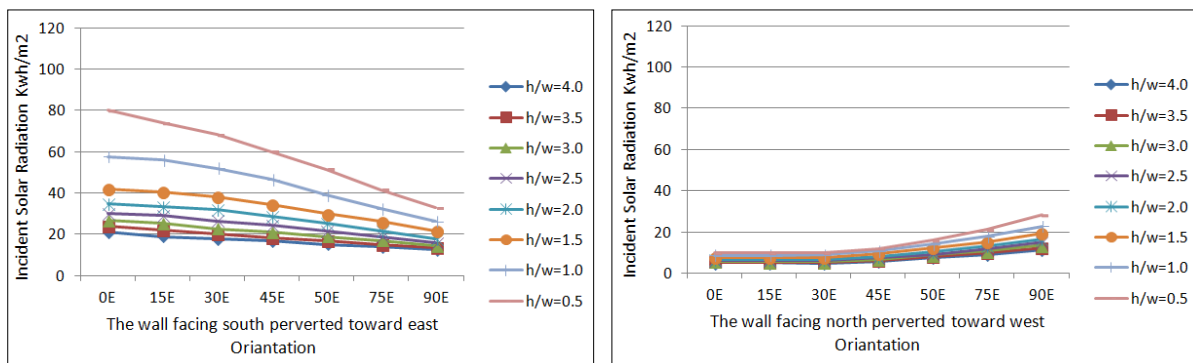

Figure (4.19): L: Incident solar radiation on the wall facing south perverted toward east in the winter months, R: on the wall facing north perverted toward west by ECOTECT.

With regard to the incident solar radiation on the ground between the buildings (streets). It is clear in figure (4.20) that the north- south oriented street axis receives less solar radiation than east- west street axis in the hot days because of the high solar elevation in summer. In addition, the distribution of the diurnal solar incident radiation is different for the two orientations. The east- west oriented street axis allows for more direct solar radiation on the street and less shading by building on the street due to the sun path in summer. While the north- south oriented street axis exposed to direct solar radiation during the middle of the day where the low altitude position of the sun in the morning and the evening of summer periods leads to more shading by buildings flanking street on the street ground.

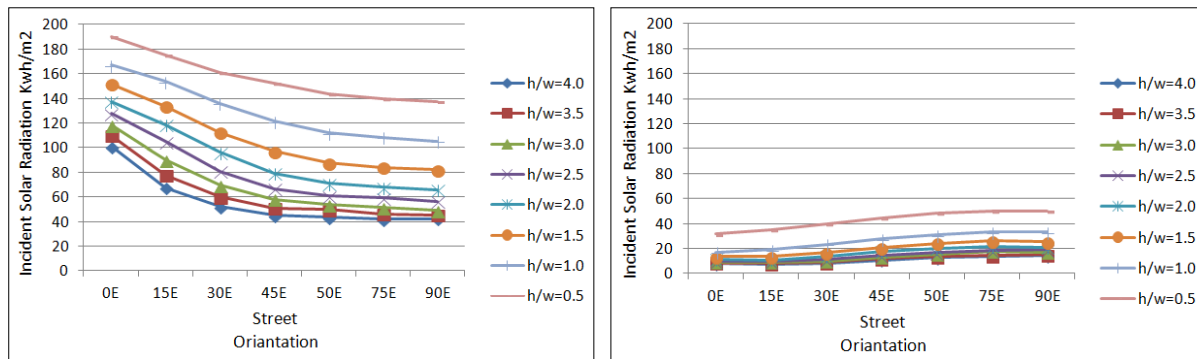

Figure (4.20): L: Incident solar radiation on the streets in the summer months, R: in the winter months by ECOTECT.

Because the study focuses on the solar radiation falling on facades, it can be concluded that south façades of building overlooking E-W street are more important to shade than north façades. On the other hand, east- west street axis should be provided with shading devices as it will affect significantly the solar radiation falling on the street. The following are some solutions that can reduce the incident solar radiation on façades as well as street for both orientations.

3. Effect of Galleries

The first case study is concerned with the impact of galleries width on the amount of solar radiation falling on façades. Figure (4.21) presents percentage of reduction in incident solar radiation on the wall facing east in (N-S) street and the wall facing south in (E-W) street within street canyons of aspect ratio $H/W = 2$ including galleries with different depths (w) and constant height (h). The gallery height is $0.5 H$ m and $0.2W$, $0.4W$, $0.6W$, $0.8W$, $1.0W$, $1.2W$ and $1.4W$ wide. The results indicate that the façades overlooking street canyons with galleries receives less amount of solar radiation than street canyons without galleries. In addition, reduction in incident solar radiation for the simulated shapes increased with increasing the gallery width to street width ratio (w/W) from 0.2 to 1.4. For more details, increasing the galleries width from $0.2W$ to $1.4W$ in the summer months can decrease the incident solar radiation on the wall facing east which overlooks the north-south oriented street axis in ECOTECT by about 13.1%, 20.83%, 24.57%, 26.75%, 27.8%, 28.5% and 28.6% for width ratios (w/W) equal to 0.2, 0.4, 0.6, 0.7, 0.8, 1.0 and 1.4 respectively. While decrease the radiation during the winter months by about 23.6%, 30.0%, 32.7%, 33.48%, 34.04%, 34.04% and 34.04%. In IDA ICE software, about

18.15%, 25.83%, 31.57%, 34.75%, 36.85, 37.91% and 38.6% of decreasing in the solar radiation for the same ratios in the summer months. While about 33.88%, 40.25%, 42.42%, 43.48%, 44.04%, 44.05% and 44.05% in the winter months, see figure (4.22). It is noticed that the percentage of reduction in incident solar radiation on façade with gallery width equal to 1.4W is significantly higher than the percentage of reduction on façade with gallery width equal to 0.2W. This means that the highest width ratio is the least amount of solar radiation. This is attributable to the effectiveness of horizontal shading of the deeper galleries. With respect to percentage of reduction in incident solar radiation in the winter months, it is noticed that the highest width ratio (w/W) received the least solar radiation. So, it is recommended to pay more attention to the gallery width to the street width ratio to be closer to the intermediate ratio to attract a large amount of solar radiation in the winter and less amount of radiation in the summer.

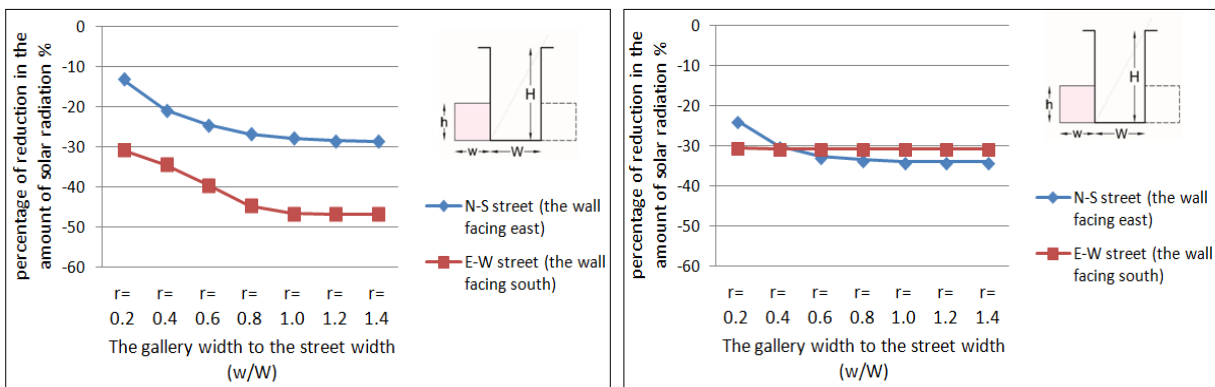

Figure (4.21): L: Percentage of reduction in incident solar radiation on façades overlooking (N-S) and (E-W) street as a result of varying the galleries width in the summer months, R: in the winter months by ECOTECT.

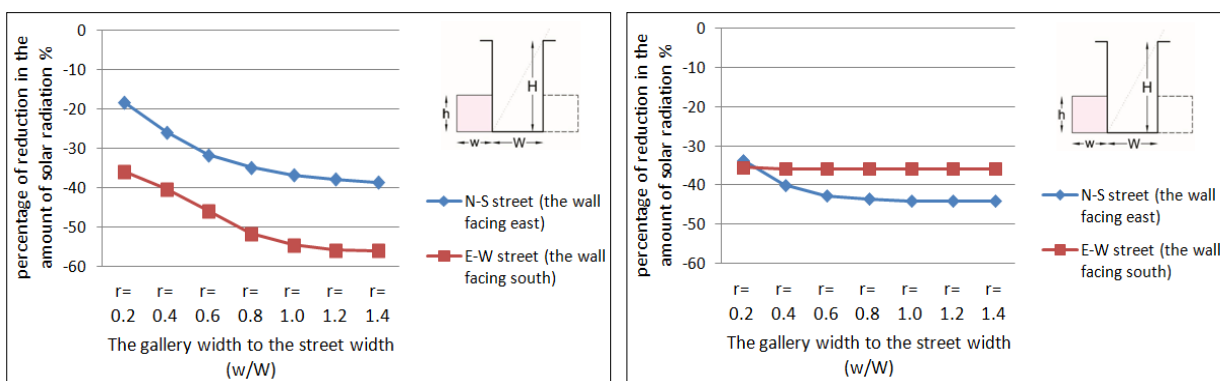

Figure (4.22): L: Percentage of reduction in incident solar radiation on façades overlooking (N-S) and (E-W) street as a result of varying the galleries width in the summer months, R: in the winter months by IDA ICE.

With respect to orientation, figure (4.21) shows that the street orientation with galleries has a great effect on reducing incident solar radiation percentage. For more clarity, changing the street orientation from the north- south to the east- west can decrease solar radiation during the summer months by about 30.78%, 34.37%, 39.55%, 44.73%, 46.64%, 46.74% and 46.74% in the case of width ratios (w/W) equal to 0.2, 0.4, 0.6, 0.8, 1.0, 1.2 and 1.4 respectively. However, the percentage of decreasing in the solar radiation for these seven ratios in IDA ICE are 35.78%, 40.37%, 45.95%, 51.73%, 54.64, 55.94 and 56.64% respectively, see figure (4.22). So galleries design in the wall facing south in (E-W) streets orientation is more effective and sensitive in reducing incident solar radiation percentage. Hence, it is possible to minimize the bad impact of the wall facing the south in (E-W) street orientation by increasing the width of gallery to get a large amount of shading. In contrast, the effect of galleries in the east-west oriented street axis in the winter period is not remarkable. This is attributable to the low altitude position of the sun in the winter periods and the lack of solar radiation intensity. Hence, E-W streets are warmer than N-S streets especially in winter.

The second case study is concerned with the impact of galleries height on the amount of solar radiation falling on façades. The simulated shapes have constant width of galleries and different galleries height (h) for N-S and E-W oriented street axis. The gallery width is $0.5 W$ and $0.2H$, $0.3H$, $0.4H$, $0.5H$, $0.6H$, $0.7H$, $0.8H$ and $0.9H$ height. The results indicate that the percentage of reduction in incident solar radiation on façades overlooking streets during the summer months are decreased with increasing the gallery height to the building height ratio (h/H) from 0.2 to 0.9. For more details, increasing the galleries height from $0.2H$ to $0.9H$ in the summer month can decrease the incident solar radiation on the wall facing east which overlooks the north-south oriented street axis by about 39.88%, 33.49%, 28.1%, 23.8%, 18.67%, 13.31%, 7.63% and 1.22% for height ratios (h/H) equal to 0.2, 0.3, 0.4, 0.5, 0.6, 0.7, 0.8 and 0.9 respectively. While decrease the radiation on the façade in the winter months by about 54.26%, 47.78%, 40.6%, 36.04%, 33.98%, 29.78%, 18.54% and 3.84%, see figure (4.23). So it is concluded that, it is possible to reduce the amount of solar radiation falling on facades by deeper and lower galleries because of a shorter period of exposure to the sun. Hence, attention is drawn here on the relevance of galleries dimensions for assessing comfort within galleries.

With regard to the impact of orientation along with the gallery height, figure (4.23) shows that the street orientation with galleries has a significant effect on reducing incident solar radiation percentage. Changing the street orientation from the north- south to the east- west can decrease solar radiation in the summer months by about 58.22%, 52.99%, 49.61%, 46.44%, 42.08%, 36.17%, 29.49% and 25.99% in the case of the gallery height to the building height ratio (h/H) equal to 0.2, 0.3, 0.4, 0.5, 0.6, 0.7, 0.8 and 0.9 respectively. Moreover, decrease solar radiation in the winter months by about 22.82%, 21.61%, 20.41%, 19.83%, 18.57%, 16.78%, 15.03% and 15.19%. So east-west oriented street axis with galleries effectively reduces the bad effect of undesirable radiation falling on the interface in the summer and reduces the percentage of reduction in solar radiation in winter where the sun's rays are desirable. Therefore, galleries design with different heights in southern façade overlooking the east-west street is more effective than the eastern or western façade overlooking the north-south street orientation.

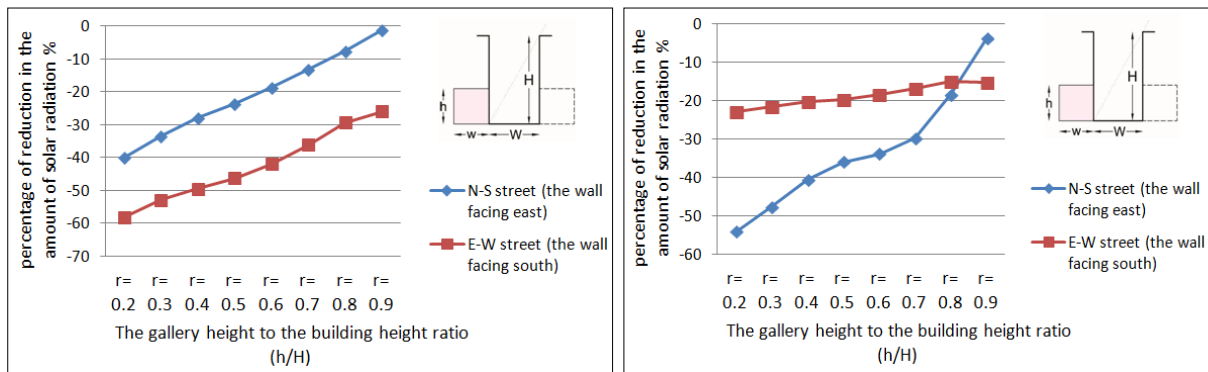

Figure (4.23): L: Percentage of reduction in incident solar radiation on façades overlooking (N-S) and (E-W) street as a result of varying the galleries height in the summer months, R: in the winter months by ECOTECT.

It should be noted that the galleries design also affect the amount of incident solar radiation falling on the street as interfaces. East-west street orientation with different galleries dimension were simulated to assess their impact on the amount of radiation falling on the street in the summer months. It is clear in figure (4.24L) that galleries with different widths can contribute efficiently in reducing amount of radiation falling on the area of the street. Moreover, the percentage of reduction in incident solar radiation for the simulated cases are increased with increasing the gallery width to street width ratio (w/W) from 0.2 to 1.4. On the other hand, galleries with different height can reduce the radiation, and the percentage of reduction in incident solar radiation are decreased with increasing

the gallery height to building height ratio (h/H) from 0.2 to 0.9, where deeper and lower galleries cast its shadow on the street. Thus, the thermal situation in street with galleries is better than completely irradiated street. Thus, galleries are considered a good way to protect pedestrian spaces.

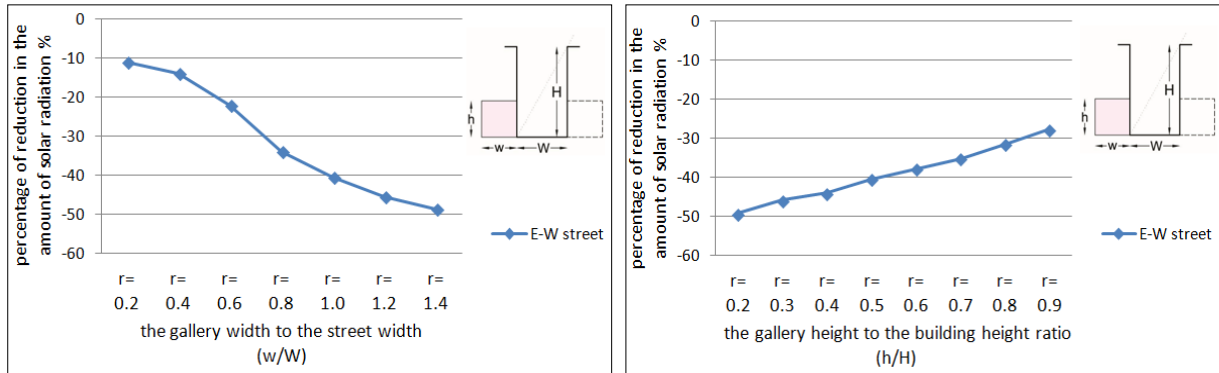

Figure (4.24): L: Percentage of reduction in incident solar radiation on (E-W) street as a result of varying the galleries width, R: as a result of varying the galleries height by ECOTECT.

It is worthy of note that, the dimension of the gallery in combination with the street orientation and aspect ratio of street canyon are all decisive. Hence, the reduction in undesirable radiation whether on the street or interfaces observed in the simulated cases increased for deeper galleries and decreased for higher galleries.

4. Effects of the canyon Asymmetry

Figure (4.25) presents the percentage of increasing and reduction in solar radiation on façades overlooking asymmetric streets ($H1 \neq H2$) for north-south and east-west oriented street axis taking into consideration constant height ($H1$) and constant width of street (W) knowing that $H1$: Height of the wall facing east overlooking (N-S) and the wall facing south overlooking (E-W) street, but $H2$: Height of the wall facing west overlooking (N-S) and the wall facing north overlooking (E-W) street. The ratios ($H2/H1$) are 0.2, 0.4, 0.8, 1.2, 1.6, 2.0, 2.4, 2.8 and 3.2. It is evident in figure (4.25) that the canyon asymmetry has a great impact in increasing solar radiation on façades overlooking asymmetric streets with $(H2/H1) < 1$ and reducing solar radiation on façades overlooking streets with $(H2/H1) > 1$ in comparison to incident solar radiation falling on façades overlooking symmetric street $H/W = 2$. Basically, incident solar radiation decreases with the increase of $H2/H1$ ratio due to the increasing of shading potential. For more details, decreasing $H2/H1$ ratio from 1.0 to 0.2 in the summer months can increase the incident solar radiation on façades overlooking (N-S) by about 1.31%, 3.02% and 4.0% for $(H2/H1)$ equal to 0.8, 0.4 and 0.2 respectively.

While increasing H2/H1 ratio from 1.0 to 3.2 can decrease the incident solar radiation by about 4.01%, 6.52%, 9.68%, 12.74%, 14.01% and 14.02% for (H2/H1) equal to 1.2, 1.6, 2.0, 2.4, 2.8 and 3.2 respectively. In contrast, decreasing H2/H1 ratio from 1.0 to 0.2 for east-west oriented street axis can increase the incident solar radiation on façades by about 18.63%, 39.5% and 42.09% for (H2/H1) equal to 0.8, 0.4 and 0.2 respectively. This is attributable to the greater openness to the sky of the asymmetric street which allows to attract and keep a higher potential of solar radiation access. Moreover, increasing H2/H1 ratio from 1.0 to 3.2 can decrease the incident solar radiation by about 10.77%, 35.78%, 42.65%, 48.86%, 50.89% and 55.02% for (H2/H1) equal to 1.2, 1.6, 2.0, 2.4, 2.8 and 3.2 respectively, see figure (4.25). Incident solar radiation decreases with the increase of H2/H1 because the sun's rays coming laterally are blocked by the higher façades and lead to good thermal situation. In addition, the figures show clearly that the effectiveness of the asymmetry is increased for (E-W) street orientation. This strategy protect efficiently from undesirable solar radiation in the summer at the same time ensured more solar access in winter.

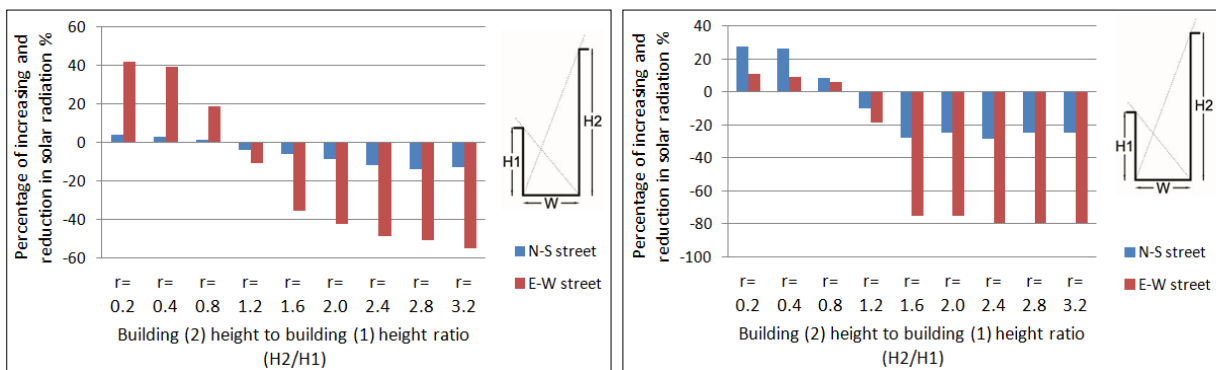

Figure (4.25): L: Percentage of increasing and reduction in incident solar radiation on façades overlooking (N-S) and (E-W) street as a result of canyon asymmetry in the summer months, R: in the winter months by ECOTECT.

With regard to the impact of canyon asymmetry along with orientation on the solar radiation falling on the area of streets. Figure (4.26) shows that asymmetry in street design has an effective and important role in increasing and reducing incident solar radiation percentage on the street according to façades height ratio. It is evident in figure (4.26) that solar radiation gradually increases on north-south oriented street axis with the decrease of (H2/H1) ratio and decreases with the increase of (H2/H1) ratio in comparison to incident solar radiation falling on symmetric street H/W=2 and H2/H1=1. For more clarity,

decreasing H2/H1 ratio from 1.0 to 0.2 in the summer months can increase the incident solar radiation on (N-S) street by about 6.14%, 34.32% and 59.15% for (H2/H1) equal to 0.8, 0.4 and 0.2 respectively. While increasing H2/H1 ratio from 1.0 to 3.2 can decrease the incident solar radiation by about 6.12%, 10.20%, 14.83%, 18.58%, 24.63% and 25.20% for (H2/H1) equal to 1.2, 1.6, 2.0, 2.4, 2.8 and 3.2 respectively. In contrast, decreasing H2/H1 ratio from 1.0 to 0.2 for east-west oriented street axis can increase the incident solar radiation on the street by about 5.57%, 20.01% and 30.05% for (H2/H1) equal to 0.8, 0.4 and 0.2 respectively. While increasing H2/H1 ratio from 1.0 to 3.2 can decrease the incident solar radiation on (E-W) street by about 4.34%, 11.26%, 22.98%, 28.89%, 36.97% and 43.10% for (H2/H1) equal to 1.2, 1.6, 2.0, 2.4, 2.8 and 3.2 respectively. It is clear that the percentage of increase in solar radiation falling on east-west oriented street axis is less than the percentage of increase in solar radiation falling on north south oriented street axis, as well as the percentage of decrease in solar radiation falling on the (E-W) street is more than the percentage of decrease in radiation falling on (N-S) street. On the other hand, the percentage of increase in solar radiation falling on (E-W) street is more than the percentage of increase in solar radiation falling on (N-S) street in the winter. So it can be concluded that asymmetry in (E-W) street is the most efficiently because it can reduce undesirable radiation and provide more shade at the street level in summer as well as promote solar access in winter.

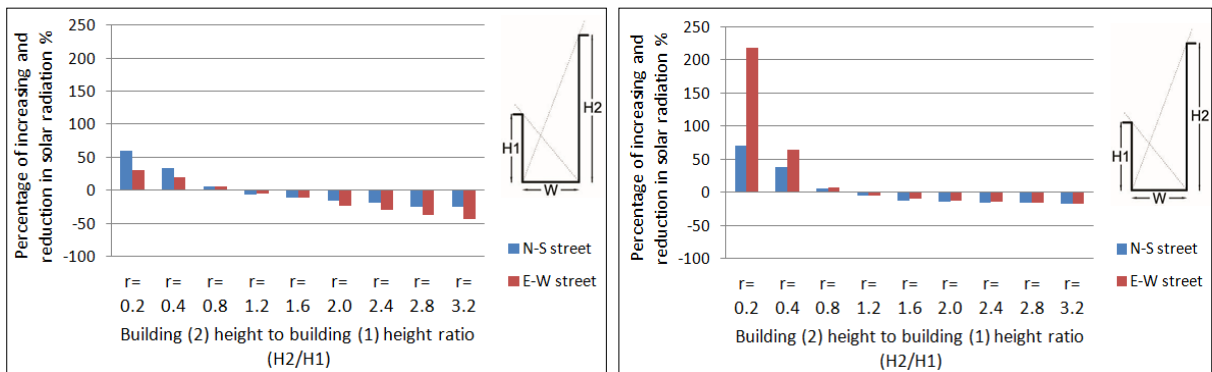

Figure (4.26): L: Percentage of increasing and reduction in incident solar radiation on (N-S) and (E-W) streets as a result of canyon asymmetry in the summer months, R: in the winter months by ECOTECT.

5. Effects of the overhanging facades

The simulated cases studied the impact of overhanging facades width to street width ratio on the amount of solar radiation falling on façades. Figure (4.27) shows percentage of

reduction in incident solar radiation on the wall facing east in (N-S) street and the wall facing south in (E-W) street including overhanging facades with different width (w') (different sky opening) and constant height (h). The overhanging facades is $0.1W$, $0.15W$, $0.2W$, $0.25W$, $0.3W$, $0.35W$, $0.4W$ and $0.45W$ wide. The results indicate that the façades with overhanging receives less amount of solar radiation in comparison to a symmetrical canyon with $H/W = 2$ (without overhanging). In addition, reduction in incident solar radiation for the simulated shapes are increased with increasing the overhanging width to street width ratio (w'/W) from 0.1 to 0.45. For more details, increasing the overhanging width from $0.1W$ to $0.45W$ in the summer months can decrease the incident solar radiation on the wall facing east which overlooks the north-south oriented street axis in ECOTECT by about 14.61%, 18.42%, 22.15%, 26.13%, 30.13%, 34.31%, 38.33 and 40.64% for width ratios (w'/W) equal to 0.1, 0.15, 0.2, 0.25, 0.3, 0.35, 0.4 and 0.45 respectively. While decrease the radiation in the winter months by about 30.62%, 32.37%, 35.57%, 38.14%, 42.12%, 46.17%, 50.68% and 55.55%. In IDA ICE software, about 19.54%, 24.15%, 28.25%, 32.25%, 36.48, 40.24%, 44.12% and 47.21% of decreasing in the solar radiation for the same ratios in the summer months. While about 34.15%, 37.15%, 40.55%, 43.95%, 47.91%, 52.54.05%, 57.56% and 63.15% in the winter months, see figure (4.28). It is noticed that the exposure of the walls to the solar radiation is less in the largest width of overhanging and thus it is more shaded. Balconies and inclined façades can contribute efficiently in reducing solar radiation and increasing the shading on the façades, so it is recommended to pay special attention.

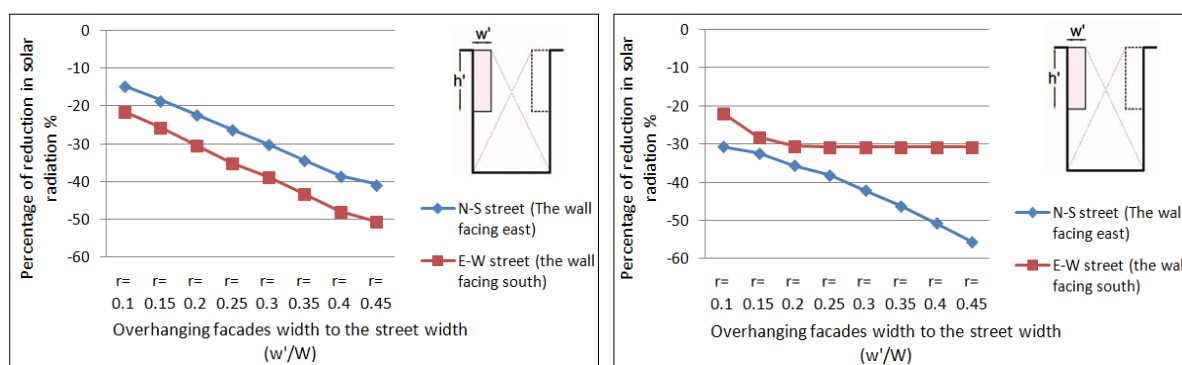

Figure (4.27): L: Percentage of reduction in incident solar radiation on façades overlooking (N-S) and (E-W) street as a result of varying the overhanging facades width in the summer months, R: in the winter months by ECOTECT.

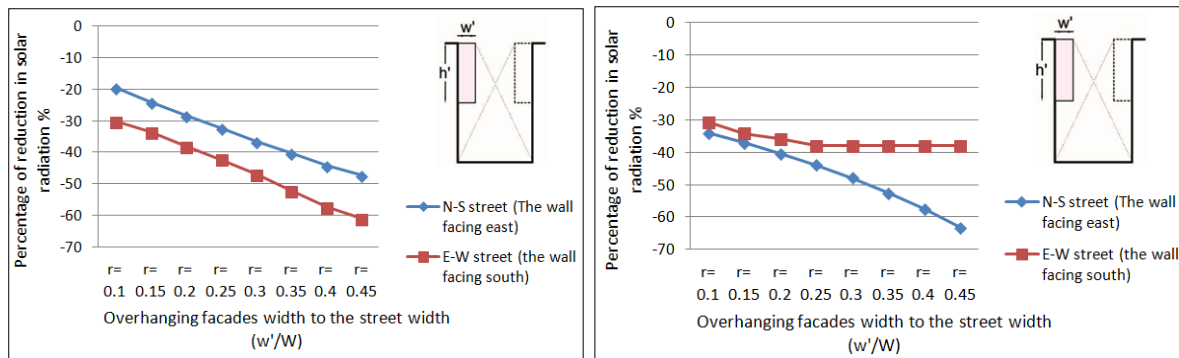

Figure (4.28): L: Percentage of reduction in incident solar radiation on façades overlooking (N-S) and (E-W) street as a result of varying the overhanging facades width in the summer months, R: in the winter months by IDA.

Moreover, figure (4.27) shows that the street orientation has an appreciable effect on reducing incident solar radiation percentage. For more details, changing the street orientation from the north- south to the east- west can decrease solar radiation during the summer months by about 21.46%, 25.55%, 30.36%, 35.04%, 38.66%, 43.14%, 47.83% and 50.49% in the case of width ratios (w'/W) equal to 0.1, 0.15, 0.2, 0.25, 0.3, 0.35, 0.4 and 0.45 respectively. However, the percentage of decreasing in the solar radiation for these eight ratios in IDA ICE are 30.15%, 33.55%, 38.02%, 42.15%, 46.92%, 52.12%, 57.21% and 60.86% respectively, see figure (4.28). So overhanging facades design in the wall facing south in (E-W) streets orientation is more effective in reducing incident solar radiation percentage in summer.

Similarly, the overhanging facades affect the amount of solar radiation falling on the streets ground. Figure (4.29) shows that overhanging facades have an important role in reducing incident solar radiation falling on the street due to the offset of the façades over it. It is evident in figure (4.29) that solar radiation gradually decreases on east-west oriented street axis with the increase of (w'/W) ratio in comparison to incident solar radiation falling on symmetric street H/W=2. For more clarity, increasing w'/W ratio from 0.1 to 0.45 can decrease the incident solar radiation falling on (E-W) street in the summer months by about 4.89%, 7.31%, 11.83%, 17.26%, 22.21%, 27.45%, 33.32% and 40.89% for (w'/W) equal to 0.1, 0.15, 0.2, 0.25, 0.3, 0.35, 0.4 and 0.45 respectively. While it decreases the incident solar radiation in the winter months by about 5.45%, 8.33%, 11.21%, 14.47%, 17.54%, 21.25%, 24.81% and 28.29%. It is worthy of note that overhanging facades design in street canyon more effective in reducing solar radiation falling on façades as well as streets than galleries design in comparison to a symmetrical canyon with H/W = 2. Overhanging

facades show an appreciable amelioration in solar radiation situation in summer by reducing undesirable sun rays.

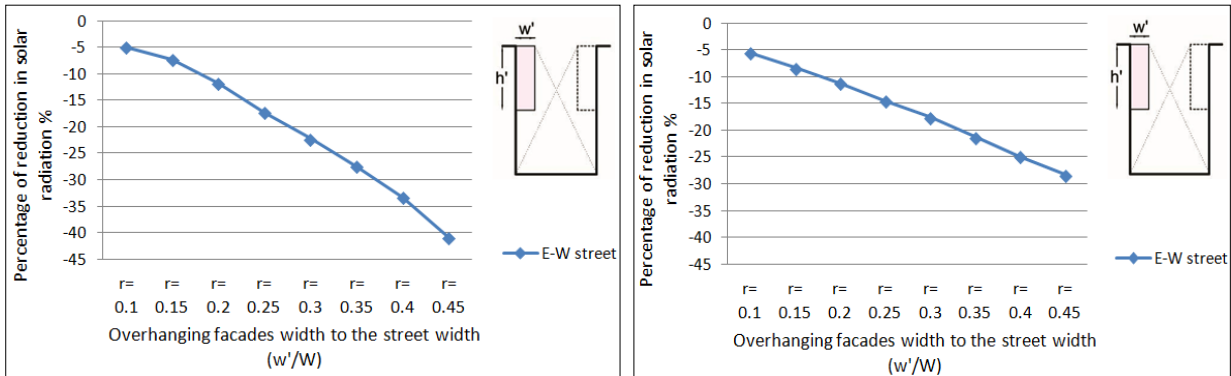

Figure (4.29): L: Percentage of reduction in incident solar radiation on (E-W) street as a result of overhanging facades design in the summer months, R: in the winter months.

6. Effects of Vegetation

Figure (4.30) shows the percentage of reduction in incident solar radiation falling on the wall facing east for a N-S oriented street of $H/W = 2$ including rows of different numbers of trees and different locations. It is evident in figure (4.30) that reduction in solar radiation gradually increases with the increase of trees number in comparison to street without trees. Moreover, the percentage of reduction in solar radiation when trees located on western pavement in summer is higher than centralized island and eastern pavement. For more details, increasing the number of trees from 3 to 24 trees on western pavement can decrease the incident solar radiation on the wall facing east which overlooks the north-south oriented street axis in the summer months by about 0.58%, 1.54%, 3.15%, 4.55%, 6.31%, 8.09%, 9.74 and 11.85% for trees number equal to 3, 6, 9, 12, 15, 18, 21 and 24 respectively. While it decreases the incident solar radiation in the winter months by about 0.16%, 0.91%, 1.87%, 3.16%, 4.26%, 5.29%, 6.5% and 7.85%. Changing trees locations from western pavement to centralized island can decrease the incident solar radiation in the summer only by about 0.05%, 0.08%, 0.3%, 0.6%, 0.75%, 0.9%, 1.1 and 1.2%. Changing trees locations to eastern pavement does not affect the amount of solar radiation falling on the wall facing east because trees is far from it. It can be concluded that the planted street with a higher number of trees and close to façade is the most effective in promoting more shade and thus reducing the amount of undesirable radiation falling on the façade in summer. Therefore, it is recommended to take into account the number of trees and the actual distance between trees and facades.

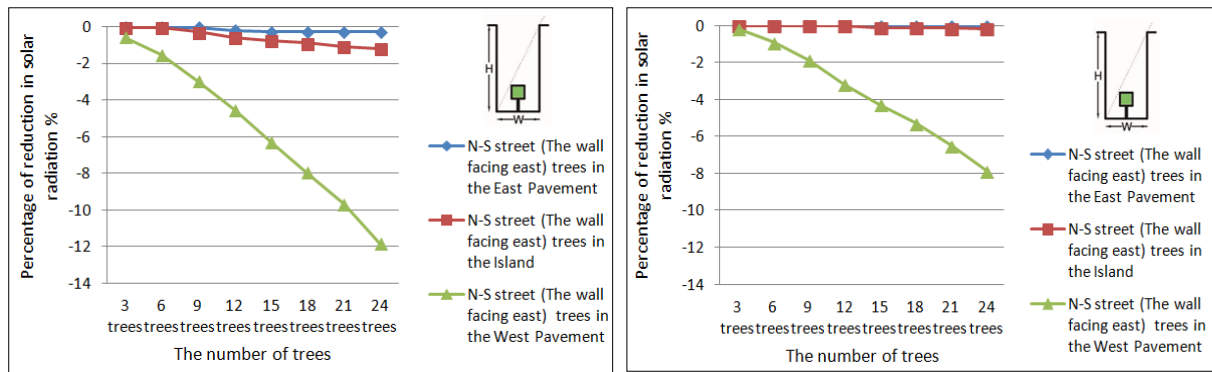

Figure (4.30): L: Percentage of reduction in incident solar radiation on façades overlooking (N-S) street as a result of streets planting in the summer months, R: in the winter months.

With respect to orientation, figure (4.31) shows that the street orientation with planting has an important effect on reducing the amount of incident solar radiation. For more details, changing the street orientation from the north- south to the east- west when trees located on northern pavement can decrease solar radiation falling on the wall facing south which overlooks the east-west oriented street axis in the summer months by about 1.35%, 4.37%, 6.05%, 8.21%, 10.35%, 12.23, 13.51% and 14.24% in the case of trees number equal to 3, 6, 9, 12, 15, 18, 21 and 24 respectively. While it decreases the incident solar radiation in the winter months by about 0.21%, 0.39%, 0.64%, 0.90%, 1.16%, 1.45%, 1.70% and 1.89%. It is noticed that the percentage of reduction in solar radiation falling on in the wall facing south in (E-W) streets orientation in the winter months is less than the percentage of reduction in radiation falling on the wall facing east in (N-S) streets orientation. Thus, (E-W) streets orientation keep a higher potential of desirable solar access in winter. The graphs also shows that changing trees locations from northern pavement to centralized island and southern pavement have not a significant effect on the amount of solar radiation. This suggests that planting on street edges would be preferable for further protecting the sidewalks and facades.

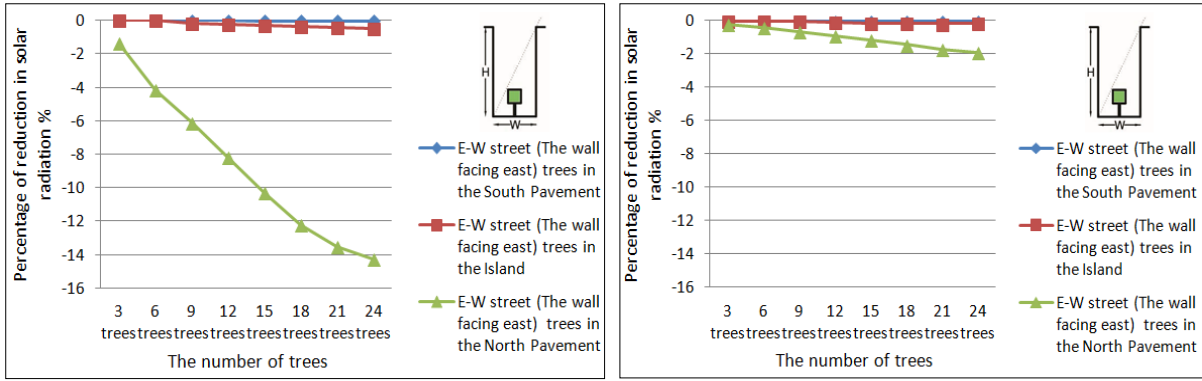

Figure (4.31): L: Percentage of reduction in incident solar radiation on façades overlooking (E-W) street as a result of streets planting in the summer months, R: in the winter months.

On the other hand, the use of trees affect the amount of solar radiation falling on the streets. Figure (4.32) shows that streets planting have an effective role in reducing incident solar radiation falling on the street due to shading at the street level by trees. It is evident in the figure that solar radiation gradually decreases on east-west oriented street axis with the increase of the number of trees in comparison to incident solar radiation falling on street without trees. For more details, increasing the number of trees from 3 to 24 on centralized island can decrease the incident solar radiation falling on (E-W) street in the summer months by about 2.02%, 15.28%, 22.07%, 26.75%, 31.24%, 35.66%, 37.76% and 39.02% for trees number equal to 3, 6, 9, 12, 15, 18, 21 and 24 respectively. While it decreases the incident solar radiation in the winter months by about 0.74%, 8.69%, 15.17%, 20.28%, 25.06%, 28.40%, 30.53% and 30.83%. It is worthy of note that, the percentage of reduction in solar radiation falling on streets with trees on centralized island is more than the percentage of reduction in solar radiation falling on streets with trees on southern pavement or northern pavement. This is because trees on centralized island cast its shadow on streets in contrast to trees on north pavement which falls its shadow on the walls facing south in (E-W) street and a little amount of shade cast on the street level.

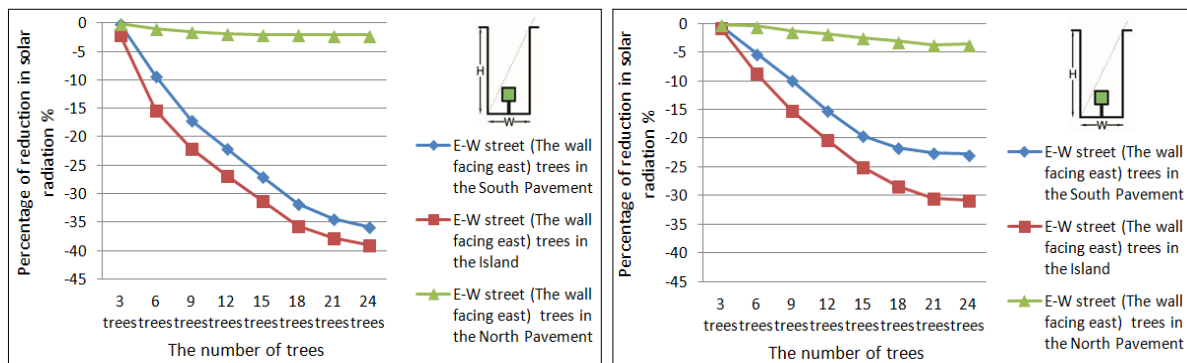

Figure (4.32): L: Percentage of reduction in incident solar radiation on (E-W) street as a result of streets planting in the summer months, R: in the winter months.

7. Geometric shape of the street

Figure (4.33) shows the incident solar radiation on façades overlooking different shapes of streets for a symmetrical canyon with $H/W = 2$. The results indicate that façades overlooking curved street receives the largest amount of solar radiation while façades overlooking plover street receives the least. For more details, incident solar radiation falling on the walls facing east in (N-S) streets orientation in the summer reaches to about 39.61 kwh/m², 38.75 kwh/m² and 26.329 kwh/m² for curved street, straight street and plover street respectively. It is worth mentioning that façades overlooking curved street receives the largest amount of solar radiation as a result of the mutual distribution of the buildings on both sides of the curved street which allows sunlight to reach the facades overlooking the street and thus reduces the amount of shading. In contrast, more shade were provided at the façades overlooking plover street and thus a less amount of undesirable radiation. So it can be concluded that plover street is more preferable geometric shape for the façades overlooking street. The graphs also shows that the difference is not noticeable between the amount of incident solar radiation on façades overlooking straight and curved streets. So it needs more architectural elements to reduce desirable solar radiation in summer. Similarly, in the winter months curved street receives the largest amount of solar radiation and the plover receives the least. For more details, incident solar radiation falling on the walls facing east in (N-S) streets orientation reaches to about 20.97 kwh/m², 18.12 kwh/m² and 11.64 kwh/m² for curved street, straight street and plover street respectively, see figure (4.33).

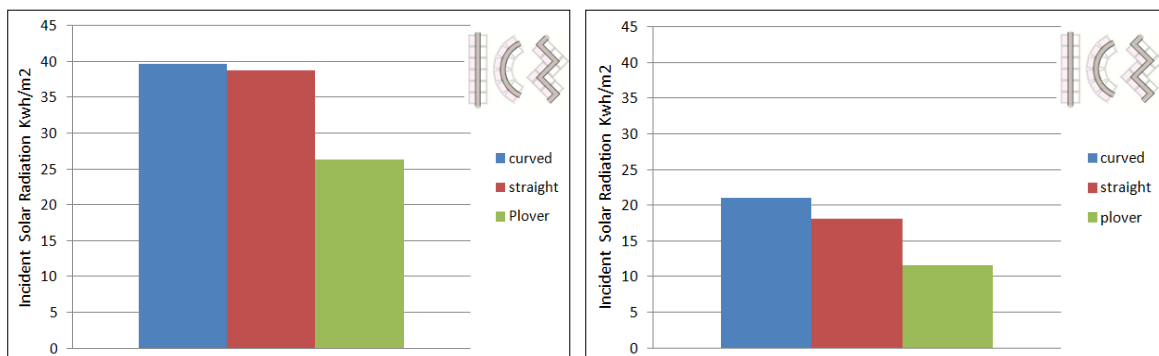

Figure (4.33): L: Incident solar radiation on façades overlooking different shapes of streets in the summer months, R: in the winter months.

With regard to the impact of geometric shape of streets on the solar radiation falling on the area of streets. Figure (4.34) shows that curved street receives the largest amount of solar radiation while the straight street receives the least. For more clarity, incident solar

radiation falling on (N-S) streets orientation in the summer months reaches to about 96.72 kwh/m², 76.41 kwh/m² and 92.08 kwh/m² for curved street, straight street and plover street respectively. On the other hand, straight street receives the largest amount of solar radiation and the plover receives the least in the winter months. For more details, incident solar radiation falling (N-S) streets orientation reaches to about 22.07 kwh/m², 24.02 kwh/m² and 18.60 kwh/m² for curved street, straight street and plover street respectively.

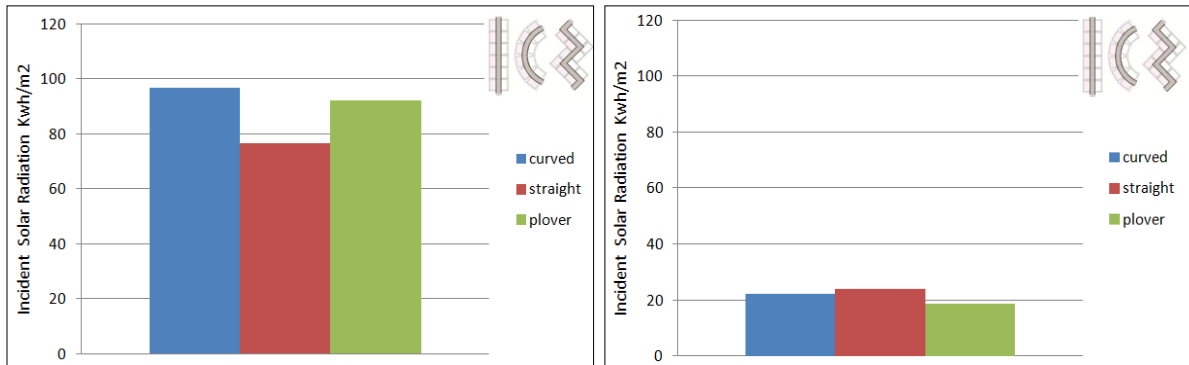

Figure (4.34): L: Incident solar radiation on different shapes of streets in the summer months, R: in the winter months.

4.3 Conclusion

This chapter discussed the impact of street geometry on the incident solar radiation. In particular, it studied seven parameters which are aspect ratio (H/W), street orientation, galleries, asymmetry, overhanging facades, vegetation and geometric shape of the street. Streets are simulated in the climatic conditions of the Gaza strip using ECOTECH and IDA ICE. It was concluded that the street geometry can affect efficiently the solar potential on the buildings facades and the mutual shading from the opposite buildings.

The study emphasized that the building height have to be determined to provide a large aspect ratio (H/W) especially in the north- south street. It was found that the deepest canyons with H/W of 4.0 can reduce undesirable radiation falling on the facade in summer by about 130.2% compared to aspect ratio H/W=0.5. Also, the long axis of the building should be elongated along the east-west direction. In addition, the chapter presented the impact of the gallery dimensions. It was concluded that deeper and lower galleries can play important role in reducing the incident solar radiation especially on the walls facing south which are the most important to shade. It was found that the deepest gallery with width ratios (w/W) =1.4 can reduce undesirable radiation falling on the façade by about 28.6%

and 46.74 for N-S and E-W streets respectively. Increasing the opposite building heights ratio affects significantly the incident solar radiation. Overhanging facades design with a small opening to the sky is more effective in reducing incident solar radiation than galleries, and thus completely covered street is preferable. Also, the locations and the densities of trees rows can affect the incident solar radiation. On the other hand, the study confirmed that plover street is more preferable as it can reduce undesirable radiation on the facades by about 33.52% in comparison with straight street.

Chapter 5: The Effect of Streets Morphology on the Thermal Performance of Buildings

5.1 Introduction

The previous chapter concentrated on studying the effects of different streets configurations on the incident solar radiation falling on facades, which overlooks the streets without clarifying the impact on the thermal response for the indoor environment of the residential buildings. It was confirmed that shading achieved by means of high aspect ratios, which found to be an effective strategy in shortening the duration of exposure to solar radiation. Also, it was observed that the E-W orientation is the most comfortable and N-S oriented street is more stressful. In addition, streets design details which are galleries, asymmetry and overhanging facades can reduce substantially the solar radiation falling on facades.

This chapter is carried out to study the impact of streets configurations on the thermal performance of the building as well as on the energy consumption. This study addresses the contribution of street design toward the development of a comfortable indoor environment at buildings level for occupants. It mainly focuses on the effects of street geometries including various aspect ratios and street orientation together with the role of architectural details such as galleries, horizontal overhangs on façades, asymmetry and geometric shapes of the street on the heating, cooling and total loads. Moreover, the analysis focuses on the spatial differences in the thermal sensation throughout the building envelope, i.e. building floors and floors apartments, which influence the frequentation of the building taking into account that window to walls ratio (WWR) equals 10%, which represents one of the common percentages of windows to walls ratios in Gaza. The investigation is carried out using IDA Indoor Climate and Energy (IDA ICE), which simulates the indoor environment changes by calculating total requirements of the energy. Comparison of the obtained results is performed to find which one requires less total loads during the year and thus reduces the energy demand.

As previously mentioned, there are several parameters related to thermal performance analysis. These parameters include simulation tools, climate data and building parameters which are assumed to be fixed to evaluate the effect of streets morphology on the energy demand for indoor environment. The same parameters that are described in the previous

chapter will be taken into account in this chapter. On the other hand, streets geometry parameters will be discussed in more details in the following sections.

5.2 Urban Street Geometry

The study focused on the effect of the urban street geometry and orientation on the thermal performance of the building and thus on the energy consumption (by calculating heating and cooling loads).

5.2.1 Parametric Investigation

A number of street geometries were selected to investigate its effects on the thermal performance of the building. The following are the parameter combinations investigated in the study.

- **Aspect Ratio (H/W):** Symmetrical urban canyons with H/W equal to 1, 2, 3 and 4 for N-S orientation were investigated. The block consists of twelve buildings with constant height (20 m), see table (5.1).

Table (5.1): The urban canyon parameters investigated in the study

Horizontal Plan	
Elevation	
Aspect ratio (H/W)	
4.0	3.0

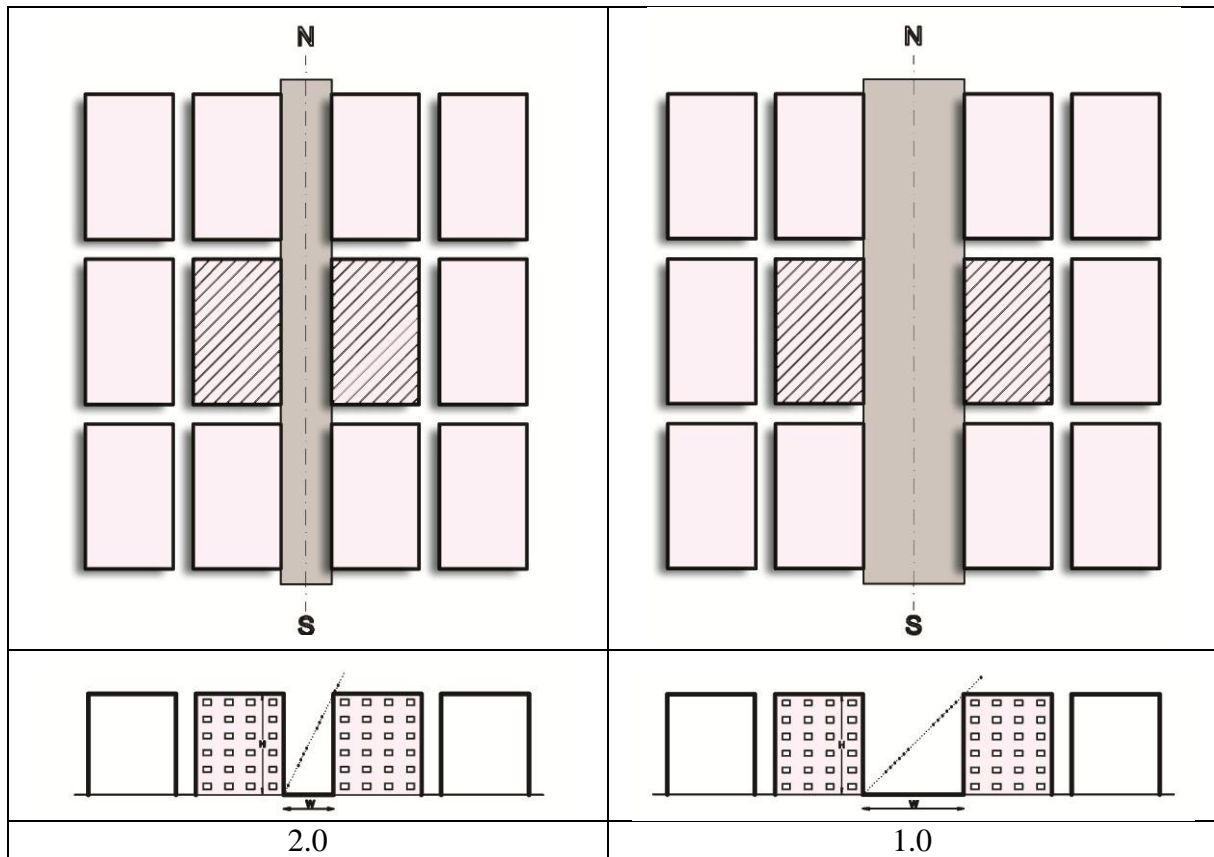

- **Street Orientation:** Seven values of orientations for $H/W = 4$ – which achieves the best thermal situation – were considered. Figure (5.1) shows these values which are $0^\circ E$, $15^\circ E$, $30^\circ E$, $45^\circ E$, $60^\circ E$, $75^\circ E$ and $90^\circ E$ (N-S).

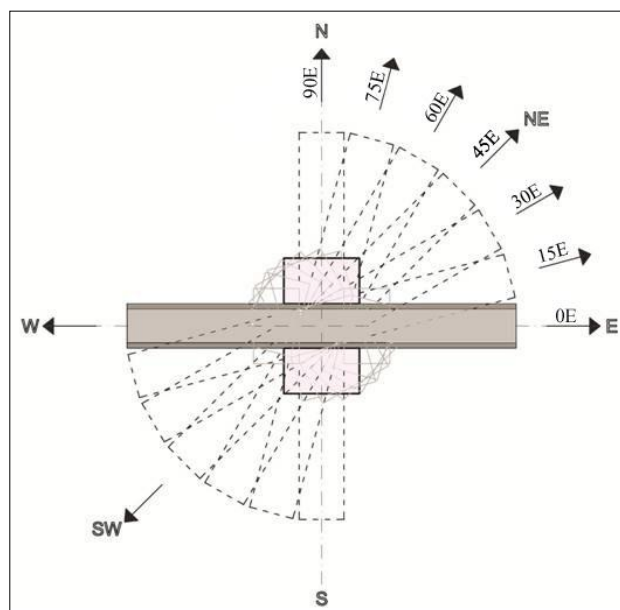

Figure (5.1): The seven values of street's orientation considered in the study

- **Galleries:** An urban canyon of $H/W = 4$ with different galleries depth and height were studied in block consists of six buildings. Four values of gallery width were simulated which are 0.5m, 1.0m, 1.5m and 2.0m. In addition, a gallery width equal to 2.0m were simulated, taking into consideration a variable gallery height. Five values of gallery height were considered, which are 1 floor (3.3m), 2 floors, 3 floors, 4 floors and 5 floors, see figure (5.2).

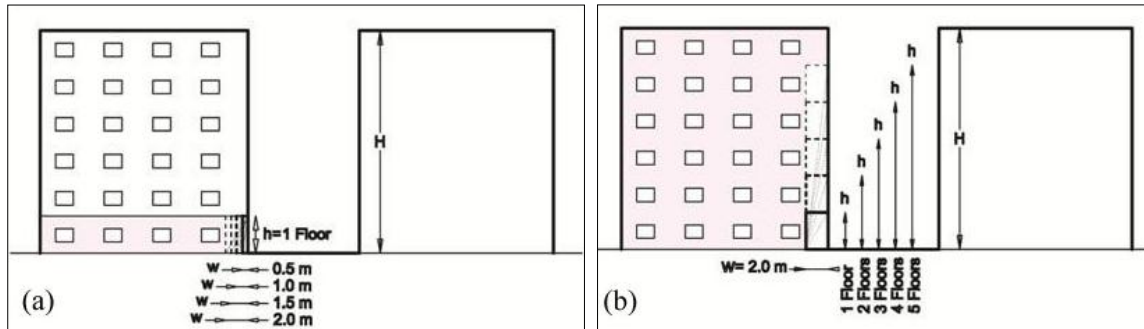

Figure (5.2): L: Four values of gallery width simulated in the study, R: Five values of gallery height considered

- **Asymmetry:** Asymmetrical urban canyon with a street of a constant width were studied. Five values of building (2) height were considered to study its impact on the thermal performance of building (1). Values of building (2) height equal to (studied building height + 1 floor), + 2 floors, + 3 floors, + 4 floors and + 5 floors, see figure (5.3).

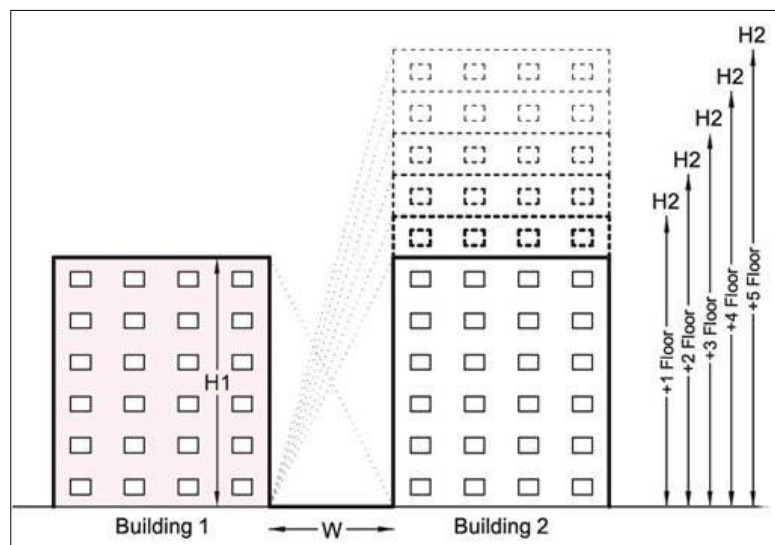

Figure (5.3): Five values of building (2) height simulated in the study.

- **Overhanging facades:** A symmetrical urban canyon including overhanging facades (starts from the first floor) were considered. The study simulated four values of overhanging facades width, which are 0.5m, 1.0m, 1.5m and 2.0m. In addition, gradual overhanging facades (0.5m for each floor) were simulated, see figure (5.4).

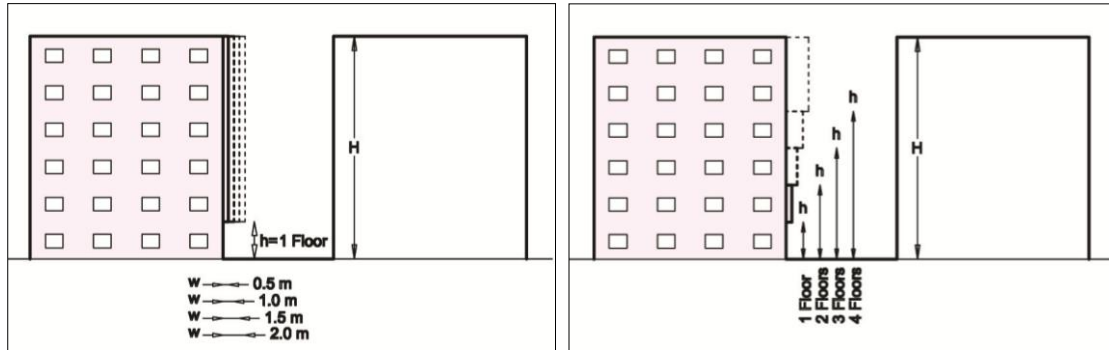

Figure (5.4): L: Four values of overhanging facades width considered in the study, R: gradual overhanging facades (0.5m for each floor)

- **Geometric shape of the street**

The three main geometric shape of streets which were investigated in the study are straight street, curved street and plover street to compare the thermal performance of the buildings overlooking these streets, see figure (5.5).

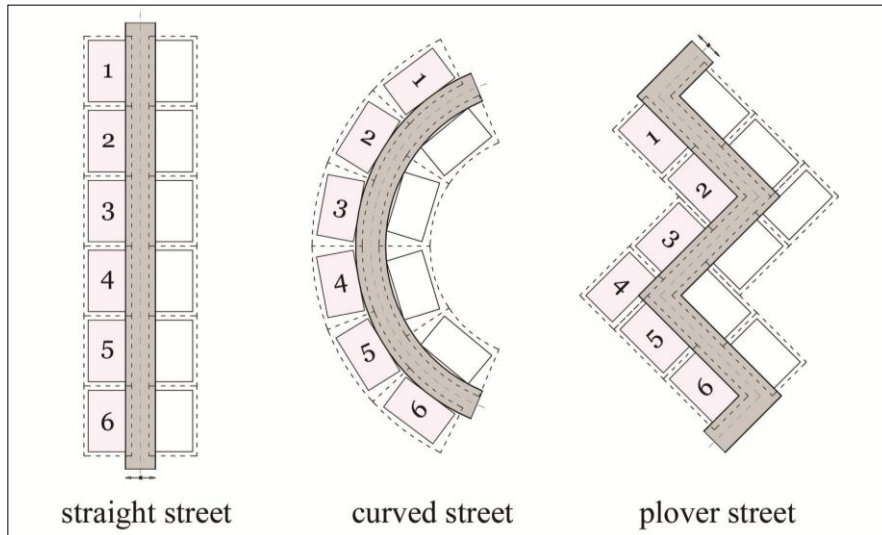

Figure (5.5): The three main geometric shape of streets simulated in the study

The output data of simulation will be discussed in more details in the following sections.

5.2.2 Discussion of results

The simulation results were expressed in terms of the thermal performance of buildings overlooking the street (in KWH/m³). The following sections discuss the results of IDA Indoor Climate and Energy (IDA ICE) program in order to select the optimum design.

1. Effect of Aspect Ratio (H/W)

Figure (5.6) shows the cooling and heating loads of central building overlooking the street during the year for symmetrical urban canyons oriented N-S with aspect ratios H/W varying from 1.0 to 4.0. Basically, cooling loads increase with the decrease of the aspect ratio due to the intense solar irradiation which increases the cooling requirements. For more details, decreasing the aspect ratio from 4.0 to 1.0 in the summer period (which means increasing the street width from 5.0 m to 20.0 m) can increase the cooling loads from 4.57 KWH/m³ to 5.14 KWH/m³ (by about 2.38%, 6.62% and 13.13% for aspect ratios H/W 3.0, 2.0 and 1.0 respectively). It is worthy of note that the deepest canyon with H/W = 4 achieves high comfortable conditions throughout the summer period, whereas the shallowest canyon with H/W = 1 achieves high uncomfortable conditions due to the exposure to the sun rays coming from the east direction combined with the daily maxima of air temperatures in summer. Thus, it needs more shading strategies in order to adjust to a stressful climatic situation. In contrast, decreasing the aspect ratio from 4.0 to 1.0 in the winter can decrease the heating loads from 5.90 KWH/m³ to 5.59 KWH/m³ (by about 5.27%). So a smaller aspect ratio is desirable for reducing the heating loads. Figure (5.6) shows the effect of decreasing the aspect ratio on the cooling loads in the summer as well as on the heating loads in the winter.

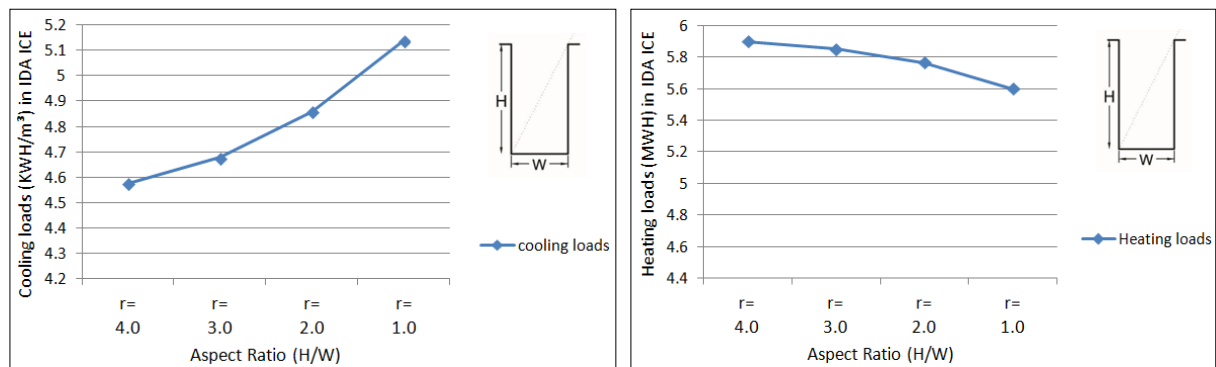

Figure (5.6): L: Cooling loads in north-south oriented street axis by IDA ICE, R: Heating loads.

The Graphical representation shown on figure (5.7) has the advantage of giving a complete picture of the total loads which privileged in accurate description for the thermal situation at building level. It is evident in the figure that the total loads trend, as expected, has the same trend of cooling loads. This is due to the intense solar irradiation in sunny days in comparison to the light sun rays in the winter. For more clarity, decreasing the aspect ratio from 4.0 to 1.0 can increase the total loads by about 2.59%. It is concluded that the deepest canyon with $H/W = 4$ is the most preferable option in the (N-S) street which can be applied in the Gaza Strip, where it can play an important role in reducing the total loads.

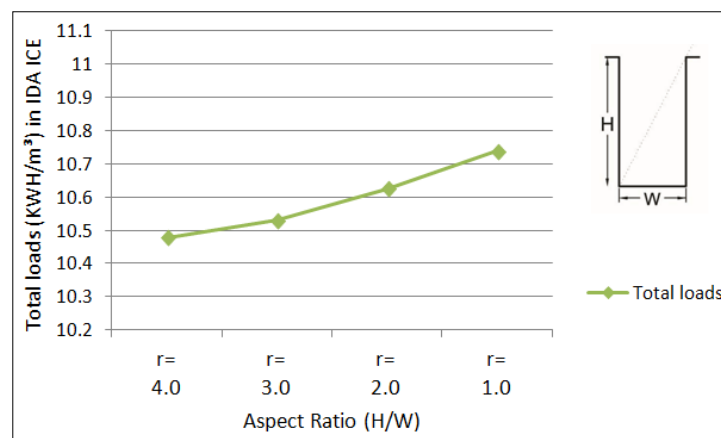

Figure (5.7): a: Total loads in (N-S) oriented street axis by IDA ICE.

In addition, the thermal performance was analyzed for three floors types. The graphs given in figure (5.8) represents cooling and heating loads in the ground, middle and upper floors for north-south oriented street axis with $H/W = 4, 3, 2$ and 1 respectively. This can be seen as an alternative for the building occupants to choose less stressful floors. The results indicate that the upper floors brings minimal improvements compared to the ground floors and the upper floors has a bad behavior for various aspect ratios throughout the summer periods due to the increasing in the solar radiation falling on the buildings roofs. In contrast, the ground floor has a better behavior. This is attributable to the effectiveness of adjacent buildings shading and also to the floor thermal behavior. Moreover, the shallowest canyon with $H/W=1$ has the worst behavior for the three floor types, but the deepest has the best due to the shorter time of exposure of its surfaces which results in a lower amount of radiant heat transfer. For more details, decreasing the aspect ratio from 4.0 to 1.0 in the summer period can increase the cooling loads from 0.023 KWH/m^3 to

0.052 KWH/m³ in the ground floor, from 0.26 KWH/m³ to 0.31 KWH/m³ in the middle floor, from 0.41 KWH/m³ to 0.43 KWH/m³ in the upper floor. The main reason is the lack of shading on the upper floor. So it is recommended to pay more attention to the upper floor in order to provide more shaded areas of the building roofs to ensure comfortable conditions. On the other hand, decreasing the aspect ratio from 4.0 to 1.0 in the winter period can decrease the heating loads from 0.87 KWH/m³ to 0.84 KWH/m³ in the ground floor, from 0.96 KWH/m³ to 0.89 KWH/m³ in the middle floor and from 1.04 KWH/m³ to 1.0 KWH/m³ in the upper floor. So it is concluded that decreasing the aspect ratio greatly increased the cooling loads for three floors types and slightly decreases the heating loads in the north-south oriented street axis due to the low altitude position of the sun in the winter periods, see figure (5.8).

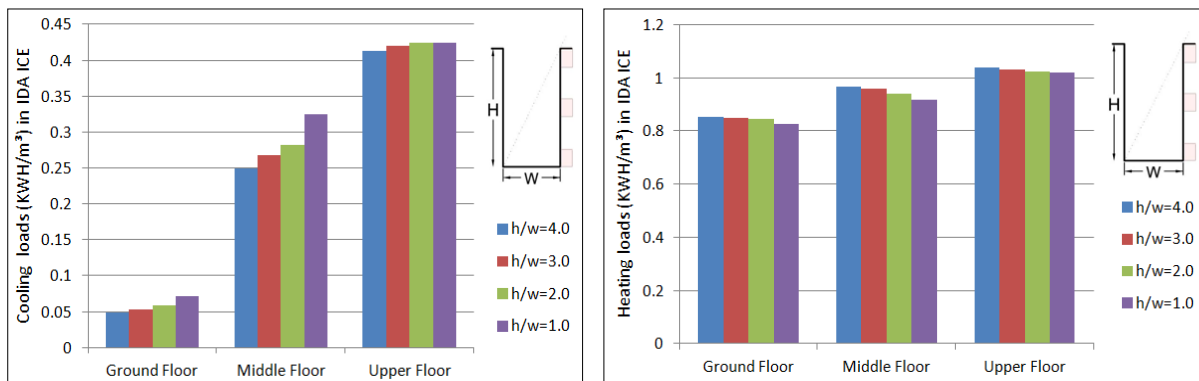

Figure (5.8): L: Cooling Loads in the ground, middle and upper floor in (N-S) street by IDA ICE, R: Heating loads

As shown in figure (5.9), the total loads of the three floors types take the same trend of the cooling loads. For more clarity, decreasing the aspect ratio from 4.0 to 1.0 can increase the total loads from 0.90 KWH/m³ to 0.91 KWH/m³ in the ground floor, from 1.21 KWH/m³ to 1.24 KWH/m³ in the middle floor and from 1.44 KWH/m³ to 1.46 KWH/m³ in the upper floor. It is noticed that the upper floor experiences the highest thermal discomfort, but the ground floor provides the highest thermal comfort. So the lower floors are advisable to live in because it reduces the total loads and achieve a better thermal comfort.

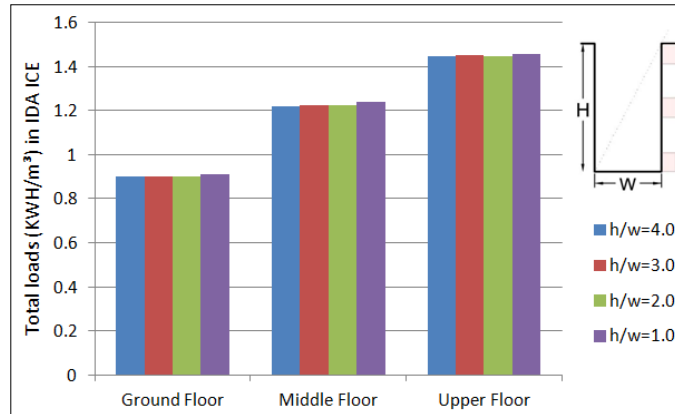

Figure (5.9): Total Loads in the ground, middle and upper floor in (N-S) street

As the narrower canyons with H/W of 4.0 provides the most improvement in the thermal situation and decreases the total requirements throughout the year. So it will be fixed at H/W = 4 for the following studies.

2. Effect of Street Orientation

The study compares the thermal performance of the two central buildings overlooking the street which are the building facing north (in E-W street) perverted toward west (in N-S street) and the building facing south (in E-W street) perverted toward east (in N-S street). The study takes into consideration a symmetrical streets with aspect ratio H/W = 4 which achieves the best thermal situation and protected from the sun all the day except shortly around noon especially in N-S street. The seven street orientation which are 0°E, 15°E, 30°E, 45°E, 60°E, 75°E, 90°E. It is evident in figure (5.10) that the street orientation has an important impact on increasing the cooling requirements in the summer period especially in north-south oriented street axis for the two central buildings overlooking the street. In contrast, the east-west oriented street axis reduced the cooling loads. This is due to the fact that an E-W orientation promotes strongly the effectiveness of the buildings shading. The graphs also shows that the building facing north (in E-W street) perverted toward west (in N-S street) has a bad behavior where it experiences the highest thermal discomfort and needs more cooling loads to achieve thermal comfort in comparison to the opposite building. This is attributable to the increase in solar radiation falling on façades of the building facing north perverted toward west as a consequence of the sun course. For more details, changing the street orientation from the north-south to the east-west orientation in the summer period can decrease the cooling loads for the building facing north perverted toward west by about 2.73%, 8.19%, 16.94%, 25.68%, 32.24% and 37.25% in the case of

street orientation which are 75°E, 50°E, 45°E, 30°E, 15°E and 0°E (E-W) respectively. While decrease the cooling loads for the building facing south perverted toward east by about 2.23%, 6.06%, 11.43%, 15.65%, 20.25% and 22.08% for simulated streets orientations, see figure (5.10). Hence, it is possible to minimize the bad behavior of the north- south streets especially for the building facing west by increasing the buildings facing east height so that more shading potential can be achieved. In contrast, the effect of changing the street orientation in the winter period is not remarkable, where the differences in the heating loads are very small between all orientations. This is not surprising due to the low path of the sun in the winter periods and the lack of solar radiation intensity.

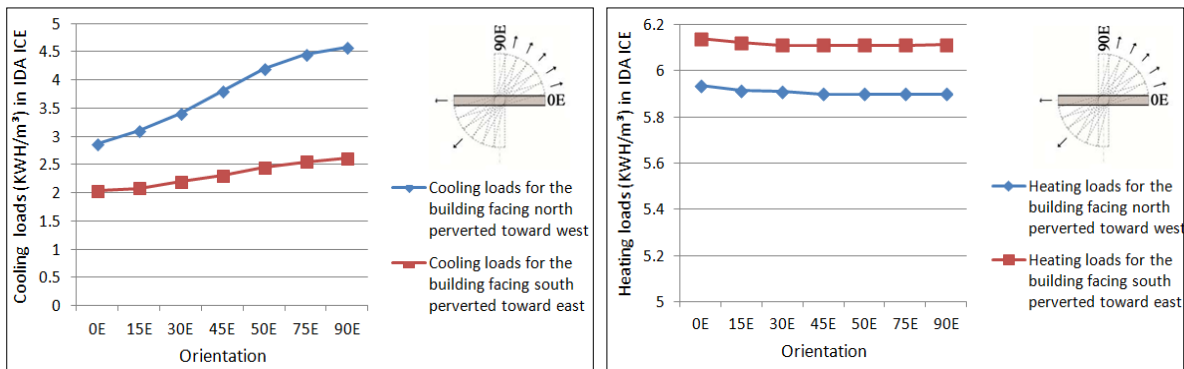

Figure (5.10): L: Cooling loads for H/W= 4 for the two buildings overlooking various orientations by IDA ICE, R: Heating loads.

With respect to the building facing north in (E-W) street which decreases the cooling requirements in the summer, figure (5.11) presents cooling and heating loads for three floors types which are the ground, middle and upper floor for this building with H/W = 4, 3, 2 and 1 respectively. The results shows that the upper floors remains highly uncomfortable for various aspect ratios in summer and winter periods. But the ground floor has a better behavior as a result of the effectiveness of adjacent buildings shading.

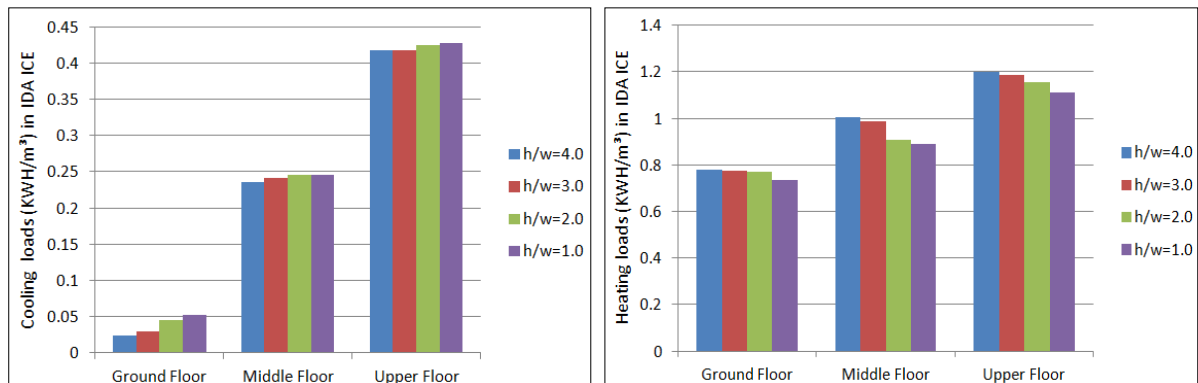

Figure (5.11): L: Cooling Loads in the ground, middle and upper floor in the building facing north in (E-W) street by IDA ICE, R: Heating loads

Moreover, the thermal performance was analyzed for four apartments orientation which are north- east apartment, north- west apartment, south- east apartment and the south- west apartment, see figure (5.12). The four apartment orientations were analyzed for three floors types for east-west oriented street axis with $H/W = 4$. This can be seen as an alternative for the floor occupants to choose a less stressful apartment and move to nearby less stressful areas.

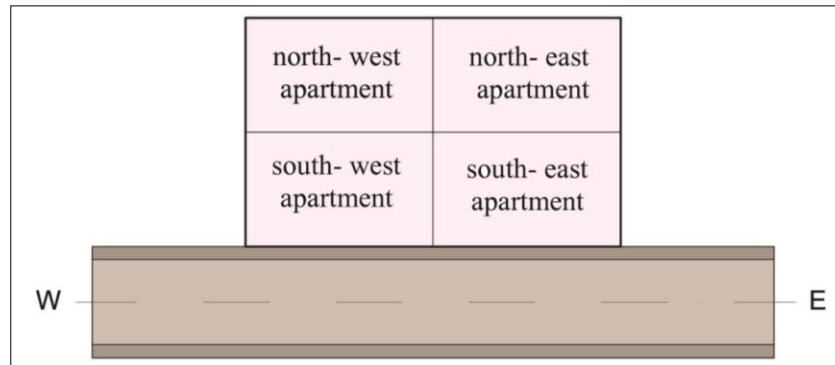

Figure (5.12): A four apartments orientation

The results indicate that the south- west apartment experiences the highest thermal discomfort for the various floors types in summer periods where it needs more cooling requirements to achieve thermal comfort due to the increasing of solar radiation falling on the wall facing south combined with the westerly sun exposure. The north- east apartment offers principally a better thermal situation due to the decreasing of solar radiation falling on the wall facing north. For more clarity, the cooling loads reaches to 0.0021KWH/m³, 0.0024KWH/m³, 0.021KWH/m³, 0.027KWH/m³ for the north- east apartment, north-west apartment, south-east apartment and the south-west apartment in the ground floor respectively. While reaches to 0.02KWH/m³, 0.03KWH/m³, 0.08KWH/m³, 0.09KWH/m³ for various apartment orientation in the middle floor respectively. And reaches to 0.06KWH/m³, 0.07KWH/m³, 0.12KWH/m³, 0.14KWH/m³ for various apartment orientation in the upper floor respectively. So it is recommended to exclude the long leisure activity in both areas (south-east and the south-west) unless improvements of the thermal quality based on further shading strategies are planned, e.g. higher aspect ratios or further shading devices such as trees, galleries, overhanging facades or asymmetry elevations. In contrast, the north- east apartment and the north- west apartment need more heating loads where they receive less beam irradiation during the winter. Generally, the differences in the heating loads are small in various apartment orientation see figure (5.13).

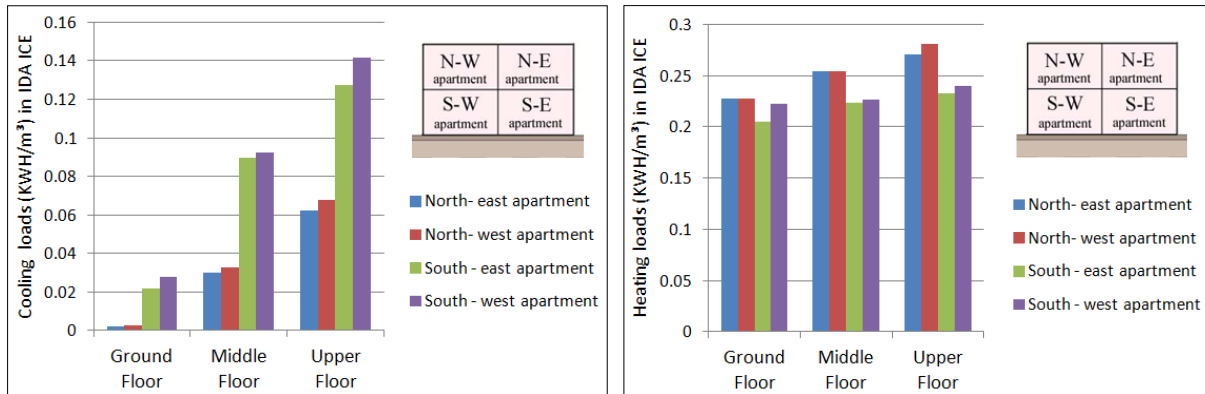

Figure (5.13): L: Cooling Loads in four apartments orientation in the building facing north in (E-W) street by IDA ICE, R: Heating loads.

As shown in figure (5.14), the total loads of the various apartment orientation take the same trend of the cooling loads. The results indicate that the south- west apartment has a bad behavior for the various floors types during the year because it is directly exposed to solar radiation. While the north- east apartment achieve a better thermal comfort. So it is recommended to pay more attention to the south- west apartment to be protected by shading devices to receive less amount of radiation especially in the summer.

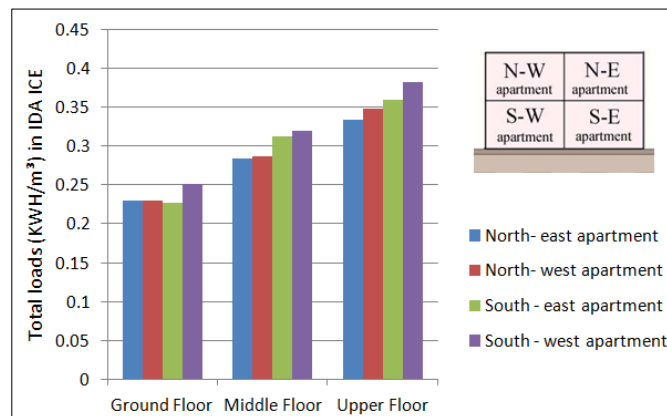

Figure (5.14): a: Total loads in four apartments orientation in the building facing north in (E-W) street

3. Effect of Galleries

The first case study is concerned with the impact of galleries width on the cooling and heating loads in the ground floor. Figure (5.15) presents percentage of reduction in the cooling loads and percentage of increasing in the heating loads – street canyon without galleries was taken as a reference case – in the ground floor in the building facing west in (N-S) street with aspect ratio $H/W = 4$ including galleries with different depth (w) and constant height (h). The gallery height is 1 floor (3.3m) and 0.5m, 1.0m, 1.5m and 2.0m wide. The results indicate that reduction in cooling loads for the simulated shapes of street

are increased with increasing the gallery width. This is attributable to the effectiveness of horizontal shading of the deeper galleries. For more details, increasing the galleries width from 0.5m to 2.0m can decrease the cooling loads in the ground floor in the building facing west in north-south oriented street axis in the summer by about 0.51%, 2.14%, 3.21% and 3.92% for galleries depth equal to 0.5m, 1.0m, 1.5m and 2.0m respectively. While increase the heating loads in the winter by about 0.44%, 0.79%, 1.46% and 2.0%. With respect to orientation, the figure also shows that the street orientation with galleries has a good effect on reducing the cooling loads. For more details, changing the street orientation from the north- south to the east- west can decrease the cooling loads in the ground floor in the building facing north in the summer by about 1.23%, 3.28%, 5.21% and 6.32% in the case of galleries depth equal to 0.5m, 1.0m, 1.5m and 2.0m respectively. While increase the heating loads in the winter by about 0.18%, 0.44%, 0.87% and 1.12%. This difference is not remarkable because the lower floors are already shaded. It is noticed that the decrease in the cooling loads in E–W street in the summer exceeds the decrease in N–S street. So galleries design in (E-W) streets orientation is more effective and sensitive in reducing the cooling loads percentage.

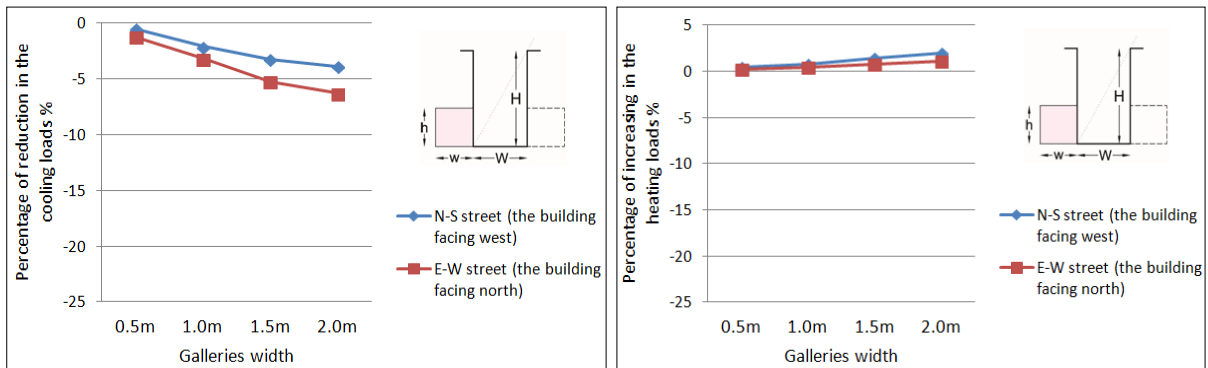

Figure (5.15): L: Percentage of reduction in the cooling loads in the building facing west in (N-S) street and the building facing north in (E-W) street as a result of varying the galleries width, R: Percentage of increasing in the heating loads

On the whole, the total loads in the ground floor, as expected, take the same trend of the cooling loads for both streets orientations, see figure (5.16). It is noticed that the deepest gallery with $w = 2.0$ m achieves the best thermal comfort and reduces energy consumption. Hence, it is possible to minimize the bad impact especially of the southern apartments overlooking (E-W) street orientation by increasing the width of gallery to get a

large amount of shading, suggesting that an alternative for occupants to stay in shade areas in southern apartments is available.

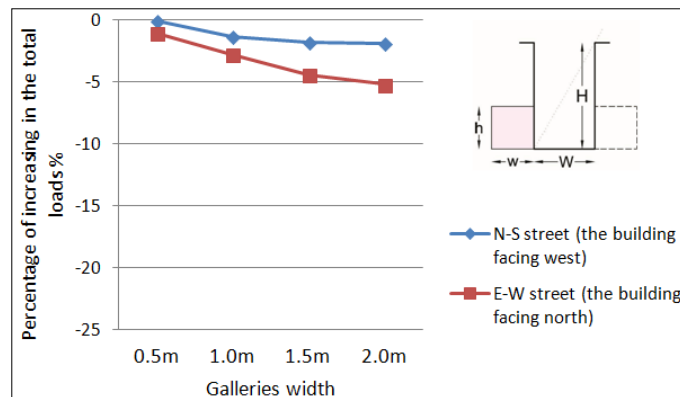

Figure (5.16): a: Percentage of reduction in the total loads as a result of varying the galleries width by IDA ICE.

The second case study is concerned with the impact of galleries height on the cooling and heating loads in all floors which includes the gallery. The simulated shapes have constant width of galleries and different galleries height (h) for N-S and E-W oriented street axis. The gallery width is 2m and 1 floor (3.3m), 2 floors, 3 floors, 4 floors and 5 floors height. The results indicate that the percentage of reduction in the cooling loads in the summer increased in higher floors which are located directly under the gallery. While the percentage of increasing in the heating loads in the winter slightly increased, see figure (5.17). For more clarity, the gallery height equals to 1 floor can decrease the cooling loads in north-south oriented street axis in the summer by about 3.92% in the ground floor. The gallery height equals to 2 floors can decrease the cooling loads by about 10.02% and 3.15% in the first floor and ground floor respectively. The gallery height equals to 3 floors can decrease the cooling loads by about 11.48%, 7.54% and 2.35% in the second floor, first floor and ground floor respectively. The gallery height equal to 4 floors can decrease the cooling loads by about 14.28%, 8.47% and 4.69% in the third floor, second floor and first floor respectively. But the gallery height equal to 5 floors can decrease the cooling loads by about 18.68%, 11.29% and 5.27% in the fourth floor, third floor and second floor respectively. However, these covered spaces also faces periods of low stress. This is due to an exposure of the lower floors facades and the ground surface to direct solar beam as well as the outgoing heat from the ground in the case of the higher galleries in spite of the relatively high aspect ratio. For more clarity, the gallery height equal to 4 and 5 floors can increase the cooling loads by about 1.05% and 1.53% respectively in the ground floor. So

it is concluded that, it is possible to reduce the cooling loads in the upper floors by high galleries which effectively reduce the cooling requirement in the covered floors directly. Hence, attention is drawn here on the appropriateness of galleries dimensions i.e. height and width for assessing thermal comfort within floors includes galleries.

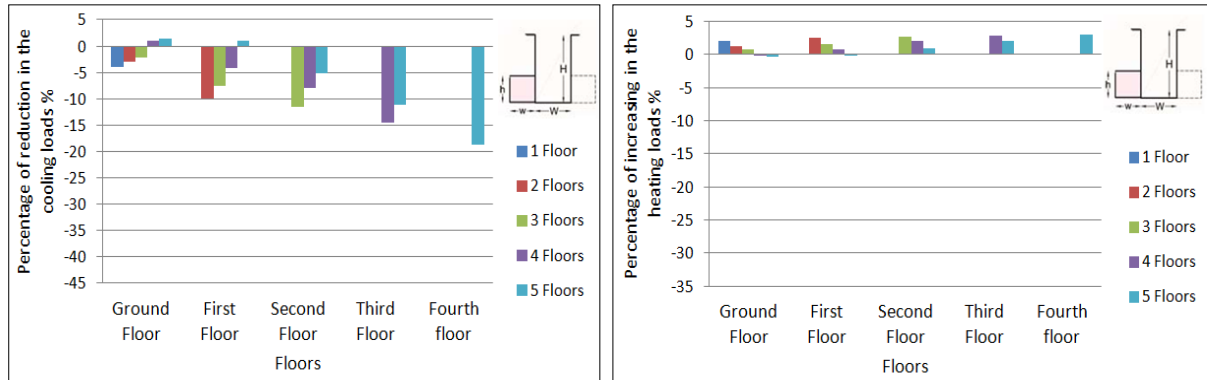

Figure (5.17): L: Percentage of reduction in the cooling loads in the building facing west in (N-S) street as a result of varying the galleries height, R: Percentage of in increasing the heating loads

With regard to the impact of orientation along with the gallery height, figure (5.18) shows that the street orientation with galleries has a significant effect on reducing the cooling loads and thus mitigation of thermal stress. Changing the street orientation from the north- south to the east- west can decrease the cooling loads in the summer period by about 6.32% in the ground floor in the case of the gallery height equal to 1 floor, by about 14.08% and 4.95% in the first floor and ground floor respectively in the case of the gallery height equal to 2 floors, by about 19.24%, 11.18% and 2.64% in the second floor, first floor and ground floor respectively in the case of the gallery height equal to 3 floors, by about 23.48%, 15.57%, 6.16% and 58.22% in the third floor, second floor and first floor respectively in the case of the gallery height equal to 4 floors and by about 29.57%, 17.38% and 8.24% in the fourth floor, third floor and second floor respectively in the case of the gallery height equal to 5 floors. The graphics also shows that the percentage of increasing in heating loads in (E-W) street is less than the percentage of increasing in (N-S) street, which confirms that the galleries in an (E-W) street are well protected and the extent of discomfort is very limited. So it is concluded that east- west oriented street axis with galleries effectively reduces the bad effect of undesirable radiation falling on the southern apartments especially in the summer at the same time keeps the desirable heat in the winter.

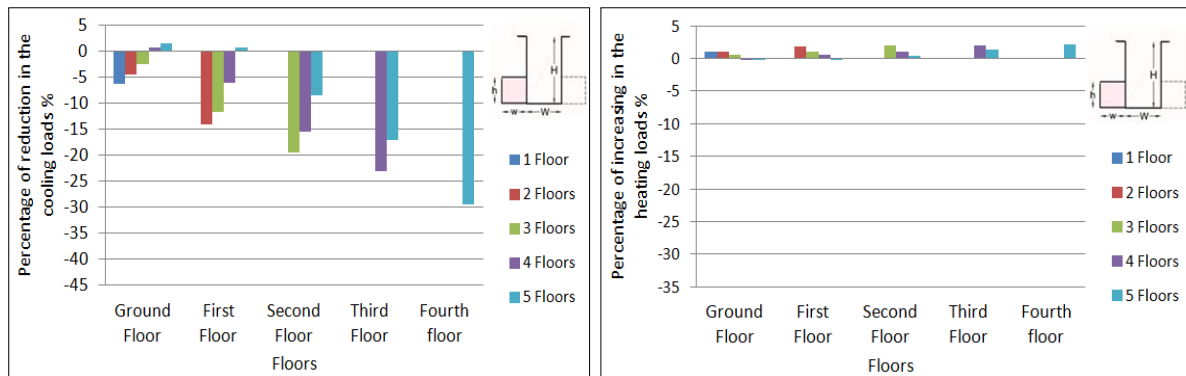

Figure (5.18): L: Percentage of reduction in the cooling loads in the building facing north in (E-W) street as a result of varying the galleries height by IDA ICE, R: Percentage of increasing in the heating loads.

4. Effects of the canyon Asymmetry

Figure (5.19) presents the percentage of reduction in the cooling loads and percentage of increasing in the heating loads in asymmetric streets ($H_1 \neq H_2$) – a symmetric street ($H_2 = H_1 = 20\text{m}$) with aspect ratio $H/W = 4$ was taken as a reference case – in the floors of building facing west in (N-S) street. This part is concerned with the impact of building (2) heights on the cooling and heating loads in building (1). Studied building height $H_1 = 20\text{m}$ (ground+5 floors). But building (2) height equal to ($H_1 + 1$ floor), + 2 floors, + 3 floors, + 4 floors and + 5 floors i.e. $H_2 > H_1$. It is evident in the figure that the canyon asymmetry has a good impact in decreasing the cooling loads in the floors of building facing west in (N-S) street in comparison to the cooling loads in the floors of building overlooking symmetric street. Basically, the cooling loads in studied building floors decreases with the increase of building (2) height due to the increasing of shading potential. For more details, building (2) height equals to $H_1 + 1$ floor (3.3m) can decrease the cooling loads in north-south oriented street axis in the summer by about 1.36%, 1.90%, 1.31%, 1.23%, 2.95% and 1.25% in the fifth floor, fourth floor, third floor, second floor, first floor and ground floor respectively. Building (2) height equals to $H_1 + 3$ floor can decrease cooling loads by about 15.08%, 11.75%, 9.44%, 6.65%, 7.89% and 8.79% in the successive floors. And building (2) height equals to $H_1 + 5$ floor can decrease the cooling loads by about 21.2%, 15.96%, 13.76%, 12.20%, 10.37% and 9.41% in various floors types. It is worthy of note that, there are some areas of the building (especially the roof) remains exposed for the major part of day in spite of the high buildings. This is attributable to the sun altitude of the study area where the sun's height reaches 82° in the summer, making the higher building only partly

effective in shading the studied building from the sun rays impinging laterally. In contrast, the heating loads in the studied building floors increases with the increase of building (2) height as a result of blocking the sun's rays by the higher building. For more clarity, building (2) height equals to H1+1floor can increase the heating loads in (N-S) oriented street axis in the winter period by about 0.90%, 0.82%, 1.20%, 1.03%, 1.17% and 0.35% in the fifth floor, fourth floor, third floor, second floor, first floor and ground floor respectively. Building (2) height equals to H1+3floor can increase heating loads by about 7.20%, 5.37%, 4.77%, 2.91%, 1.63% and 0.68% in various floors types. And building (2) height equals to H1+5floor can increase the heating loads by about 11.61%, 8.12%, 6.48%, 3.25%, 1.94% and 0.88% in the successive floors.

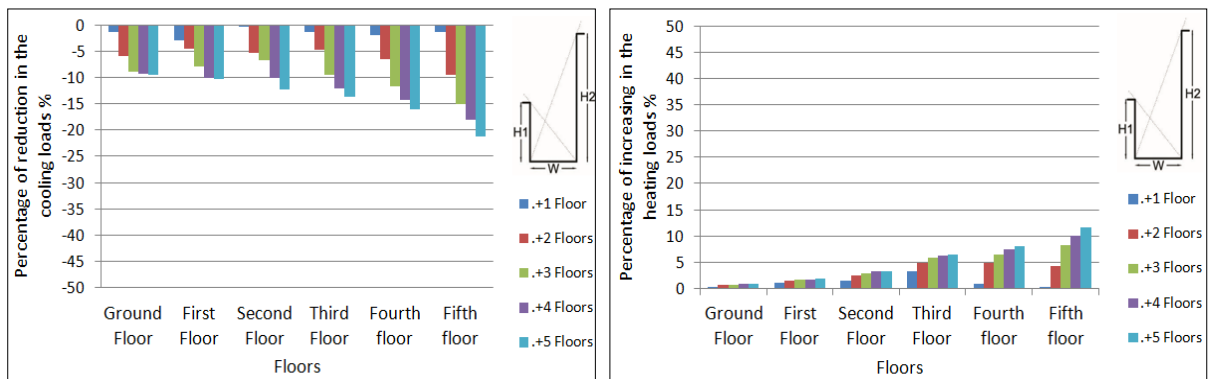

Figure (5.19): L: Percentage of reduction in the cooling loads in the building facing west in (N-S) street as a result of canyon asymmetry by IDA ICE, R: Percentage of in increasing the heating loads

From the total loads point of view, it can be observed from figure (5.20) that the total loads in the successive floors take the same trend of the cooling loads. However, an advantage for the (N-S) asymmetrical street is noted with a slightly better thermal situation in the upper floors when the sun's rays coming laterally from the east are blocked especially in the case of building (2) height equal to H1+5floor. On the whole, the asymmetry strategy has a good impact in reducing energy consumption in the floors of building facing west in (N-S) street in comparison to the energy consumption in the floors of building overlooking symmetric street.

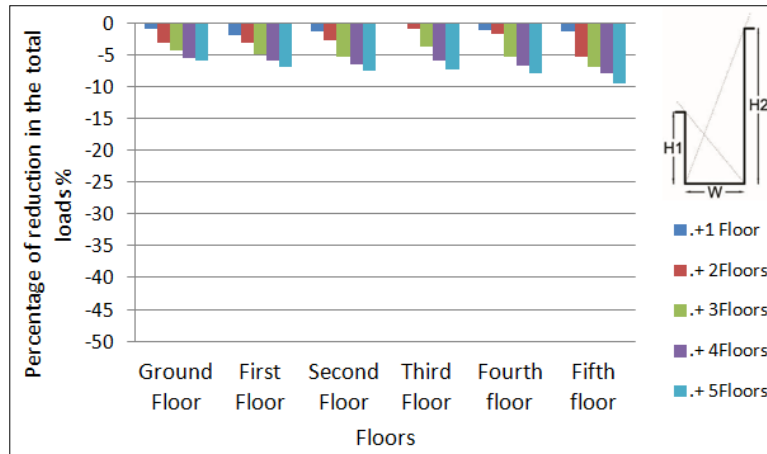

Figure (5.20): Percentage of reduction in the total loads in the building facing west in (N-S) street as a result of canyon asymmetry by IDA ICE

With regard to the impact of canyon asymmetry combined with orientation on energy consumption in studied building floors. Figure (5.21) shows that asymmetry in street design has an effective role in reducing the cooling loads in (E-W) street and thus offers a better thermal situation in comparison to asymmetry in (N-S) street. Changing the street orientation from the north- south to the east- west can decrease the cooling loads in the summer period by about 1.01%, 2.13%, 0.92%, 0.93%, 2.60% and 3.25% in the fifth floor, fourth floor, third floor, second floor, first floor and ground floor respectively in the case of building (2) height equals to H1+1floor. By about 20.84%, 12.13%, 12.44%, 11.54%, 8.99% and 9.71% in the successive floors in the case of building (2) height equals to H1+3floor. And by about 36.41%, 28.35%, 21.80%, 17.26%, 14.69% and 13.14% in the successive floors in the case of building (2) height equals to H1+5floor. It is noticed that the asymmetry in (E-W) street play the main role in mitigating the thermal stress in the upper floors. Hence, it is possible to minimize the high uncomfortable of the upper floors overlooking (E-W) street orientation by increasing the southern building height to get a large amount of shading on the studied building roof. Moreover, the heating loads in studied building floors increase with the increase of building (2) height, but the percentage of increasing in heating loads in (E-W) street is less than the percentage of increasing in (N-S) street. This comparison reveals that asymmetry strategy in (E-W) street is the most efficient because it can reduce undesirable radiation falling on the southern apartments overlooking in (E-W) street in the summer as well as promote solar access in the winter.

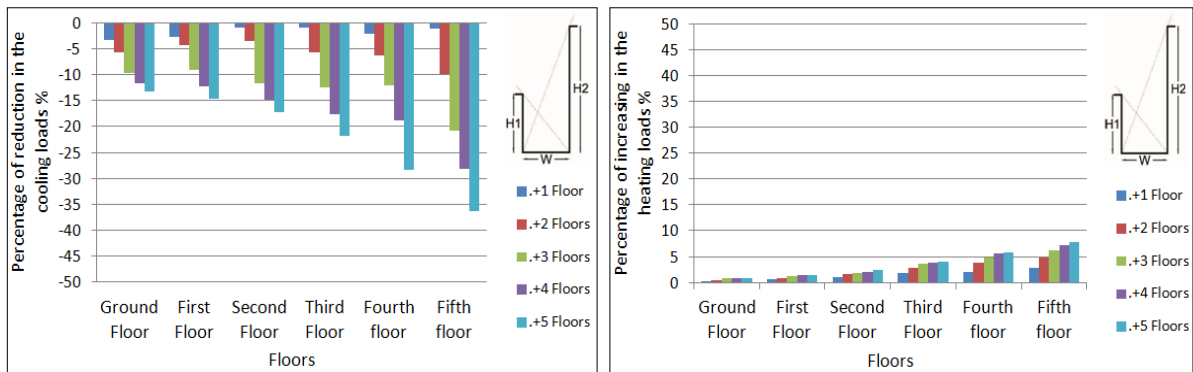

Figure (5.21): L: Percentage of reduction in the cooling loads in the building facing north in (E-W) street as a result of canyon asymmetry by IDA ICE, R: Percentage of increasing in the heating loads

5. Effects of the overhanging facades

The first case study is concerned with the impact of the width of overhanging facades which starts from the first floor on the cooling and heating loads in the three floors types. Figure (5.22) presents percentage of reduction in the cooling loads and percentage of increasing in the heating loads – street canyon without overhanging facades was taken as a reference case – in the three floors types in the building facing west in (N-S) street with aspect ratio $H/W = 4$ including overhanging facades with different width (w') and constant height (h'). The overhanging facades is 0.5m, 1.0m, 1.5m and 2.0m wide. The results indicate that the building with overhanging facades requires less cooling loads in comparison to the building without overhanging facades. For more clarity, overhanging facades width equal to 0.5m can decrease the cooling loads by about 0.05%, 0.96% and 4.47% in the upper floor, middle floor and ground floor respectively. Overhanging facades width equal to 1.0m can decrease the cooling loads by about 0.35%, 1.06% and 5.09% in various floors types. Overhanging facades width equal to 1.5m can decrease the cooling loads by about 0.62%, 1.35% and 5.89%. But overhanging facades width equal to 2.0m can decrease the cooling loads by about 0.85%, 1.91% and 7.15% in various floors types. It is worthy of note that, the percentage of reduction in the cooling loads in the ground floor is higher than the percentage of reduction in the middle and upper floor where the ground floor located directly under the overhanging facades which promotes more shade at the facades. In contrast, the heating loads in various floors types increase with the increase of overhanging facades width. It is noticed that the percentage of increasing in the heating

loads in the ground floor is higher than the others floors. Yet, no further effect on the upper floor is observed, which is equally uncomfortable.

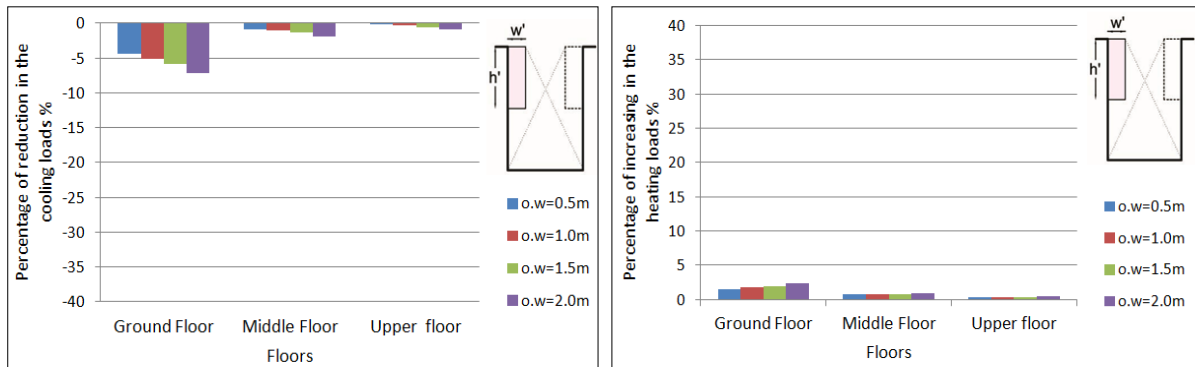

Figure (5.22): L: Percentage of reduction in the cooling loads in the building facing west in (N-S) street as a result of regular overhanging facades by IDA ICE, R: Percentage of in increasing the heating loads

On the whole, figure (5.23) shows, as expected, that in the case of the overhangs on the façades the thermal situation is less stressful than in a corresponding regular street (i.e. $H1 = H2$ and $H/W = 4$) where the total loads in the floors take the same reduction trend of the cooling loads. This figure suggests that the regular overhanging facades are moderately effective for the upper floors. By contrast, it seems to be noticeably more effective on the ground floor. Hence, it can possibly minimize the bad impact of the north-south streets by offsetting the façades in the upper floors to get a large shaded area.

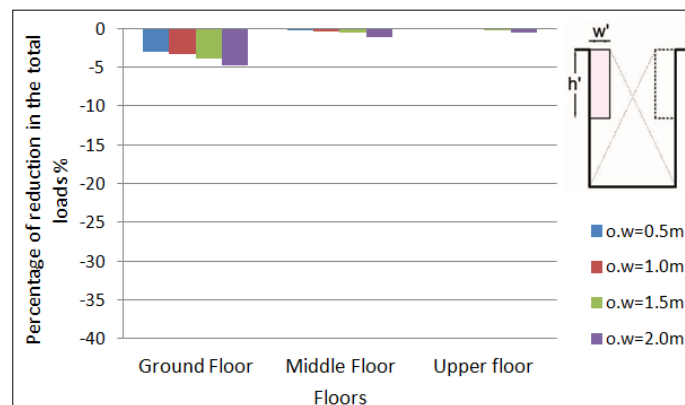

Figure (5.23): Percentage of reduction in the total loads in the building facing west in (N-S) street as a result of regular overhanging facades by IDA ICE

Moreover, figure (5.24) shows that the street orientation has a significant effect on reducing the cooling loads. For more details, changing the street orientation from the north- south to the east- west can decrease the cooling loads in the summer by about

0.34%, 1.60% and 5.01% in the upper floor, middle floor and ground floor respectively in the case of overhanging facades equal to 0.5m. By about 0.50%, 1.83% and 6.16% in the three floors types in the case of overhanging facades equal to 1.0m. By about 0.78%, 2.49% and 8.64% in the case of overhanging facades equal to 1.5m. And by about 1.10%, 3.17% and 9.79% in the three floors types in the case of overhanging facades equal to 2.0m. Ground floor shows an appreciable amelioration in the thermal comfort situation in summer. So overhanging facades design in the building facing north in (E-W) streets orientation is more effective in reducing the cooling loads, and thus reducing the energy consumption.

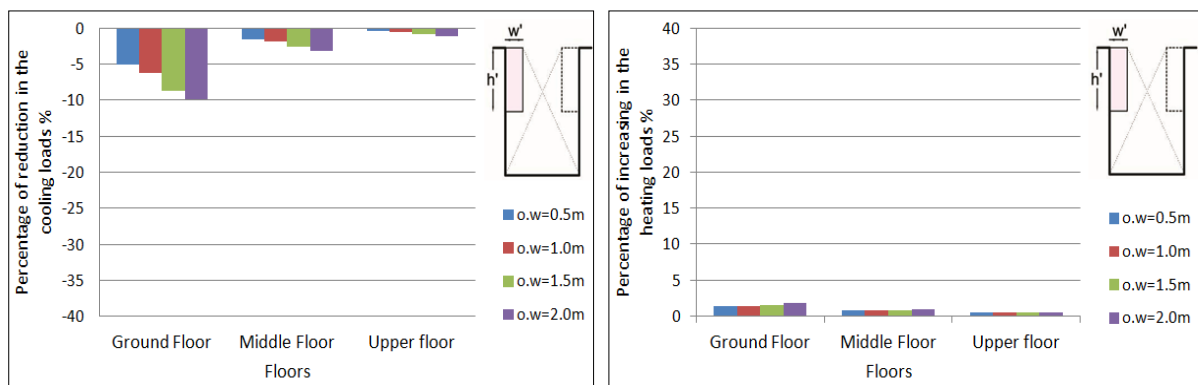

Figure (5.24): L: Percentage of reduction in the cooling loads in the building facing north in (E-W) street as a result of regular overhanging facades by IDA ICE, R: Percentage of increasing in the heating loads

The second case study is concerned with the impact of gradual overhanging facades (0.5m for each floor) on the cooling and heating loads in all floors of the building facing west in (N-S) street as well as the building facing north in (E-W) street. Figure (5.25) shows that the percentage of reduction in the cooling loads in (N-S) street in the summer increased with increasing the altitude of the floor taking into consideration that all floors (except the upper) located directly under the overhanging facades with width equal to 0.5 m. On the other hand, the effect of overhanging facades in the winter period is not remarkable. For more clarity, the gradual overhanging facades can decrease the cooling loads by about 2.47%, 7.24%, 12.14%, 10.95%, 7.54%, and 4.71% in the fifth floor, fourth floor, third floor, second floor, first floor and ground floor respectively. It is noticed that the gradual overhanging facades has an appreciable effect on reducing the cooling loads more than the effect of regular overhanging facades in the successive floors. This is due to

the effectiveness of gradual overhanging facades shading combined with adjacent building shading where the distance reduces between the opposite floors especially the upper.

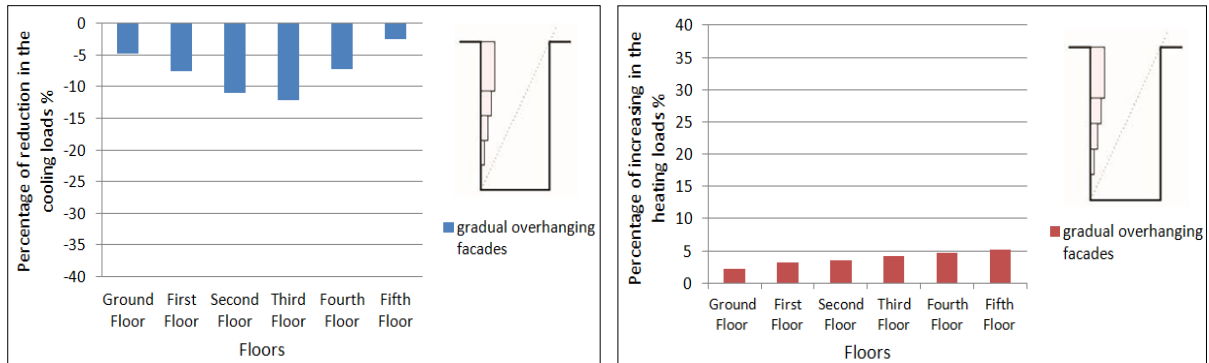

Figure (5.25): L: Percentage of reduction in the cooling loads in the building facing west in (N-S) street as a result of gradual overhanging facades, R: Percentage of increasing in the heating loads.

With regard to the impact of gradual overhanging facades along with orientation on energy consumption in the floors of the studied building. Figure (5.26) shows that gradual overhanging facades has an effective role in reducing the cooling loads in (E-W) street and thus offers a better thermal situation in comparison to (N-S) street. Changing the street orientation from the north- south to the east- west can decrease the cooling loads in the building with gradual overhanging facades by about 4.25%, 12.17%, 18.24%, 16.47%, 13.04% and 8.40% in the fifth floor, fourth floor, third floor, second floor, first floor and ground floor respectively. The graphics also shows that the percentage of increasing in heating loads in (E-W) street is less than the percentage of increasing in (N-S) street. This means that, more solar caption in winter is ensured together with a faster heat release in summer. This confirms the ability of the gradual overhanging facades in an (E-W) in mitigation the thermal stress efficiently especially in the southern apartments overlooking the street. So it is recommended to pay more attention to overhanging facades which can be in the form of balconies or inclined façades, etc.

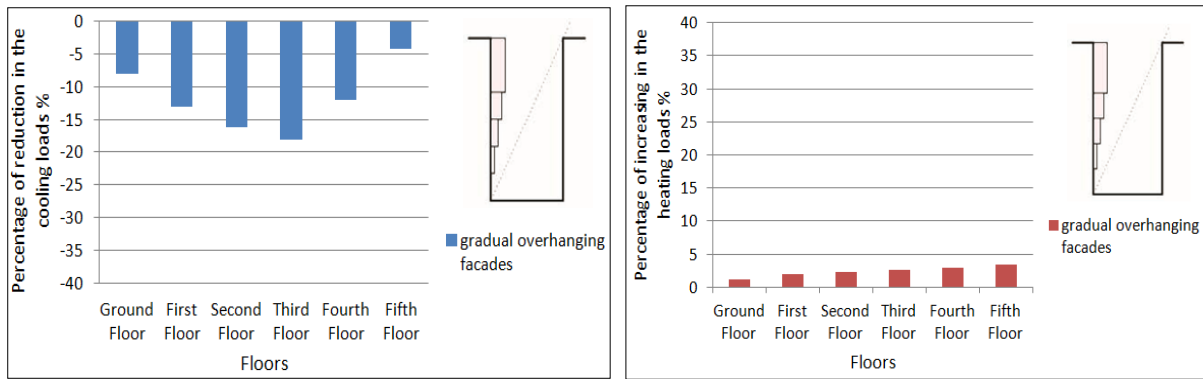

Figure (5.26): L: Percentage of reduction in the cooling loads in the building facing north in (E-W) street as a result of gradual overhanging facades by IDA ICE, R: Percentage of increasing in the heating loads

From the total loads point of view, it can be observed from figure (5.27) that the total loads in the successive floors take the same reduction trend of the cooling loads. In addition, it is noticed that in the case of the gradual overhanging facades the thermal situation is less stressful than in a corresponding regular street. Gradual overhanging facades show an appreciable amelioration in the thermal comfort situation during the year. On the whole, this strategy has a good impact on reducing energy consumption in the floors of building facing north in (E-W) street in comparison to the energy consumption in the floors of building overlooking symmetric street where offsetting the façades leads to a better protection especially of the southern apartments.

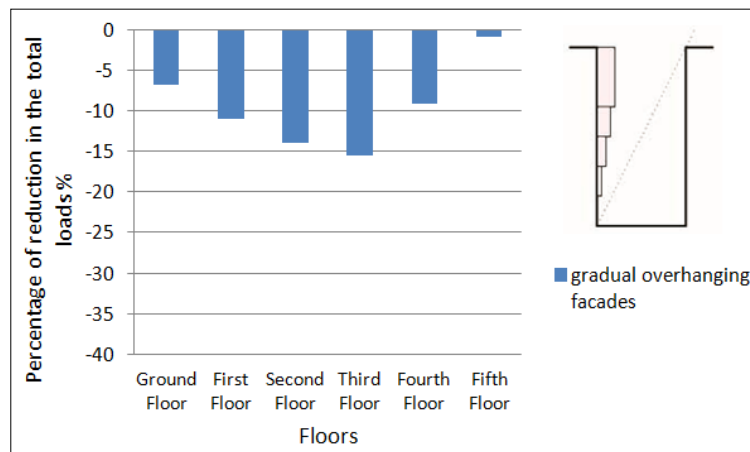

Figure (5.27): Percentage of reduction in the total loads in the building facing north in (E-W) street as a result of gradual overhanging facades by IDA ICE.

6. Geometric shape of the street

The study compares the thermal performance of the buildings overlooking the three main geometric shape of streets which are straight street, curved street and plover street. The study takes into consideration the north- south street orientation (to modify its thermal performance) and aspect ratio (H/W) equal to 2 which is considered as an average profile between shallow and deep profiles. The six buildings facing west are numbered to compare between each building with its counterpart which has the same number in the three geometric shapes of the street. Figure (5.28) shows that the buildings facing west in straight street has a bad behavior where it experiences the highest thermal discomfort and needs more total loads to achieve thermal comfort. This is attributable to the increase in solar radiation falling on façades of these buildings. On the other hand, the buildings facing west in plover street has a better behavior where it provides the highly thermal comfort situation and thus reduces the total loads. For more clarity, building no. (1) needs about 9.32 KWH/m³, 8.29 KWH/m³, 7.55 KWH/m³ to achieve thermal comfort in straight street, curved street and plover street respectively. Building no. (3) needs about 9.17 KWH/m³, 8.37 KWH/m³, 7.66 KWH/m³ to achieve thermal comfort in the three geometric shape of streets. And building no. (5) needs about 8.75 KWH/m³, 8.12 KWH/m³, 7.42 KWH/m³ in the three geometric shape of streets. So a plover street is desirable for reducing the total loads. Table (5.2) illustrates the three cases simulated in the study and the preferable buildings in each case.

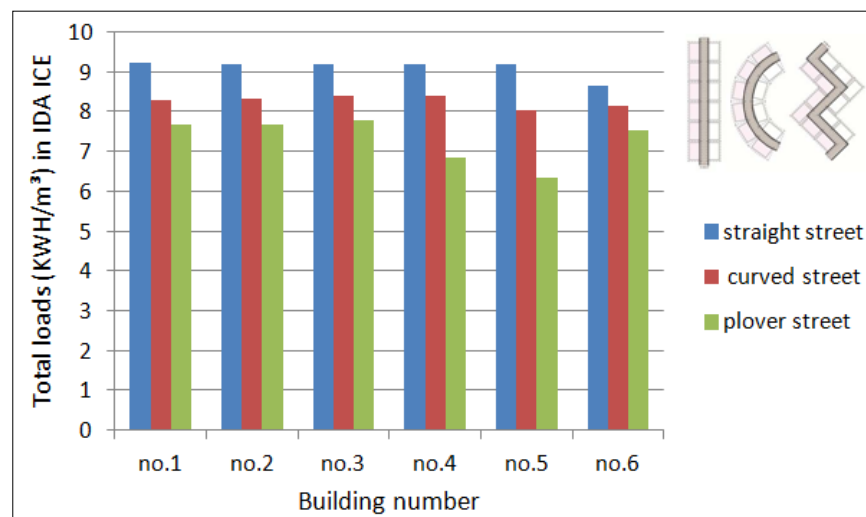
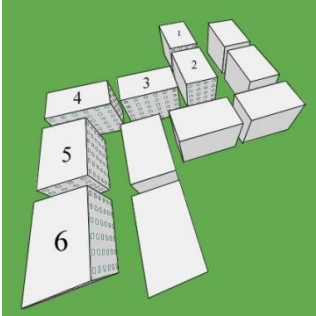
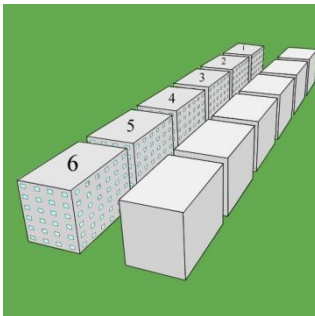
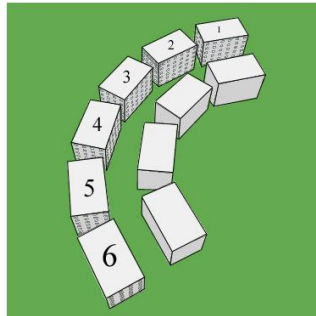

Figure (5.28): Percentage of reduction in the total loads in the building facing north in (E-W) street as a result of varying the geometric shape of the street.

Table (5.2): The three options investigated in the study

Total loads	Plover street (1,2,...6P)	Straight street(1,2...6S)	Curved street (1,2...6C)
Perspective			
Building no.			
1	Building (1P) is better than Building (1S) by about 20.5% in the total loads and better than Building (1C) by about 8.39%.	Building (1S) is worse than Building (1C) by about 11.19% in the total loads.	Building (1C) is better than Building (1S), but worse than Building (1P).
2	Building (2P) is better than Building (2S) by about 19.73% in the total loads and better than Building (2C) by about 8.61%.	Building (2S) is worse than Building (2C) by about 10.23% in the total loads.	Building (2C) is better than Building (2S), but worse than Building (2P).
3	Building (3P) is better than Building (3S) by about 17.96% in the total loads and better than Building (3C) by about 7.71%.	Building (3S) is worse than Building (3C) by about 9.51% in the total loads.	Building (3C) is better than Building (3S), but worse than Building (3P).
4	Building (4P) is better than Building (4S) by about 34.51% in the total loads and better than (4C) by about 23.11%. So Building (4P) achieves the best thermal behavior.	Building (4S) is worse than Building (4C) by about 9.26% in the total loads.	Building (4C) is better than Building (4S), but worse than Building (4P).
5	Building (5P) is better than Building (5S) by about 31.98% in the total loads and better than (5C) by about 22.80%.	Building (5S) is worse than Building (5C) by about 9.18% in the total loads.	Building (5C) is better than Building (5S), but worse than Building (5P).
6	Building (6P) is better than Building (6S) by about 15.10% in the total loads and better than (6C) by about 7.99%.	Building (6S) achieves the worst thermal behavior. It increases the total loads by about 7.11% and 15.10% more than Building (6C) and (6P) respectively.	Building (6C) is better than Building (6S), but worse than Building (6P).

5.3 Conclusion

This chapter is undertaken with the aim of studying the impact of street geometry on energy demand and finding out the optimum streets design. The methodology was mainly based on IDA ICE program. It mainly focused on the street properties included the aspect ratio H/W, street orientation and a number of architectural details, i.e. galleries, horizontal overhangs on façades, asymmetry and geometric shapes of the street. It is concluded that the relation between the street properties and the architectural details proportions of the building can affect the solar potential on the buildings surfaces and thus the thermal performance of the building.

It was concluded that the narrower canyons with aspect ratio (H/W) of 4.0 provides the most improvement in the thermal situation and decreases the total requirements throughout the year especially in the north- south street. In addition, the optimum galleries width in the ground floor for both east-west and north-south oriented street is 2.0m, where it offers a reduction in energy consumption per cubic meters by about 6.3% and 3.92 respectively. But the optimal galleries height depends on the covered floors directly. On the other hand, the asymmetrical profile ($H_2 > H_1$) revealed a better comfort conditions in the upper floors in E-W street, especially in the case of building (2) height equal to H_1+5 floor where it offers a reduction in energy consumption per cubic meters by about 44.98% due to blocking undesirable radiation. It is also concluded that the optimum overhanging facades width is 2.0m. But the gradual overhanging facades has an appreciable effect on reducing the energy consumption more than the effect of regular overhanging facades in the successive floors, where it offers a reduction in energy consumption per cubic meters by about 23.27% on the building level. Moreover, the study confirmed that the buildings facing west in (N-S) plover street has a better behavior where it provides the highest thermal comfort situation and thus reduces the energy demand.

Chapter 6: Conclusion and Recommendations

6.1 Introduction

The lack of the conventional energy combined with the environmental problems related to the increase in energy consumption made a great challenge for the world. In addition, climatic change and the global warming are another challenges which resulting from the increase in carbon dioxide emission. Buildings consume the bulk of the energy for thermal comfort requirements which makes buildings significantly contribute to increasing the environment problems. This thesis concentrated on important strategy which can be used in the Gaza Strip to reduce the demand of energy in buildings. It focused on the effect of street morphology on the solar radiation falling on facades as well as on the thermal performance of the building.

To achieve the purpose of research, the main factors which are street properties included the aspect ratio H/W and street orientation, a number of architectural details, i.e. galleries, horizontal overhangs on façades and asymmetry, vegetation and geometric shapes of the street are examined in the climatic condition of the Gaza strip, which is located in hot humid region on longitude $34^{\circ} 26'$ east and latitude $31^{\circ} 10'$ north. The study is structured into two parts. First part states a literature review about energy- efficient urban design, streets design, thermal performance of buildings and the situation in the Gaza strip. Second part is a parametrical study carried out using " IDA ICE" and "ECOTECT" programs to investigate the impact of previous factors on the overall energy consumption of a typical residential building model. This final chapter is dedicated to the summarization of the conclusions along with recommendations derived from the gathered data and the simulation which is discussed in this study.

6.2 Conclusions

The study can be classified into three major sections, including energy- efficient urban design, the situation in the Gaza strip and studying the impact of streets design on the overall energy demand. The following is a summary of the conclusions achieved by each of these sections:

6.2.1 Energy- efficient urban design

- Energy is essential to improve quality of life. However, using fossil conventional sources to produce energy causes several environmental effects including global warming and climate change.

- Energy efficiency and renewable energy are seen as an increasingly important alternative for reducing the pressures placed on the environment by energy production and consumption.
- Urban design affects both the solar and wind factors. It plays a significant role in determining the amount of solar radiation falling on the building's surface and the streets and determining the airflow around the buildings.
- There is an inverse relationship between residential population density and energy consumption. On the other hand, higher urban density has negative effects on the microclimate and the hydrology of the city.
- There is a positive relationship between diffuse radiation and sky view factor (SVF), the diffuse radiation decreases with decreasing sky view factor.
- The gradation in building heights helps wind movement which has a great impact on thermal comfort in urban areas. Decreasing buildings height towards the prevailing wind direction can enhance air movements.
- Rural areas which includes green spaces are cooler than built-up areas (cities) where trees can modify air temperature by preventing solar radiation and cooling the surrounded area by evapo-transpiration process.
- A building's envelope affects outdoor thermal comfort by its thermal mass, solar reflectance and transmittance.
- Energy efficiency urban design offers opportunities to improve the quality of urban life through design for a healthy and comfortable- built environment with minimum energy consumption.
- Factors affecting thermal comfort in urban street canyons are canyon geometry and orientation, use of galleries, canyon asymmetry, overhanging facades and use of vegetation.

6.2.2 The situation in the Gaza strip

- The Gaza strip needs (500) MW of electricity, while the available supply is (152) MW. The large part of this supply about (79%) is provided by Israeli Electricity Company but about (21%) is provided by Egyptian electric company. On the other hand, the Gaza Power plant does not provide anything (after the last war at 2014). Therefore, the Gaza Strip shortage of electricity is about 70%.
- The main problem of energy in the Gaza strip is that it has almost no conventional energy sources along with difficult procedures of Israel Electrical Company.
- In the Gaza strip, residential buildings are the largest consumer of energy that was exceeded 70% of the total energy consumed.
- The potential of using available renewable energy such as solar, wind and biomass energies in the Gaza strip may significantly decrease the energy reliance on neighboring countries.
- Streets and buildings in the Gaza strip take the orientation parallel and perpendicular to the coast (NE- SW) and (NW- SE) which do not take the climatic factors into consideration.
- Different planning models for streets appeared in the Gaza strip cities as a result of the difference of urban fabric from area to the other.
- The most important streets that penetrate the Gaza city can be classified into four types which are regional roads, the main streets, collector streets and local streets.
- Streets geometries have not been studied sufficiently in the Gaza strip except for some zones.

6.2.3 The impact of streets design on the overall energy demand

1. Aspect ratio and orientation

- Facades overlooking symmetrical shallowest canyon $H/W = 0.5$ is largely irradiated due to the intense solar irradiation especially in the summer. In contrast, the deepest canyon facades $H/W = 4$ receives the least amount of solar radiation.

The solar radiation are reduced by 130.2 % with increasing the aspect ratio (H/W) from 0.5 to 4.0 at (N-S) orientation.

- About 33.4% of reduction in the incident solar radiation falling on facades overlooking street with $H/W = 2.0$ occurs with changing the street orientation from the north- south to the east- west orientation.
- East- west oriented street axis is potentially good alternatives for combining the requirements of summer and winter in relation to solar energy (shading and solar radiation access).
- Buildings overlooking wide streets are highly uncomfortable during the year as they need more total requirement to achieve thermal comfort.
- Changing the street orientation from the north- south to the east- west orientation can decrease the cooling loads by about 37.25% and 22.08% per cubic meters for the building facing north perverted toward west at street with $H/W = 4.0$ and the building facing south perverted toward east respectively where the differences in the heating loads are not remarkable.
- The upper floors are highly uncomfortable for various aspect ratios. While the ground floor take the advantages of adjacent shading and also the U-value of the floor.
- The South- west apartment has a bad behavior for the various floors types. While the north- east apartment achieve a better thermal comfort where it offers a reduction in energy consumption per cubic meters by about 13.15% in the upper floor.
- Aspect ratio and orientation are the main factors for the thermal response in the buildings.
- Implementing shading strategies at buildings and streets level (galleries, overhanging façades, trees, etc.) are effective ways to improve effectively the comfort situation for shallow canyons.

2. Galleries, asymmetry and overhanging façades

- Using galleries revealed to be useful for reducing thermal stress. This is due to the effectiveness of their horizontal shading which reduced undesirable solar radiation.
- Increasing the galleries width of a (N-S) and (E-W) streets from 0.2W to 1.4W can decrease the incident solar radiation by 28.6% and 46.74% respectively in the summer. So the galleries of an (E-W) street are protected better than a (N-S) oriented street.
- Deeper and lower galleries are slightly irradiated due to the short duration of exposure to the sun.
- About 39.4% of reduction in the incident solar radiation falling on (E-W) street occurs with increasing the gallery width to street width ratio (w/W) from 0.2 to 1.4. And about 22.8% of reduction occurs with increasing the gallery height to building height ratio (h/H) from 0.2 to 0.9.
- The total loads are reduced by 5.20% in the ground floor with increasing the galleries width from 0.5m to 2.0m at the East- West orientation.
- Higher galleries effectively reduce the total requirement in the covered spaces especially the upper floors which are located directly under the gallery. About 15.7% of reduction in the total loads occurs in the fourth floor when the gallery height equal to 5 floors at (N-S) street. While 27.1% of the reduction occurs at (E-W) street.
- Discomfort can shortly extend under galleries especially for wide canyons and higher galleries.
- The asymmetrical canyon ($H_2/H_1 \neq 1$) revealed to be useful for reducing thermal stress, it protects efficiently from undesirable solar radiation in the summer at the same time ensured more solar access in winter.

- Increasing the buildings heights ratio H_2/H_1 of a (N-S) and (E-W) streets from 1.0 to 3.2 can decrease the incident solar radiation by 14.02% and 55.02% respectively in the summer.
- About 43.10% of reduction in the incident solar radiation falling on the area of (E-W) street occurs with increasing H_2/H_1 from 1.0 to 3.2 due to the effectiveness of shading.
- The reduction in the total loads is more remarkable in the asymmetrical canyon with increasing building 2 height H_2 from $H_1 + 1$ floor to $H_1 + 5$ floor.
- The asymmetry in (E-W) street play significant role in mitigation the thermal stress especially in the upper floors. Building (2) height equal to $H_1 + 5$ floor can decrease the total loads in the ground floor of building 1 by about 2.91%. While decrease the total loads in the upper floor by about 29.53%.
- The design of overhanging façades helps to increase the area of shade on facades and within the street.
- East-west oriented streets axis appear to be the best protected in comparison to N-S orientations. Increasing the overhanging width of a (N-S) and (E-W) streets from $0.1W$ to $0.45W$ can decrease the incident solar radiation by 40.64% and 50.49% respectively in the summer.
- Regular overhanging facades which starts from the first floor can reduce the total loads effectively on the ground floor.
- The gradual overhanging facades has an appreciable effect on reducing the total loads more than regular overhanging facades in the successive floors.
- strategies of galleries, asymmetry and overhanging façades have a good impact in reducing energy consumption especially in the southern apartments overlooking east-west street.

3. Geometric shapes of the street and trees

- Plover is the best geometric shape for the street where façades overlooking plover street receives the least amount of solar radiation in the summer.
- The buildings facing west in plover street has a better behavior where it provides the highest thermal comfort situation and reduces energy consumption while the buildings facing west in straight street has a bad behavior.
- About 19.82% of reduction in the total loads occurs in the building on plover street compared to the building on straight street.
- Increase the number of trees planted close to the façade more efficient in enhancing more shade and reducing undesirable radiation falling on façades and sidewalks in summer.
- Planting trees in east-west oriented streets axis is more affected than it in north-south orientation.
- Planting trees on centralized island is more affected on the area of streets than planting trees on southern or northern pavements where trees on centralized island cast its shadow fully on streets.

6.3 Recommendations

In light of the above findings, the following points are recommended:

- It is advisable to increase the awareness of architects and urban planners about the relevance of integrating strategies of energy efficient urban design during the different urban planning stages.
- Renewable energy sources available in the Gaza strip which are solar, wind and biomass energies, should be taken into consideration to solve the problem of energy.
- It is recommended to create integration and flexibility in planning and design for the purpose of energy saving and provide thermal comfort indoor and outdoor.

- Develop the residential building laws and legislations -which consumes the large part of the energy- in a way that promote energy efficiency. In addition, develop plans and strategies of streets design for reducing energy demand in building.
- It is recommended to increase the aspect ratio in order to increase the shaded areas on facades which helps to reduce the energy consumption as well as on the street which provides thermal comfort for pedestrians.
- It is advisable to avoid the bad effect of the north- south orientation by protecting the building facades which overlooks the street by different shading strategies such as galleries, asymmetry and overhanging façades in order to increase the shaded area on the street as well as on facades to enhance thermal response for buildings.
- It is recommended to direct the new main streets in the Gaza strip at the East-West axis.
- More attention must be paid to the gallery width to the street width ratio ranging from 0.6 to 1.0 to attract a large amount of solar radiation in the winter and less amount of radiation in the summer.
- It is recommended to draw attention on the relevance of the canyon asymmetry. It is advisable to use building heights ratio (H_2/H_1) ranges from 1.2 to 2.0 which is more preferable for both winter and summer needs.
- It is recommended to pay more attention to the design of overhanging façades where it works as horizontal shading devices (e.g. balconies) in order to increase the shading potential which positively affects the cooling loads.
- More attention must be paid to the upper floor -which experiences the highest thermal discomfort- by protecting the building roof from undesirable solar radiation in the summer by promoting planting and setting umbrellas.
- It is recommended to use the gradual overhanging facades which is better thermally than the regular overhanging facades especially in the wall facing south overlooking east- west oriented street axis.

- It is advisable to utilize the advantages of the different heights of buildings in achieving shading on the roof and building's façades.
- For the purpose of achieving thermal comfort in the summer, plover streets are more recommended to plan than north-south straight street which is highly uncomfortable.
- It is advisable to plant trees on the northern pavement for east-west oriented street axis which is more preferable for the northern sidewalks and walls facing south. While it is recommended to plant trees on the eastern and western pavements for north-south oriented street axis.
- It is recommended to take into account the number of trees and the appropriate distance between trees and facades to provide adequate shade on the street and facades and thus reduce the required energy.
- Several design possibilities based on encouraging shading which is the key strategy for promoting thermal comfort especially in the summer can be suggested:
 - ✓ A judicious combination of galleries and overhanging facades.
 - ✓ Greening the irradiated façades.

6.5 Suggestions for further studies

- This study discussed the effect of streets morphology on incident solar radiation and thermal performance. It is advisable to extend the work carried out in this study by investigating the impact of streets design on the performance of natural ventilation and lighting.
- It is recommended to pay more attention to field investigation for further validation.

References

A guide for designers, developers and owners (1998). *Natural ventilation in non-domestic buildings. Energy efficiency*. DETR environment transport regions. Good practice guide 237. London.

American Meteorological Society (2012). *Sunlight and Seasons, Project ATMOSPHERE develops and produces teacher's guides and other educational materials*.

Abu Hamed, T., Flamm, H. & Azraq, M. (2011). *Renewable Energy in the Palestinian Territories: Opportunities and Challenges*. Renewable and Sustainable Energy Reviews 1082–1088.

Abu-Hafeetha, M. (2009). *Planning for Solar Energy as an Energy Option for Palestine, master program*. An-Najah National University, Nablus, Palestine.

ADEME, (2004). *Energy Efficiency: A Worldwide Review Indicators, Policies, Evaluation*. London, United Kingdom.

Ahmed, A., & Mohammed, A. (2012). Using simulation for studying the influence of vertical shading devices on the thermal performance of residential buildings (Case study: New Assiut City). *Ain Shams Engineering Journal*, Egypt, 3, 163-174.

Albemarle County (Va.). Dept. of Planning and Community Development, (2000). *The Neighborhood Model: Building Block for the Development Areas*. Section 6, Torti Gallas and Partners-CHK.

Al-Qeeq, F. (2008). *Passive Solar Urban Design - Shadow Analysis of Different Urban Canyons*. Vol. 22, An - Najah Univ. J. Res. (N. Sc.). Palestine,.

Al-Tamimi, N., Fadzil, Sh., and Harun, W., (2011). The Effects of Orientation, Ventilation and Varied WWR on the Thermal Performance of Residential Rooms in the Tropics. *Journal of Sustainable Development*. 4 (2).

Applied Research Institute (ARIJ) (2003). *Climatic Zoning for Energy Efficient Buildings in the Palestinian Territories* (the West Bank and Gaza). Technical Report Submitted To United Nations Development Program/ Program of Assistance to the Palestinian People (UNDP / PAPP), Jerusalem, Palestine.

Autodesk Ecotect Analysis (2012). available at: <http://usa.autodesk.com/ecotect-analysis>.

Avissar, R. (1996). Potential effects of vegetation on urban thermal environment. *Atmospheric Environment*. 30, 437-448.

Aye, L., Charters, W., Fandiño, A., & Robinson, J. (2005). *Thermal Performance of Sustainable Energy Features*. Australia.

Azri, N., Zurigat, Y., & Al-Rawahi, N. (2012). Development of Bioclimatic Chart for Passive Building Design in Muscat-Oman. European Association for the Development of

Renewable Energies, Environment and Power Quality (EA4EPQ). *International Conference on Renewable Energies and Power Quality (ICREPO)*. Santiago de Compostela (Spain).

Baker, N. (1987). *Passive and low energy building design for tropical island climates, Martin Centre*. Prepared for the Commonwealth Science Council by The ECD Partnership, University of Cambridge, London, U.K.

Baker, P., (2011). *U- values and traditional buildings: In situ measurements and their comparisons to calculated values*. Conservation Group, Historic Scotland Technical, p10.

Bar L., Ioannis, X. & Hoffman T. (2012). Passive cooling design options to ameliorate thermal comfort in urban streets of a Mediterranean climate (Athens) under hot summer conditions. *Building and environment* (57), 110-119.

Bar, L. & Hoffman, M. (2000). Vegetation as a climatic component in the design of an urban street An empirical model for predicting the cooling effect of urban green areas with trees. *Energy and Buildings* 31, 221–235.

Bar, L. & Hoffman, M. (2003). Geometry and orientation aspects in passive cooling of canyon streets with trees. *Energy and Buildings* 35, 61–68.

Bashitialshaaer, R. (2011). *Analysis and Modelling of Desalination Brines. Water resources engineering*. Doctoral dissertation. LUND Sweden.

Bearden, T. (2000). *The Unnecessary Energy Crisis: How to Solve It Quickly, Association of Distinguished American Scientists (ADAS) Position Paper: Solution to the Energy Crisis*. U.S.A.

Bilen, K. (2008). Energy production, consumption, and environmental pollution for sustainable development: A case study in Turkey. *Renewable and Sustainable Energy Reviews Journal* 12, 1529–1561.

Brown, R. & Gillespie, T. (1995). *Microclimate Landscape Design: Creating Thermal Comfort and Energy Efficiency*. John Wiley & Sons, New York.

Bruce, D. & Hartman, J. (1996). *Sustainable urban transportation initiatives in Canada*. Paper submitted to the APEC Forum on Urban Transportation, Seoul, South Korea.

Burgos, M., Wanck, S., Schmidt, J., Hastings, H. & Gorham, E. (2008). *Solar Cooker Earth Analog and Comparison of Design efficacy*. Global Climate Change.

Çakir, Ç. (2006). *Assessing Thermal Comfort Conditions; A Case Study on The Metu Faculty of Architecture Building* (Master Thesis). The Graduate School of Natural and Applied Sciences. The Middle East Technical University, Turkey.

Chan, A., So, E. & Samad, S. (2001). Strategic guidelines for street canyon geometry to achieve sustainable street air quality. *Atmospheric Environment*. 35, 4089–4098.

Clearwater (2012). *Raingarden design principles*. quick reference guide.

Coronel, J. & Alvarez S. (2001). Experimental work and analysis of confined urban spaces. *Solar Energy* 70, 263-273.

CSR Hebel Technical Manual (2006). Version 1.

CUHK, (2012). *Urban Climatic Map and Standards for Wind Environment - Feasibility Study. Executive Summary*. Towards quality urban living, for now and for the future. School of Architecture.

Cuthbert, A. (2006). *The form of Cities, Carlton*. Victoria: John Wiley.

Daley, M. (2007). *Street and site plan design standards, City of Chicago*. Chicago Department of Transportation Street and Site Plan Design Standards.

Datta, G. (2001). Effect of fixed horizontal louver shading devices on thermal performance of building by TRNSYS simulation. *Renew. Energy* 23, 497–507.

DeKay, M. (2003). *Climatic urban design configuring the urban fabric to support day lighting passive cooling and solar heating*. USA.

Department for Transport (2007). *Manual for Streets. Communities and local government*. Britain.

Department of Energy and Climate Change (2012). *The Energy Efficiency Strategy: The Energy Efficiency Opportunity in the UK*. London.

DETR environment transport regions, (2000). *Urban design in the planning system: towards better practice*. Commission for Architecture and the Built Environment. Britain.

DETR (2000). *Urban design in the planning system: towards better practice*. Eland House Bressenden Place London SW1E 5DU, p8.

Droege, P. (2009). *Project S4G-solar for Gaza, institute of architecture and planning*. Hochschule Liechtenstein, Germany.

Dubois, M. (2000). *Simple chart to design shading devices considering the window solar angle dependent properties*. Proceedings of the Third ISES Europe Solar Congress: Eurosun, Copenhagen (Denmark).

Duverne, S. & Baker, P. (2013). *Research into the thermal performance of traditional brick walls*. English heritage research report.

ECREEE, (2012). *The ECOWAS Energy Efficiency Policy (EEEP)*. ECOWAS Regional Centre for Renewable Energy and Energy Efficiency (ECREEE). ECOWAS Energy Efficiency Policy.

EDA collaborative Inc. (2010). *Carrville District Centre Urban Design- Streetscape Master Plan Study. the city of Vaughan*.

El-deeb, K., El-zafarany, A. & Sherif, A. (2012). Effect of Building Form and Urban Pattern: On Energy Consumption of Residential Buildings in Different Desert Climates. *28th Conference, Opportunities, Limits & Needs Towards an environmentally responsible architecture Lima.*

ElHissi, Sh. (2012), *Studying the Microclimatic Effects of Trees on Thermal Performance of Residential Buildings in the Gaza Strip* (master thesis), architecture program, Islamic University, Gaza.

ENERGIE (2000). *Sustainable Urban Design. Produced by Energy Research Group.* University College Dublin, School of Architecture, Richview, Clonskeagh, Dublin 14, Ireland with the support of the European commission Directorate-General Energy & Transport.

Eppell, V., McClurg, B. & Bunker, J. (2001). A four level road hierarchy for network planning and management. In Jaeger, Vicki, Eds. *Proceedings 20th ARRB Conference*, Melbourne.

EQUA Simulation AB (2013a). *Getting Started with IDA Indoor Climate and Energy - Version 4.5.*

EQUA Simulation AB (2013b). *User Manual - IDA Indoor Climate and Energy- Version 4.5.*

European Communities (2006). *European energy and transport: Scenarios on energy efficiency and renewable.* Directorate-General for Energy and Transport. Belgium.

EVANS, R. (2005). Urban morphology. 16 (93).

Fadzil, Sh., & Sia, Sh. (2004). Sunlight control and daylight distribution analysis: the KOMTAR case study. *Building and Environment*, 39, 713 – 717.

Faggianelli, G., Brun, A., Wurtz., E., & Muselli., M. (2014). Natural cross ventilation in buildings on Mediterranean coastal zones. *Energy and Buildings* 77, 206–218. Available online at www.sciencedirect.com.

Federer C.A. (1976). Trees modify the urban microclimate, *journal of arboriculture*. 2 (7), 121-127.

Forbes, G. (n.d.). *Urban Roadway Classification- Before the Design Begins*. Canada.

Forsyth, A. (2003). *Measuring Density: Working Definitions for Residential Density and building Intensity*. Design Centre for American Urban Landscape, University of Minnesota.

Frank, C. & Bertolini, L. (2003). Achieving sustainable accessibility: An evaluation of policy measures in the Amsterdam area. *Built Environment*, 29 (1), 36-47.

Gabriel, A. & Vasile, N. (2011). *The use of electromagnetic field in heating a room*. Scientific Bulletin of the Electrical Engineering Faculty.

Ghazizadeh, S., Neda, M. & Mahmoodi, A. (2010). The impact of the architectural design on the thermal comfort of the outdoor spaces in residential complexes. *Honar-ha-ye-Ziba*, (42) 59–70.

Ghisi, E. & Massignani, R. (2007). Thermal performance of bedrooms in a multi-storey residential building in southern Brazil, *Building and Environment*, 42, 730–742.

Givoni, B., Noguchi, M., Saaroni, H., Pochter, O., Yaacov, Y. & Becker, S. (2003). Outdoor comfort research Issue. *Journal of Energy and Buildings*, 35, 77–86.

Goulding, J., Lewis, O. & Steemers, T. (1992). *Energy in Architecture: The European Passive Solar Handbook*. B.T. Batsford for the Commission of the European Communities, Directorate General XII for Science, Research and Development, London.

Government of Ireland (2010). *Energy efficiency in traditional buildings*. Ireland, The stationery office.

GSAP (Gresham smith and partners) (2009). *Complete Streets Design Guidelines. Report was funded in part through grant(s) from the Federal Highway Administration and Federal Transit Administration*. U.S. Department of Transportation and the Tennessee Department of Transportation.

Hamed, T., Flamm, H. & Ismail, L. (2012). *Assessing renewable energy potential in palestine*. world renewable energy forum empowering the world with renewable energy. Arava institute.

Hämmerle, M., Gál, T., Unger, J. & Matzarakis, A. (2011). *Introducing a script for calculating the sky view factor used for urban climate investigations*. ACTA climatologica et chorologica universitatis szegediensis, tomus, 44-45, 83-92.

Höppe, P. (2002). Different aspects of assessing indoor and outdoor thermal comfort. *Journal of Energy and Buildings*.34, 661-665.

HORIZON, (2009). *Urban Design Handbook*. City of Baton Rouge - Parish of East Baton Rouge - Planning Commission.

Housing Development & Management (2009). *Climate Conscious Architecture and Urban Design in Jordan: Towards energy efficient buildings and improved urban microclimate*. Swedish International Development Cooperation Agency (Sida).

Ibrik, E. (2009). *Energy Profile and the Potential of Renewable Energy Sources in Palestine*. In Renewable Energy in the Middle East, ed. M. Mason and A. Mor, 71-89. Dordrecht: Springer.

IEA (International Energy Agency) (2010). *Energy technology perspectives, Scenarios & Strategies to 2050*. France.

Index mundi, (2014). *Gaza Strip Demographics Profile, CIA world Factbook*.

INFRA, (2011). *Creating places for people an urban design protocol for Australian cities*, p5.

INFRA (2011). *Creating places for people an urban design protocol for Australian cities*. Australia.

Introduction to Thermodynamics (2008). *Introduction to Thermodynamics and Heat Transfer* (2nd ed). Heat Transfer. The McGraw–Hill Companies.

IPCC (2001). *Climate Change 2001: Synthesis Report, Third Assessment Report Intergovernmental Panel on Climate Change*. Cambridge.

ISO 7730 (1994). *Moderate thermal environments – Determination of the PMV and PPD indices and specification of the conditions for thermal comfort*. (2nd ed), International Organisation for Standardisation.

Jabareen, Y. (2006). Sustainable Urban Forms: Their Typologies, Models, and Concepts. *Journal of Planning Education and Research*. 26,38-52.

Johansson, E. (2006). Influence of urban geometry on outdoor thermal comfort in a hot dry climate: A study in Fez, Morocco. *Journal of Building and Environment*, 41(10), 1326-1338.

Johnson, B.M. (1981). *Patterns of residential occupancy*. National research council of Canada division of building research.

Karasu, A. (2010). *Concepts for Energy Savings in the Housing Sector of Bodrum, Turkey: Computer based analysis and development of future settlements using renewable energy* (PhD Thesis). Technique University Berlin, Germany.

Khalil, H. (2014). *Energy Efficiency Strategies in Urban Planning of Cites*. Cairo University, Egypt.

Khan, A. (2008). FAR as a Development Control Tool: A New Growth. *Jahangirnagar Planning Review*, 6, 4956.

Kim, G., Lom., H., Lim, T., Schaefer, L. & Kim, J. (2012). Comparative advantage of an exterior shading device in thermal performance for residential buildings. *Journal of Energy and Buildings*. 46, 105-111.

klemm, K. (2007). *Application of numerical simulation in assessment of microclimatic condition in urban areas*. Institute of Architecture and Urban Planning, Technical University of Lodz, Lodz, Poland. Proceedings: Building Simulation.

Kontoleon, K. (2012). Dynamic thermal circuit modelling with distribution of internal solar radiation on varying facade orientations. *Journal of Energy and Buildings* 47, 139–150.

Kottek, M., Grieser, J., Beck, Ch., Rudolf, B. & Rubel, F. (2006). World Maps of Köppen-Geiger climate classification updated, *Meteorologische Zeitschrift*, 15 (3), 259-263.

Krüger, E., Pearlmutter, D., & Rasia, F. (2010). Evaluating the impact of canyon geometry and orientation on cooling loads in a high-mass building in a hot dry environment. *Applied energy*, (87), 2068-2078.

Lam, J. & Li, D. (1999). An analysis of daylighting and solar heat for cooling-dominated office buildings. *Journal of Solar Energy*, 65 (4), 251-262.

Laouadi A. & Parekh A. (2007). Complex fenestration systems: towards product ratings for indoor environment quality. *Lighting Research and Technology*, 39(2), 109-122.

Littlefair, P. (1998). *Passive solar urban design: ensuring the penetration of solar energy into the city*. Renewable and Sustainable Energy Reviews. Building Research Establishment, Garston, Watford, U.K.

Mahlia, T., Taufiq, B., Ismail & Masjuki, H. (2007). Correlation between thermal conductivity and the thickness of selected insulation materials for building wall, *Journal of Energy and Buildings*, 39, 182–187.

Mahmoud, M. & Ibrik, I. (2003). Field Experience on Solar Electric Power Systems and Their Potential in Palestine. *Renewable and Sustainable Energy Reviews*, 7 (6), 531-543.

Majumda, M. (2002). *Energy-efficient building in India*. Published by Tata Energy Research Institute, Darbari Seth Block, India.

Marsh, Andrew (2003). Ecotect and Energy Plus. *The Building Energy Simulation User News*, 24 (6).

Martinez, I. (2014) . *Human thermal comfort*.

McPherson, E., Nowak, D. & Rowntree, R. (1994). *Chicago's urban forest ecosystem: Results of the Chicago urban forest climate project*. USDA forest service. General Technical report NE-186.

MED-ENEC (2013). *Energy Efficient Urban Planning*. Energy Efficiency in the Construction Sector in the Mediterranean Guidelines. This project is funded by the European Union.

Mikler, V., Bicol, A., Breisnes. B. & Labrie, M. (2009). *City of Vancouver - Passive Design Toolkit*. British.

Ministry of Local Government (2004). *The Palestinian Guidelines for Energy Efficient Building Design*.

Ministry of Local Government (2004). *The Palestinian Code of Energy Efficient Buildings*. Ramallah, Palestine.

Ministry of Local Government. Structural plan system for the Gaza city for 1997. Gaza, the Palestinian National Authority.

Monam, A. & Rückert, K. (2013). *The Dependence of Outdoor Thermal Comfort on Urban Layouts*. Developing Energy-Efficient Urban Fabric in the Tehran-Karaj Region. the Technische Universität Berlin.

Muhaisen, A. (2007). *The energy problem in Gaza Strip and its potential solution, Energy and environment protection in sustainable development conference ICEEP*. Palestine polytechnic university, Hebron, Palestine.

Musalam, A. (2013). Water as a Possible Energy Resource to the Shortages in Electrical Power Supply: the Gaza Strip Case. *International journal of renewable energy research* 3, 1.

Nayak, J. & Prajapati, J. (2006). *Handbook on energy conscious buildings*. Indian institute of technology, Bombay and Solar energy center Ministry of non-conventional energy sources, Government of India.

Open street map, 2012, available at: <http://www.openstreetmap.org/>, accessed in: 13 October 2014.

Oral, G. & Yilmaz, Z. (2003). Building form for cold climatic zones related to building envelope from heating energy conservation point of view. *Journal of Energy and Buildings*, 35, 383–388.

Otak, Inc. (2007). *Streetscape Urban Design Elements*. City of Cheyenne. Carbondale.

Palestinian Central Bureau of Statistics (PCBS), (2007). *Palestinian central bureau of statistics, housing projections up to 2017*. Ramallah: PCBS.

Papadopoulos, A. (2001). The influence of street canyons on the cooling loads of buildings and the performance of air conditioning system. *Journal of Energy and buildings*, 33, 601-607.

Pearlmutter, D., Bitan, A., & Berliner, P. (1999). Microclimatic analysis of “compact” urban canyons in an arid zone. *Atmospheric Environment*, 33, 4143-4150.

PENRA (Palestinian Energy and Natural Resources Authority), 11-09-2014, interview with Eng. Saeb El Shawa.

Pereira, F., Silva, C. & Turkienikz, B. (2001). A methodology for sunlight urban planning. A computer-based solar and sky vault obstruction analysis. *Journal of Solar Energy* 70, 217-226.

Pisello, A., Bobker, M., & Cotana, F. (2012). A Building Energy Efficiency Optimization Method by Evaluating the Effective Thermal Zones Occupancy. *Energies Journal*, 5, 5257-5278.

Planning and Environment Services (2004). *Residential Design Guide*. Supplementary Planning Guidance Note 1. Bromsgrove District Council.

Rehan, R. (2013). Sustainable streetscape as an effective tool in sustainable urban design, Housing and Building National Research Center, *HBRC Journal*, 9, 173–186.

Ritter, M. (2009). *The Physical Environment: an Introduction to Physical Geography, available*.

Roos, C. (2008). *Principles of Heat Transfer, Energy Efficiency Factsheet*. Washington, USA.

Rosenlund, H. (2000). Climatic Design of Buildings using Passive Techniques. *Building Issues*, 10 (1), 3-26.

Ryan, L. & Campbell, N. (2012). *Spreading the net: the multiple benefits of energy efficiency improvements*. International Energy Agency.

Sam C. (2001). Low energy building design in high density urban cities. *Renewable Energy*, 24, 627-640.

Santamouris, M., Papanikolaou N., Koronakis I., Livada I. & Asimakopoulos, D. (1999). Thermal and air flow characteristics in a deep pedestrian canyon under hot weather conditions. *Atmospheric Environment*, 33, 4503-4521.

Santin, O., Itard, L. & Visscher, H. (2009). The effect of occupancy and building characteristics on energy use for space and water heating in Dutch residential stock. *Journal of Energy and Buildings* 41, 1223–1232.

Sen, Z. (2008). *Solar Energy Fundamentals and Modeling Techniques: Atmosphere, Environment, Climate Change and Renewable Energy*. Istanbul Technical University Faculty of Aeronautics and Astronautics, Dept. Meteorology, Campus Ayazaga, Istanbul, Turkey.

Seppanen, O. (2008). Ventilation Strategies for Good Indoor Air Quality and Energy Efficiency. *International Journal of Ventilation*, 6 (4), 297-306.

Shahidan, M., Shariff, M., Jones, P., Salleh, E. & Abdullah, A. (2010). A comparison of Mesua ferrea L. and Hura crepitans L. for shade creation and radiation modification in improving thermal comfort, *Landscape and Urban Planning*, 97, 168–181.

Skinner, C. (2006). Urban Density, Meteorology and Rooftops. *Urban Policy and Research*, 24 (3), 355-367.

Sofia, J. (1995). *Fundamentals of Thermal Resistance Measurement*. Analysis Tech.

Solupe, M. & Krarti, M. (2014). Assessment of infiltration heat recovery and its impact on energy consumption for residential buildings. *Energy Conversion and Management*, 78, 316–323.

Stemers, K. (2003). Energy and the city: density, buildings and transport. *Energy and Buildings*, 35, 3–14.

Streetscape guidelines (2003). *Streetscape Guidelines*. City of Stamford.

Stromann-Andersen, J., & Sattrup, P. (2011). The urban canyon and building energy use: Urban density versus daylight and passive solar gains, *Energy and Buildings*, 8 (43), 2011-2020.

Swaid, H., Bar-El, M. & Hoffman, M. (1993). A bioclimatic design methodology for urban outdoor spaces. *Theor. Appl. Climatol*, 48, 49-61.

Swinney, J. (2010). *A policy statement for Scotland designing streets*. The Scottish Government.

Szokolay, S. (2004). *Introduction to architecture science: the basis of sustainable design*. Published by Architectural Press, An imprint of Elsevier Science.

Taleghani, M., Kleerekoper, L., Tenpierik, M. & Dobbelsteen, A. (2014). Outdoor thermal comfort within five different urban forms in the Netherlands. *Building and Environment*, 1-14.

TGM (Transportation and Growth Management), (2003). *Street Design Basics. Connecting Transportation & Land Use Planning*. This TGM project is financed, in part, by federal Transportation Equity Act for the 21st Century (TEA-21), and the State of Oregon funds.

The Ministry of Planning and International Cooperation (1998). **Regional plan for the Gaza provinces, the first part**. Gaza Municipality, the Palestinian National Authority.

Torcellini, P. (2001). *Passive Solar Design for the Home*. Energy efficiency and renewable Energy. NREL.

Toudert, A. (2005). *Dependence of Outdoor Thermal Comfort on Street Design in Hot and Dry Climate*. Freiburg.

Toudert, F. & Mayer, H. (2007). Effects of asymmetry, galleries, overhanging facades and vegetation on thermal comfort in urban street canyons. *Journal of Solar Energy*, 81, 742–754.

Unal, H. & Alibas, K. (2007). Agricultural Residues as Biomass Energy, *Energ. Source*. Part B. 2, 123-140.

UNEP (2009). *Buildings and Climate Change: Summary for Decision-Makers*. Sustainable Buildings & Climate Initiative.

United Nation (2012). *The Humanitarian Impact of Gaza's Electricity and Fuel Crises*. United Nations Office for the Coordination of Humanitarian Affairs occupied Palestinian territory.

U.S. Environmental Protection Agency, (2011). Energy Efficiency in Local Government Operations, A Guide to Developing and Implementing Greenhouse Gas Reduction Programs.

Utzinger, M. & Wasley, J. (1997). *Building Balance Point, the University of California*. Berkeley.

Valsalakumari, P., Rajeevan, P., Sudhadevi, P. & Geetha C. (2008). *Flowering trees, new India publishing agency*. New Delhi, India.

Vardoulakis, S., Fisherb, B., Pericleousa, K. & Flesca, N. (2003). Modelling air quality in street canyons: a review. *Atmospheric Environment*, 37 (2), 155-182.

Yamartino, R. & Wiegand G. (1986). Development and evaluation of simple models for the flow, turbulence and pollution concentration fields within an urban street canyon. *Atmospheric Environment*, 20, 2137-2156.

Yaseen, B. (2012). *Renewable Energy Applications in Palestine*. Palestinian Energy and Environment Research Center (PEC).

Yu, J., Xu, X. & Tian, L. (2011). Effect of Envelope Design on Energy Consumption Respect to EETP Index. *International Conference on Computer Distributed Control and Intelligent Environmental Monitoring (CDCIEM)*.

Zotefoams plc (2007). *Technical information Sheet- TIS 10*. thermal conductivity of Azote Foams.

Internet Websites

Ahumphreys (2010), Defining "Street," "Road," "Avenue," "Boulevard". Retrieved January 18, 2015 from <http://www.usingenglish.com/forum/threads/137875-Defining-quot-Street-quot-quot-Road-quot-quot-Avenue-quot-quot-Boulevard-quot>

المراجع العربية
الكحلوت، محمد (بدون) " حالة الطرق المرورية في قطاع غزة – مشاكل وتوصيات.

APPENDIX1

Table (1): Default settings for ECOTECT and IDA ICE

	ECOTECT	IDA ICE
Location and Site Data		
Location		
Weather File Data	ISR_ Tel. Aviv-Bet Dagan	ISR_ Tel. Aviv-Bet Dagan
Latitude	32.0 N	32.0 N
Longitude	34.8 E	34.8 E
Altitude (m)	20	20
Site Data		
Ground reflectance	0.2	
Terrain types	Urban	Urban
Wind exposure	Normal	Normal
Thermal Condition		
HVAC System	Full Air Conditioning	Fans according to their schedules
Thermostat Range	18.0°C- 26.0°C	18.0°C- 26.0°C
Heating set point	18.0°C	18.0°C
Cooling set point	26.0°C	26.0°C
Use of the building/ Hours of Operation	On continuously	On continuously
Design condition		
Clothing (clo)	1.0	
Humidity	60.0	
Air speed	0.5 m/s	0.5 m/s
Lighting level	300 lux	300 lux
Occupancy	0	0
Internal heat gain		
Sensible gain	0	0
Latent gain	0	0
Infiltration rate		
Air change rate	0	0
Wind Sensitivity	0	0
Construction		
Exterior walls		
U-value	2.25	2.24
Roof		
U-value	2.35	2.35
Ground-contact/exposed		
U-value	0.88	0.8138
Window		
U-value	6.0	5.8

ECOTECT Setting

The main window of the program.

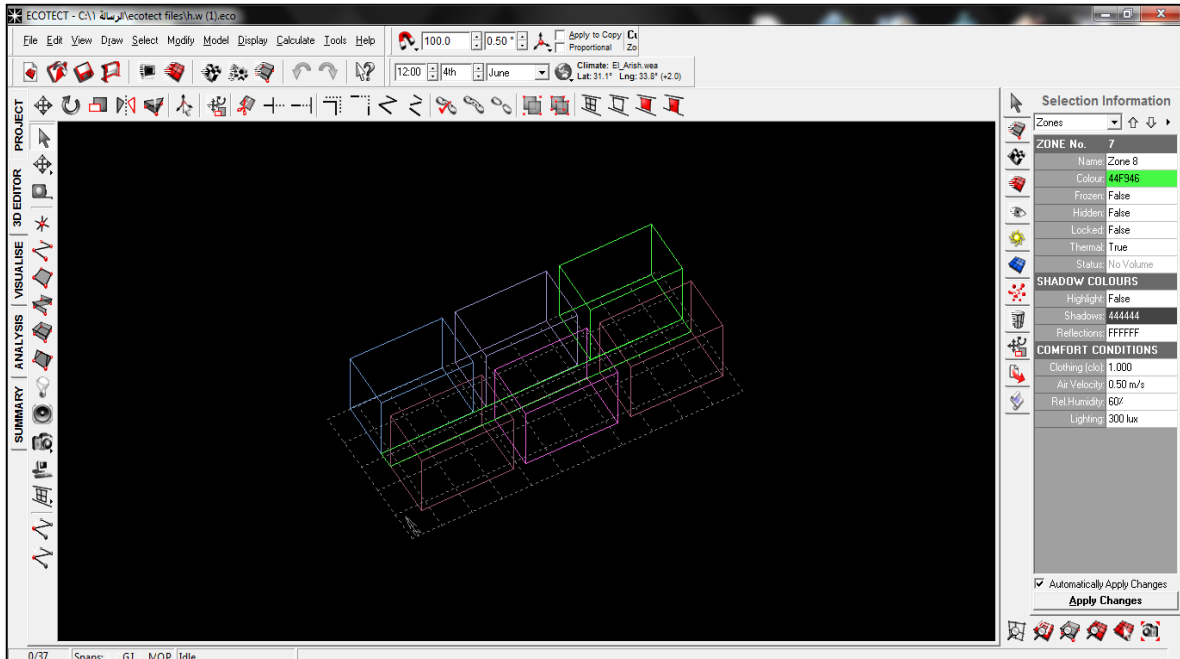

Figure (1): The main window of ECOTECT

Location and Site Data in ECOTECT

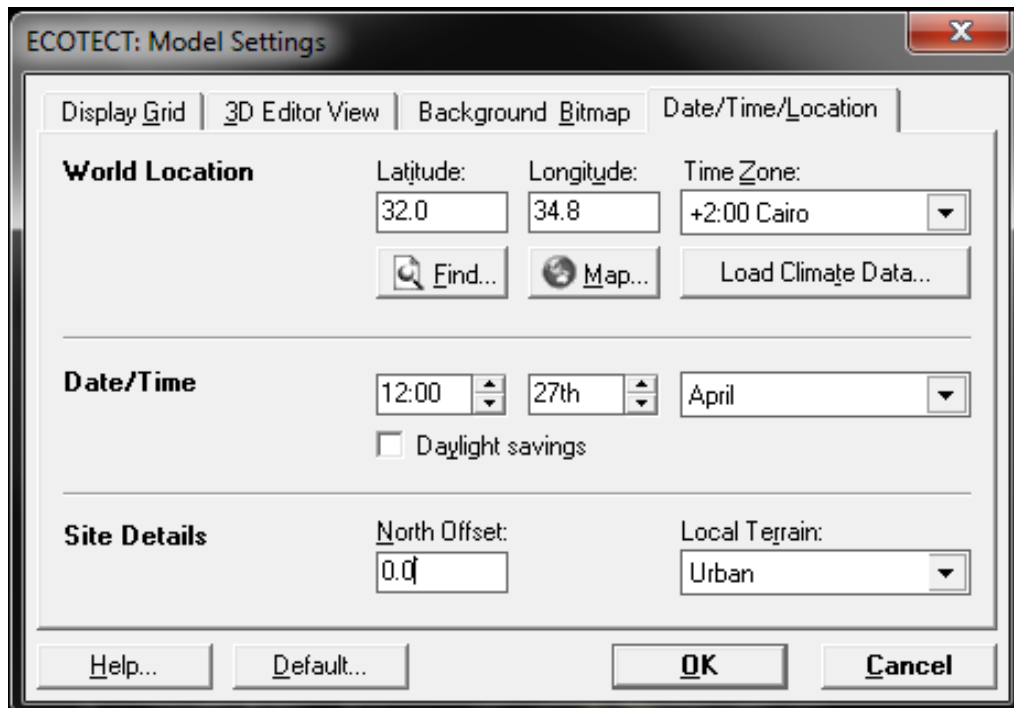

Figure (2): Location and Site Data in ECOTECT

Thermal properties for zones in ECOTECT

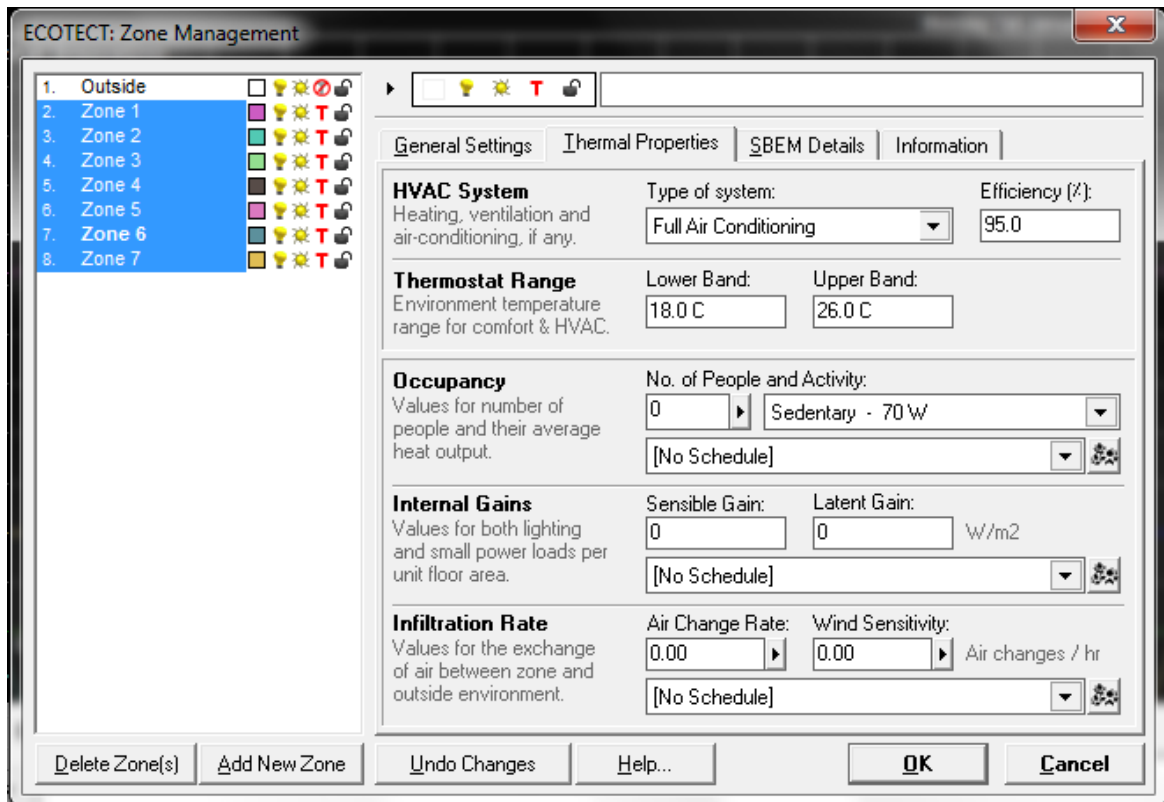

Figure (3): Thermal properties for zones in ECOTECT

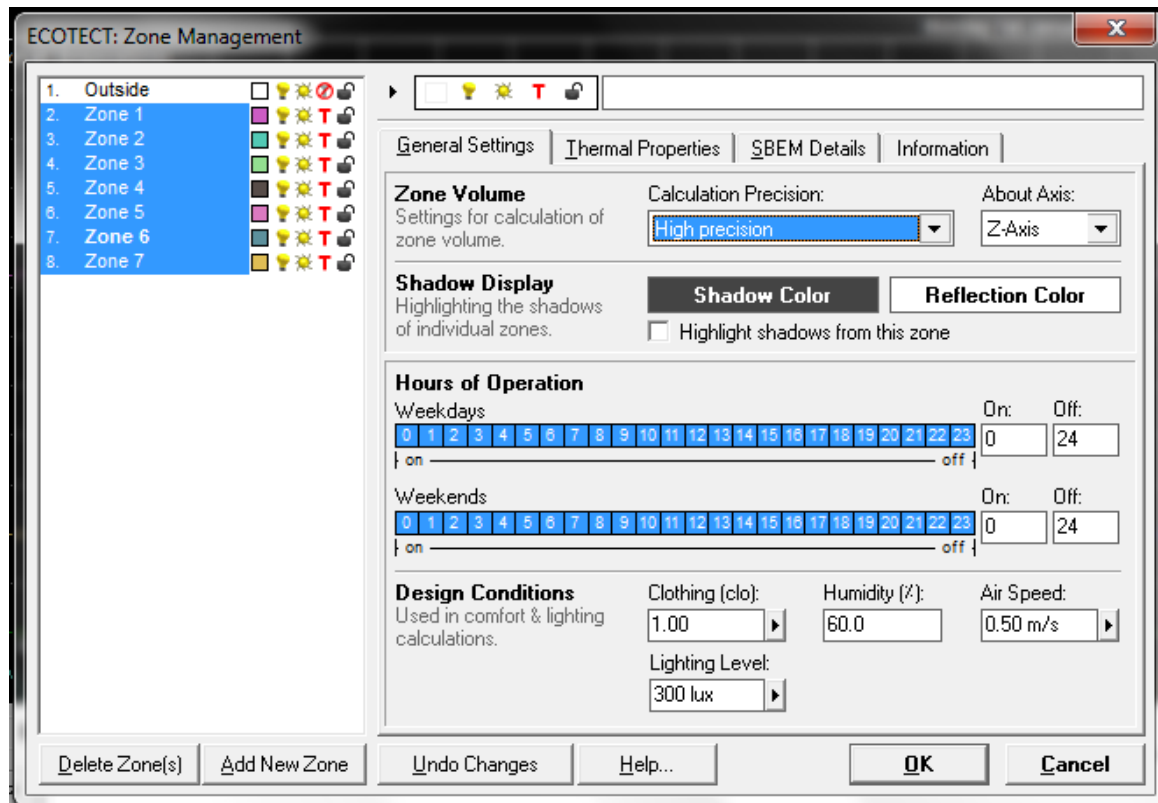

Figure (4): General Settings for Zones in ECOTECT

Materials Assignment in ECOTECT

Walls: ConcBlockPlaster1 with U-value= 2.25 W/m²*K and Thermal Lag= 7.36 hrs, see figures (5) and (6).

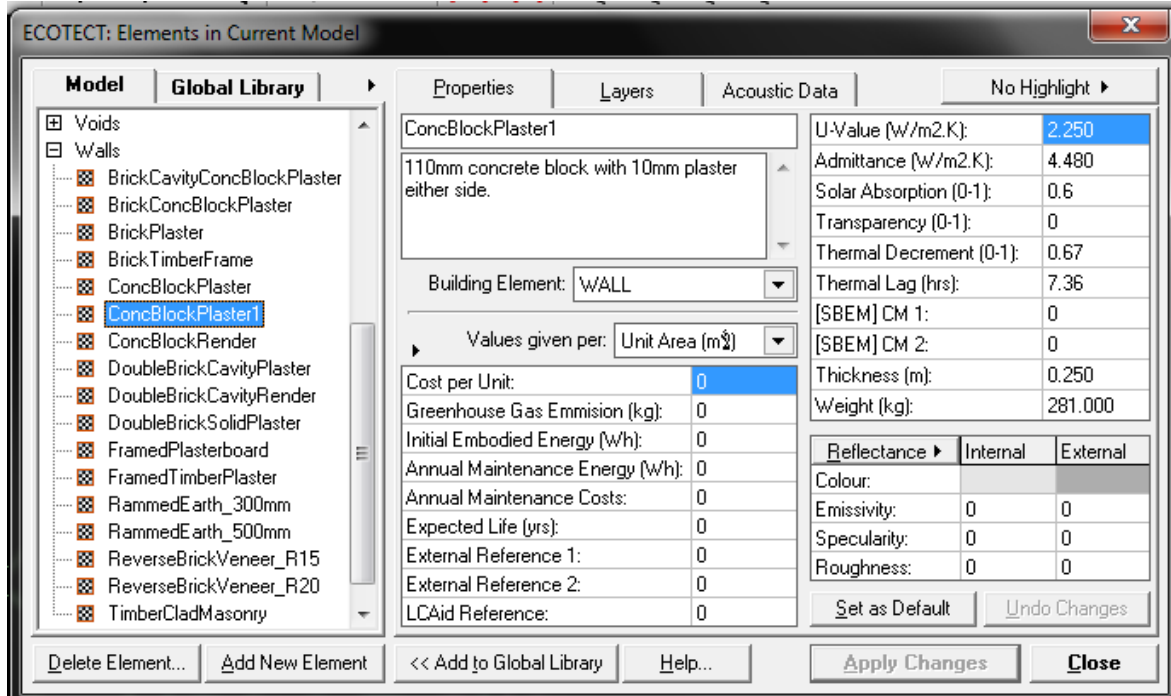

Figure (5): Properties of walls material in ECOTECT

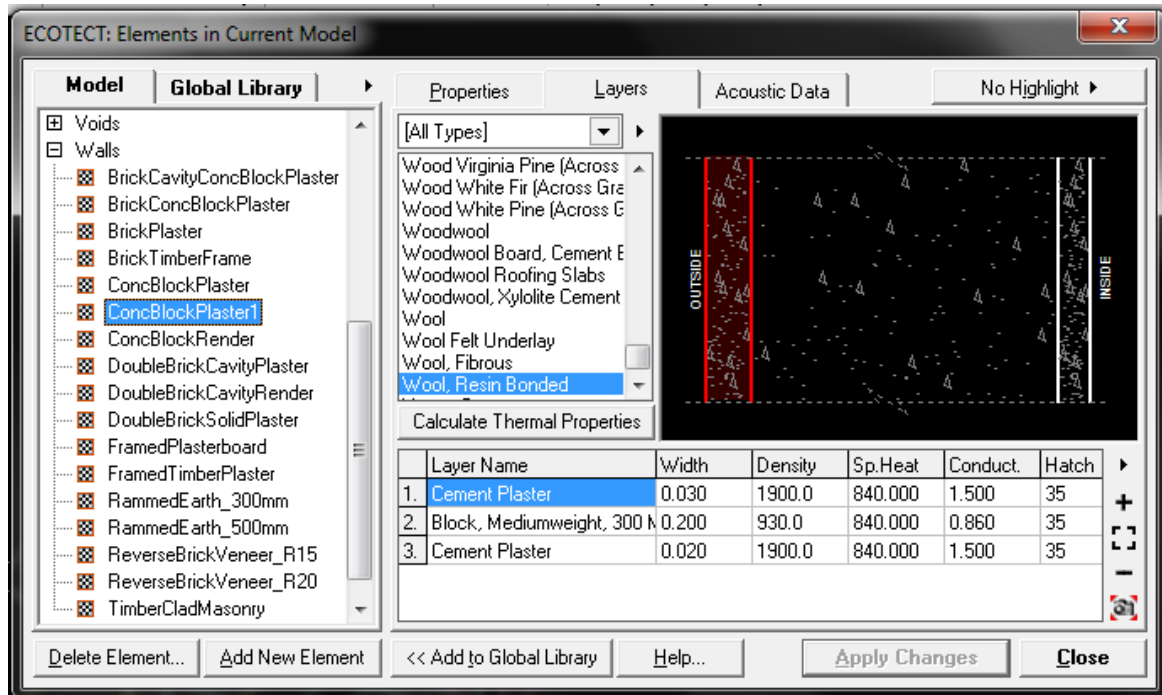

Figure (6): Layers of walls material in ECOTECT

Roof: ConcreteRoof_Aspphalt1 with U-value= 2.35 W/m²*K and Thermal Lag= 10.5 hrs, see figures (7) and figure (8).

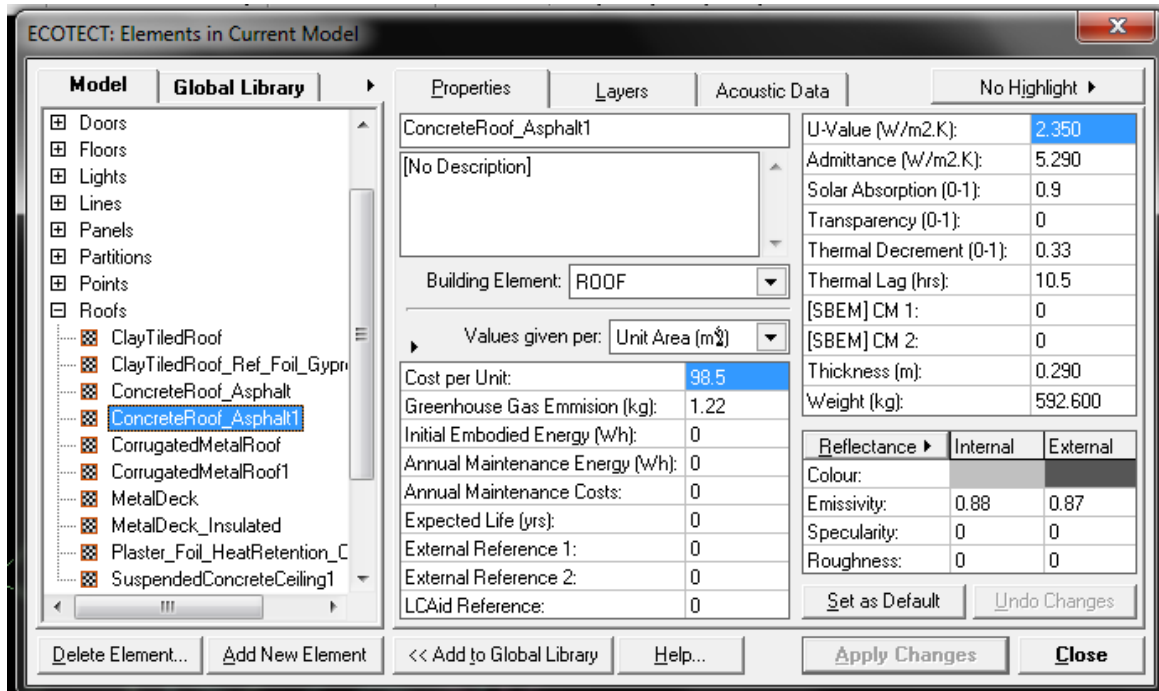

Figure (7): Properties of roof material in ECOTECT

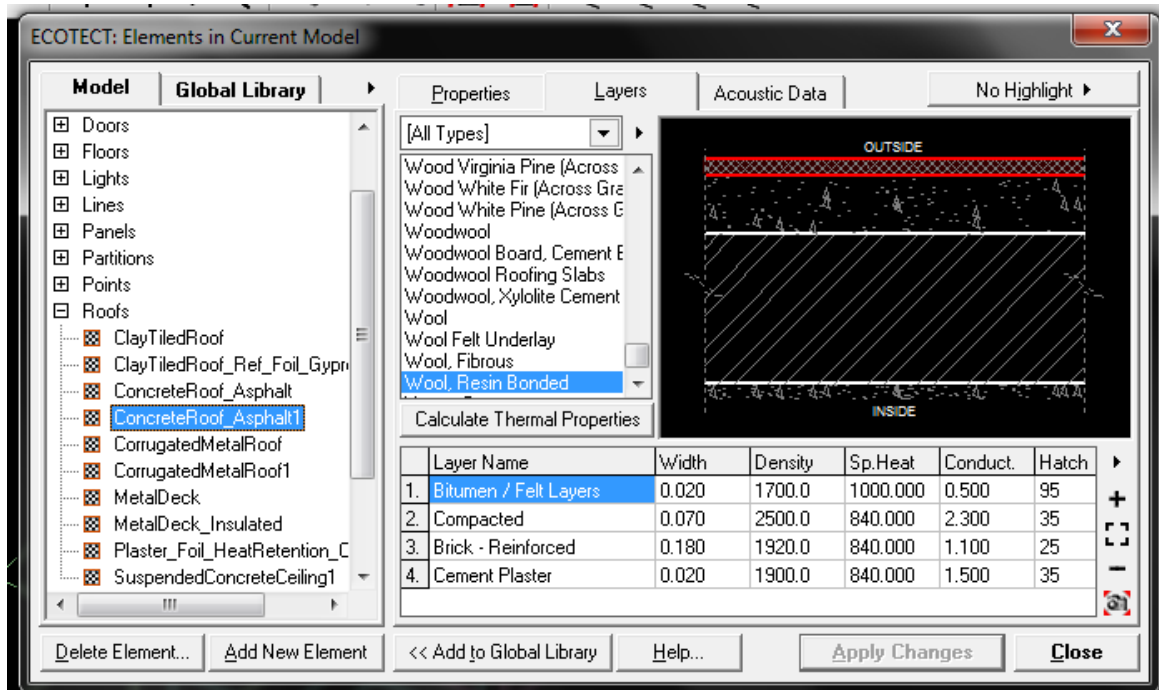

Figure (8): Layers of roof material in ECOTECT

Ceiling: ConcFlr_Carpeted_Suspended1_1 with U-value= 2.45 W/m²*K and Thermal Lag= 10.5 hrs, see figures (9) and figure (10).

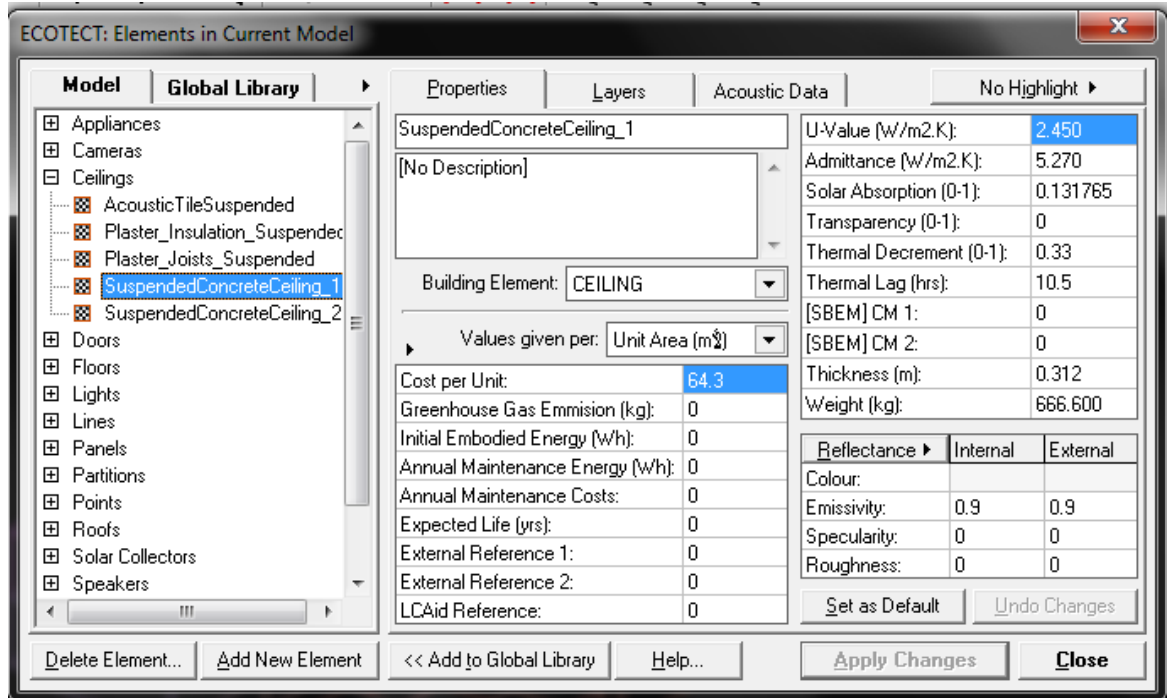

Figure (9): Properties of ceiling material in ECOTECT

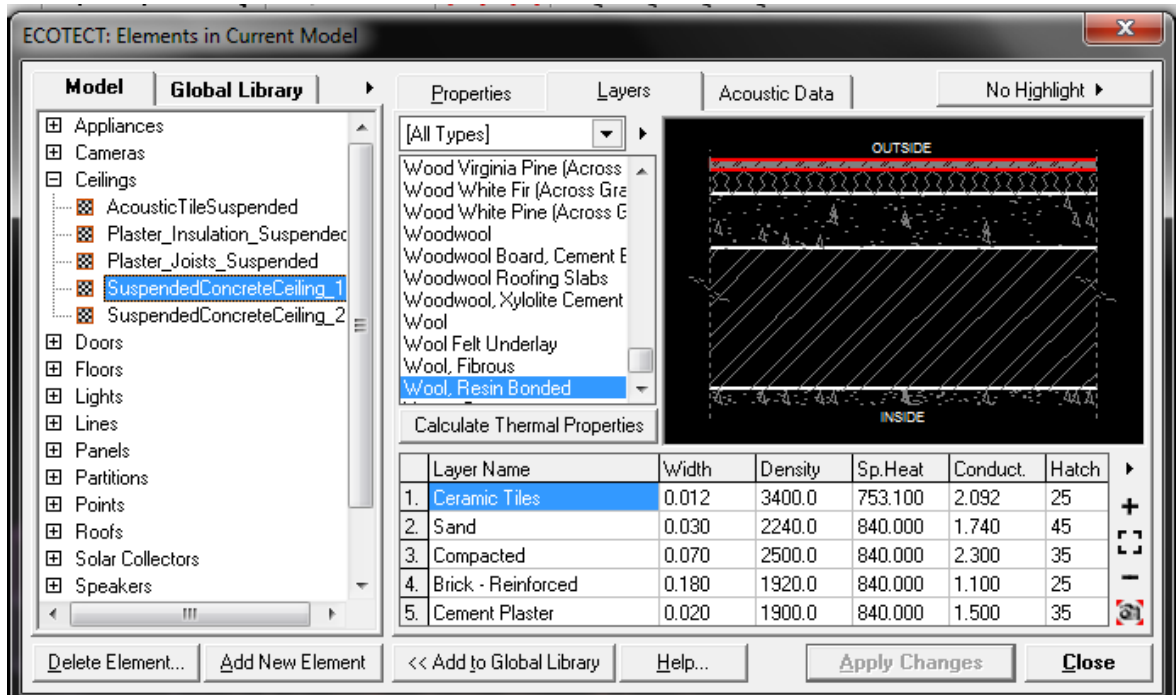

Figure (10): Layers of ceiling material in ECOTECT

Ground: ConcSlab_On Ground with U-value= 0.88 W/m²*K , see figures (11) and (12).

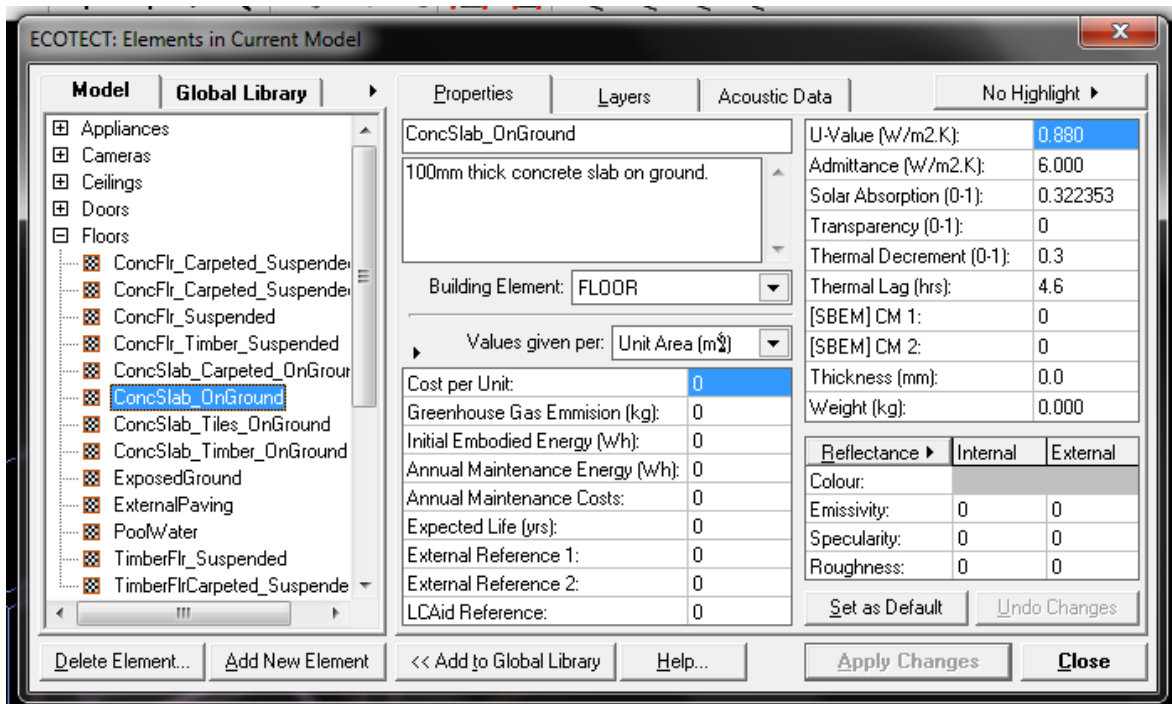

Figure (11): Properties of ground material in ECOTECT

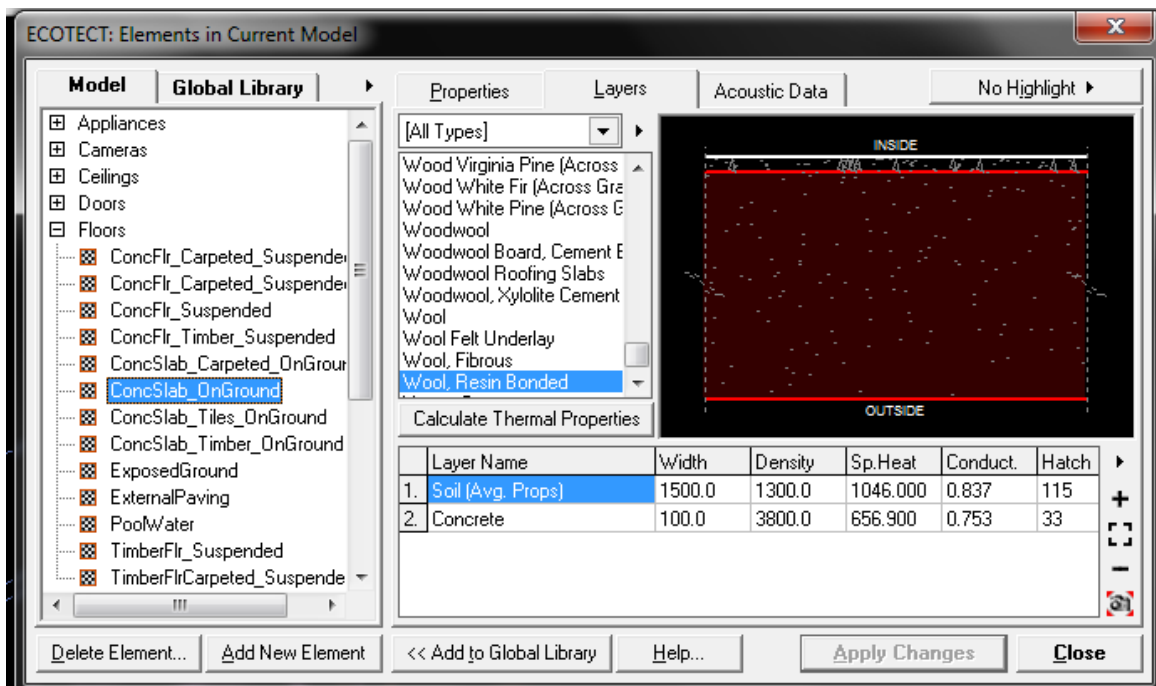

Figure (12): Layers of ground material in ECOTECT

Glass: Single Glazed with Aluminum Frame with U-value= 6 W/m²*K , see figures (13) and (14).

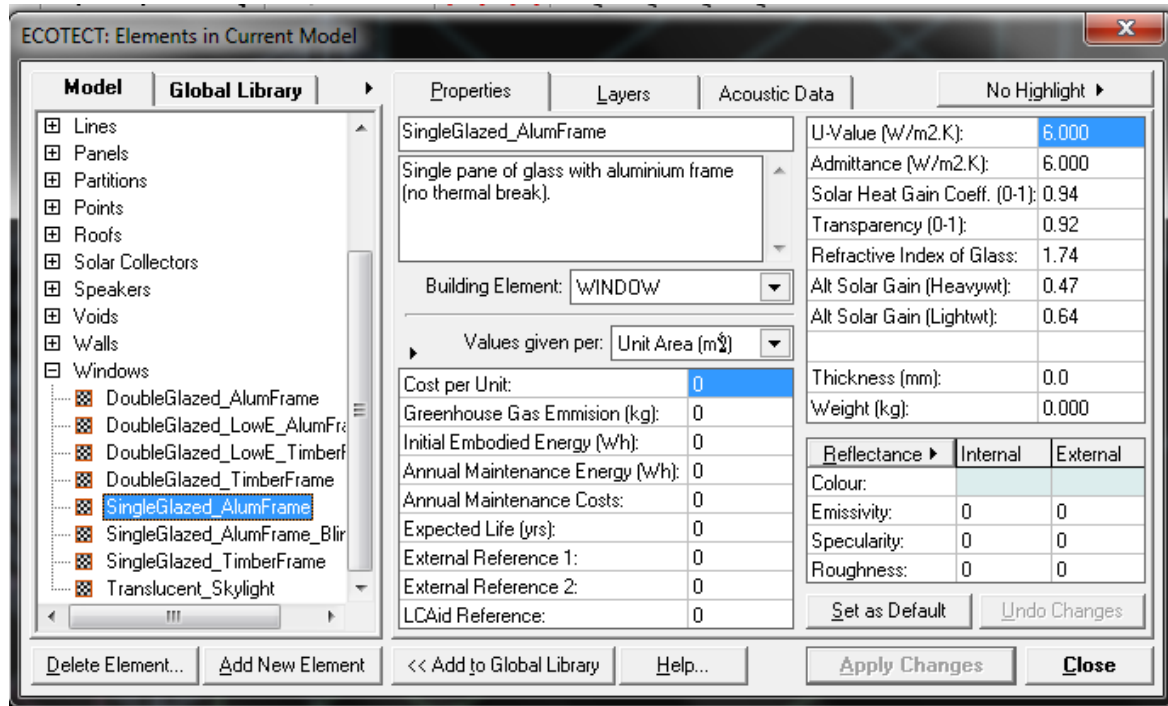

Figure (13): Properties of glass material in ECOTECT

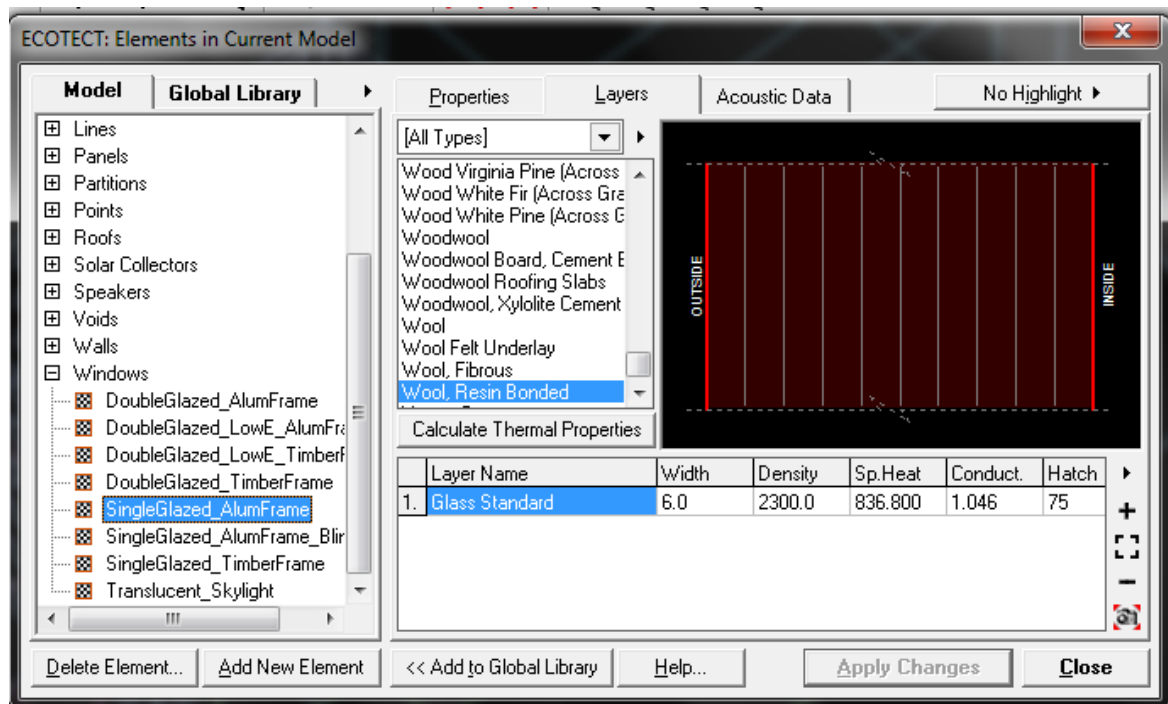

Figure (14): Layers of glass material in ECOTECT

IDA ICE Setting

The main window of the program, see figure (15).

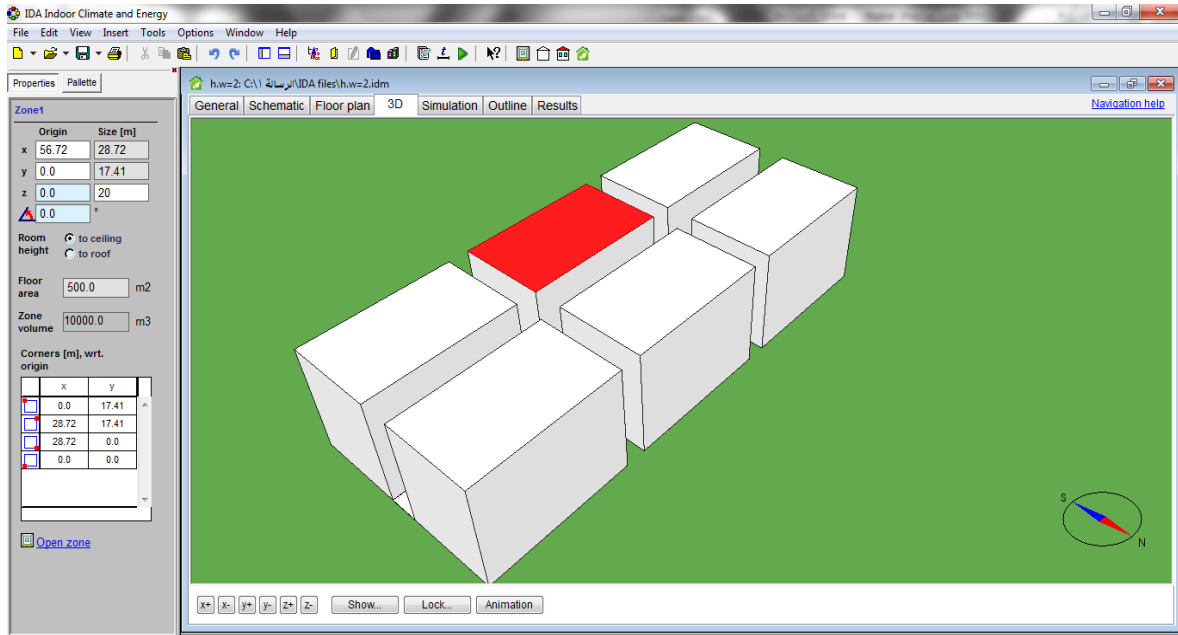

Figure (15): The main window of IDA ICE

Location and design weather data, see figure (16).

The screenshot shows two windows from the IDA ICE software. The left window is the 'Location' dialog box, which is used to define the project location and design weather data. The location is set to Tel Aviv-Yafo, Israel, with a latitude of 32.1 N and a longitude of 34.78 E. The design days are set for Winter (6.4 to 9.15 °C) and Summer (25.7 to 31.2 °C). The climate description is set to 'ISR_Tel Aviv-Bet Dagan.401790_MSI'. The right window is the 'Climate file' report, which displays a table of weather data for the period 15/07/2014 01:00 to 16/07/2014 00:00. The table includes columns for Hour, Dry-bulb temperature, Rel. humidity of air, Direct normal rad., Diffuse rad. on hor surf., WINDX, and WINDY.

Hour	Variables (averages for preceding hours)					
	Dry-bulb temperature, Deg-C	Rel. humidity of air, %	Direct normal rad., W/m2	Diffuse rad. on hor surf., W/m2	WINDX, m/s	WINDY, m/s
15/07/2014 01:00	22.4	94.5	0.0	0.0	0.5	2.8
15/07/2014 02:00	21.9	94.0	0.0	0.0	0.0	2.9
15/07/2014 03:00	21.7	94.0	0.0	0.0	0.0	3.1
15/07/2014 04:00	21.6	94.0	0.0	0.0	0.0	3.6
15/07/2014 05:00	21.6	94.0	0.0	0.0	0.0	4.1
15/07/2014 06:00	21.4	94.0	0.0	2.0	0.4	4.3
15/07/2014 07:00	21.4	94.0	34.5	18.5	0.1	3.8
15/07/2014 08:00	22.9	88.0	194.0	62.0	-0.3	3.6
15/07/2014 09:00	24.9	79.0	347.0	117.0	0.0	4.1
15/07/2014 10:00	27.2	68.5	379.0	162.5	0.4	4.3
15/07/2014 11:00	29.0	59.0	488.0	177.5	2.0	4.2
15/07/2014 12:00	29.8	56.5	585.5	181.0	4.3	3.5
15/07/2014 13:00	30.1	57.5	591.5	197.5	5.4	3.1
15/07/2014 14:00	29.8	58.5	657.5	195.0	5.4	3.1
15/07/2014 15:00	28.9	60.0	682.0	183.0	5.7	2.1
15/07/2014 16:00	28.4	62.0	616.0	181.5	6.4	1.1
15/07/2014 17:00	28.3	62.5	571.0	163.0	6.4	1.1
15/07/2014 18:00	28.0	64.0	508.5	116.5	5.6	0.1
15/07/2014 19:00	27.8	66.0	410.5	68.5	4.8	-0.4
15/07/2014 20:00	27.0	70.5	286.0	31.0	3.9	-0.9
15/07/2014 21:00	25.1	79.0	102.0	6.5	3.1	-1.2
15/07/2014 22:00	23.4	85.5	0.0	0.0	1.2	0.1
15/07/2014 23:00	22.8	88.5	0.0	0.0	-1.3	1.6
16/07/2014 00:00	22.3	90.5	0.0	0.0	-2.0	2.4
mean	25.3	77.3	268.9	77.6	2.2	2.3
mean*24.0 h	607.5	1854.0	6453.0	1863.0	52.0	56.4
min	21.4	56.5	0.0	0.0	-2.0	-1.2
max	30.1	94.5	682.0	197.5	6.4	4.3

Figure (16): Location and design weather data

Energy calculation (Heating load calculation and cooling load calculation), see figures (17) and (18).

The screenshot shows the 'Heating wizard' window. The title bar reads 'Heating wizard'. The main area is titled 'Heating load calculation'. On the left, there are three sections: 'Ventilation' with radio buttons for 'Fans off' and 'Fans according to their schedules, supply temperatures according to defined AHUs'; 'Internal gains' with input fields for 'Percentage of internal gains' (0) and 'Clothing (leave empty to keep clothing as defined in system)'; and 'Weather' with radio buttons for 'Use synthetic weather' and 'Design period using climate file'. The 'Design period using climate file' option is selected, with a dropdown menu showing 'ISR_Tel.Aviv-Bet.Dagan.401790_M'. To the right, there are 'Simulated period' and 'Simulated day' fields, both set to 'n.a.', and 'From' and 'To' date pickers set to '1 January' and '30 December' respectively. An 'Annotations' text area is on the right. At the bottom are 'Run' and 'Close' buttons.

Figure (17): Heating load calculation

The screenshot shows the 'Cooling wizard' window. The title bar reads 'Cooling wizard'. The main area is titled 'Cooling load calculation'. On the left, there are two sections: 'Internal gains' with input fields for 'Percentage of internal gains' (0) and 'Clothing (leave empty to keep clothing as defined in system)'; and 'Weather' with radio buttons for 'Use synthetic weather' and 'Design period using climate file'. The 'Design period using climate file' option is selected, with a dropdown menu showing 'ISR_Tel.Aviv-Bet.Dagan.4'. To the right, there are 'Simulated day' and 'Simulated period' fields, both set to 'n.a.', and 'From' and 'To' date pickers set to '1 January' and '30 December' respectively. An 'Annotations' text area is on the right. At the bottom are 'Run' and 'Close' buttons.

Figure (18): cooling load calculation

Elements of construction in IDA ICE

External wall: ConcBlockPlaster1, U-value= 2.24 W/m²*K, see figure (19).

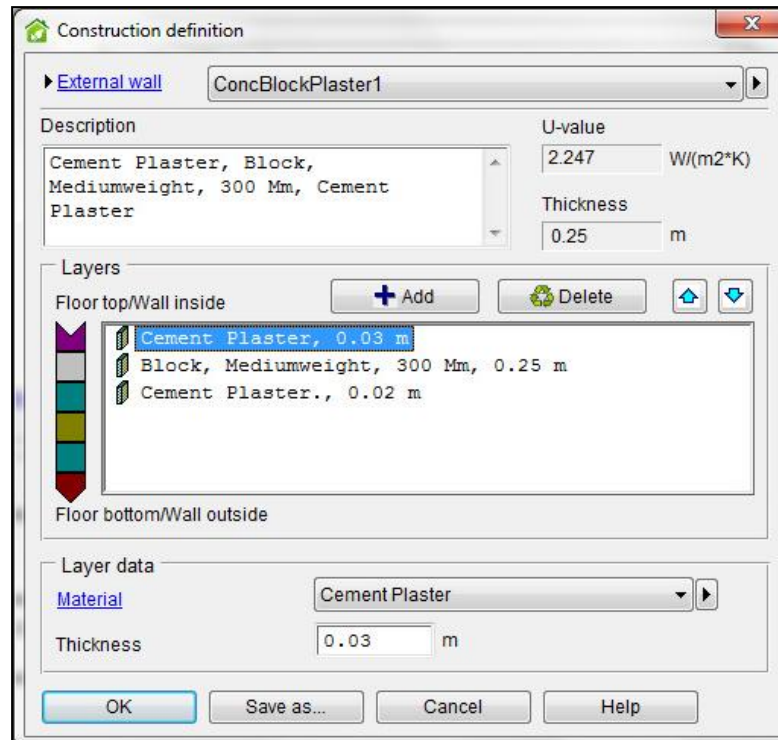

Figure (19): Layers of walls material in IDA ICE

Roof: ConcreteRoof_Aspphalt1 with U-value= 2.35 W/m²*K, see figure (20).

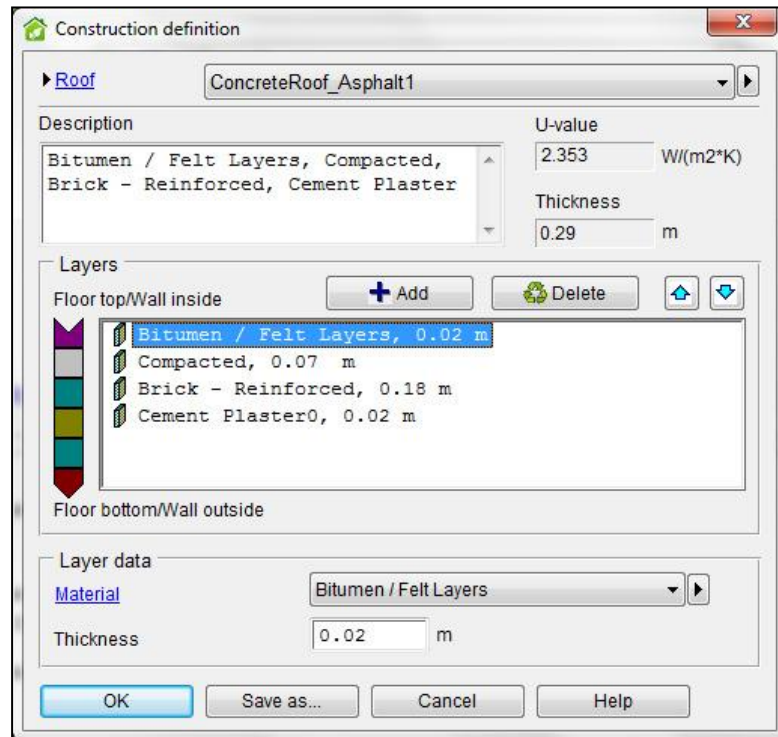

Figure (20): Layers of roof material in IDA ICE

Ground: ConcSlab_On Ground with U-value= 0.813 W/m²*K , see figure (21).

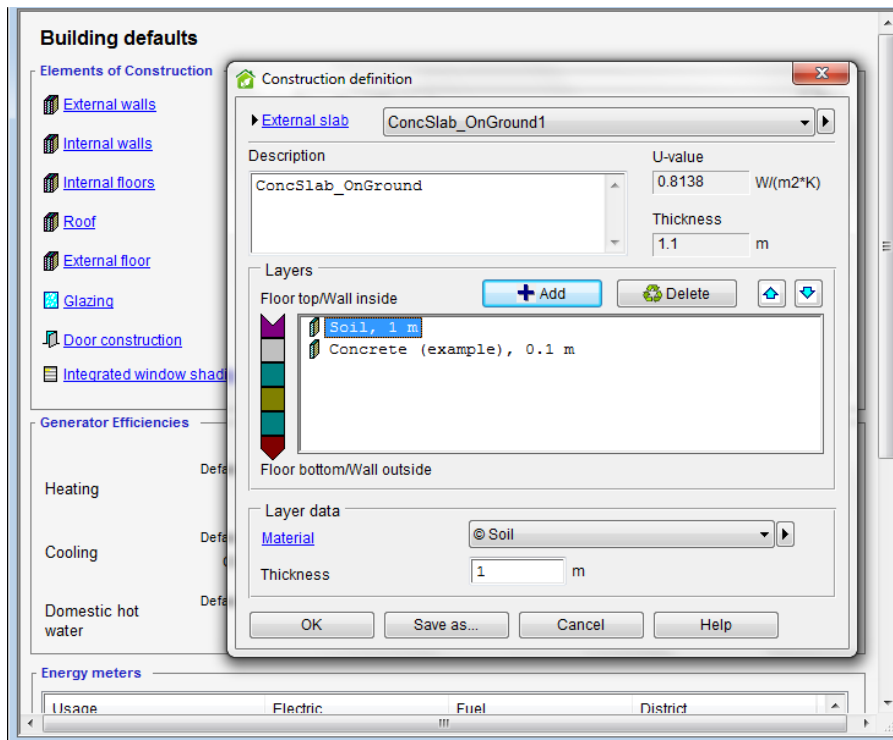

Figure (21): Layers of ground material in IDA ICE

Glass: Single Glazed with Aluminum Frame with U-value= 5.8 W/m²*K , see figure (20).

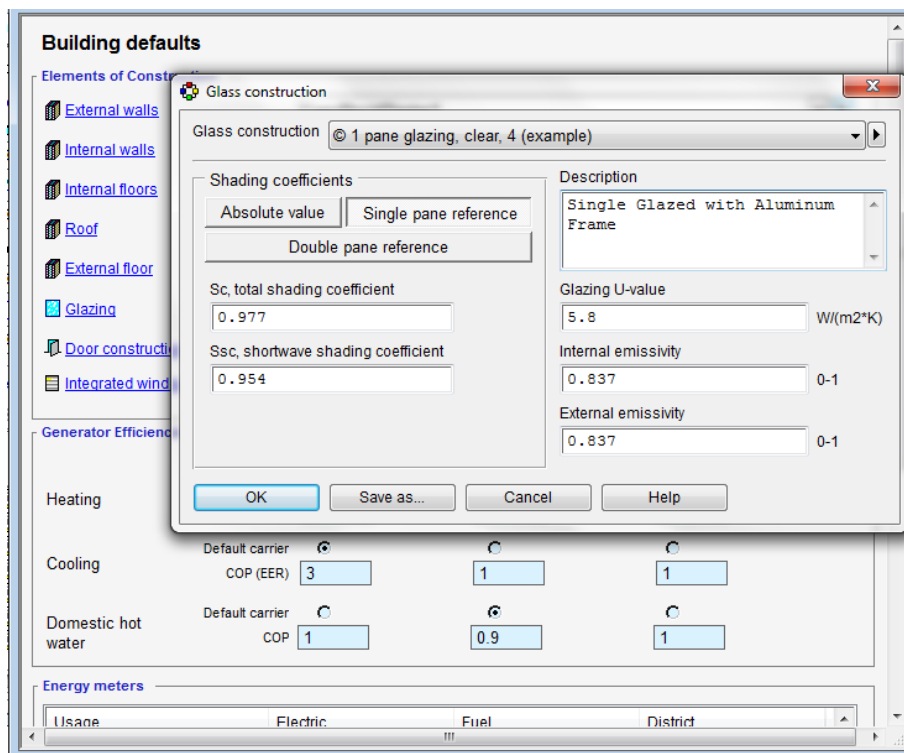

Figure (22): Layers of glass material in IDA ICE



الجامعة الإسلامية- غزة
عمادة الدراسات العليا
كلية الهندسة
قسم الهندسة المعمارية
برنامج ماجستير الهندسة المعمارية

أثر تشكيل الشوارع على الأداء الحراري للمباني في قطاع غزة

إعداد

نضال رسمي إسماعيل أبو مصطفى

إشراف

د.م. أحمد سلامة محيسن

قدمت هذه الأطروحة استكمالاً لمتطلبات الحصول على درجة الماجستير في الهندسة المعمارية من كلية الدراسات العليا في الجامعة الإسلامية في غزة، فلسطين.

1436هـ - 2015 م